

**Gremlin/SEGA<sup>®</sup>**

# **MOON CRESTA**

**Service Manual & Parts Catalog**

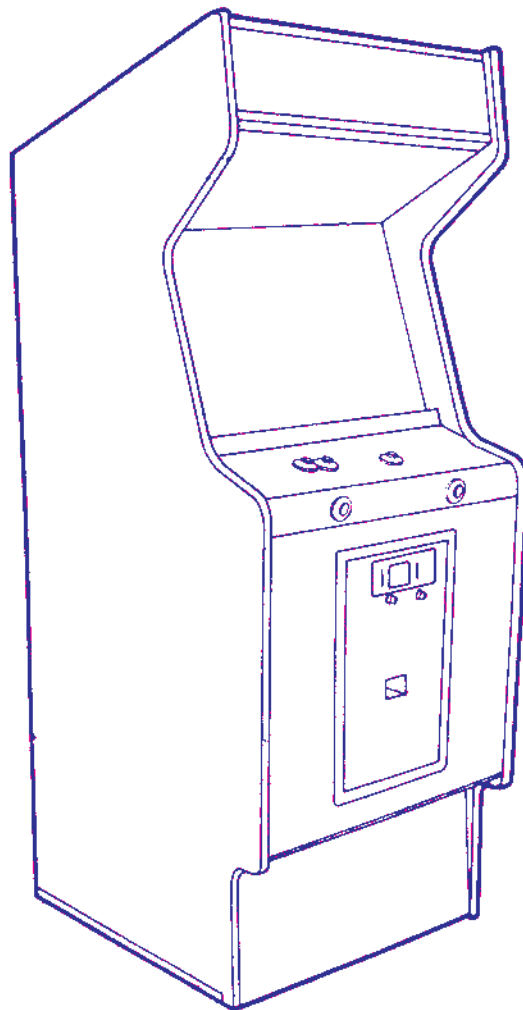

**GREMLIN INDUSTRIES, INC.**

## CONTENTS

1. Installation	-----	2
2. Care in Operation	-----	2
3. Game Play	-----	3
4. IC Board Adjustments	-----	4
5. TV Volume Adjustments (1)	-----	5
TV Volume Adjustments (2)	-----	6
Adjustable Controls	-----	7
6. Color Monitor Troubleshooting	-----	8
7. Parts Catalog	-----	9~18
8. Schematics	-----	Following Pages

## SPECIFICATIONS

* Space Requirer	-----	638 mm x 703 mm
* Game Height	-----	1722 mm
* Power Source	-----	AC 100V~240V
* CRT	-----	20 Color TV
* Power Consumption	-----	120 W

Note : These instructions and specifications may be changed without prior notification. If this machine is reconstructed without our permission, we can not take responsibility for the machine.

# 1 INSTALLATION

1. As the SEGA Monaco GP is for "indoor use", do not install outdoors.
2. When installing, avoid the following places.
  - Near indoor pools or showers
  - Where leaks exist
  - Under direct sunlight
  - Near heaters or other heat emitting devices
  - Where hazardous items (volatile fluids, gas cylinders etc.)
  - Where vibrations are severe (near construction sites where jack hammers etc. are used)
  - Inclined places
  - Near fire extinguishing equipment
  - Near emergency exits
  - Set power transformer changeover switch to 110V in locations where the power is normally below 90V.

# 2 CARE IN OPERATION

1. Inspection
  - Are the IC boards and other connectors firmly connected.
  - Connect ground wire as prescribed. (Never connect to gas pipes, water pipes or electrical conduits)
  - Arrange line cords and ground wires in the aisle so they will not be tripped over.
2. Care in Handling
  - Always turn off the power supply switch before handling.
  - Avoid inserting and pulling the plug in rapid succession.
  - Do not check the IC board circuit with a tester.
3. Care in Usage
  - Care should be taken to avoid dragging or dropping the machine when transporting to prevent damage to the CRT.
  - Use fuse of stipulated rating.
  - As high voltage is present in the monitor and TV PCB, adjustments or repairs should be left up to a serviceman and should never be touched by the layman.
  - As color alignment may become disturbed due to terrestrial magnetism when the machine is moved or its direction changed, demagnetize the unit by pushing the demagnetizing switch.
  - Refrain from holding the steering wheel or shift lever when transporting the machine.

### 3 Game Play

Gremlin/Sega "MOON CRESTA" is a one or two player game in which players may compete for highest score against the game computer. Each time a player is hit by an alien, the game switches to his opponent's sequence.

The object is to destroy as many of the descending aliens as possible. To accomplish this the player is given a three stage multi-fire Warship. He begins with the first stage, firing a single laser at the enemy. If he is successful in eliminating the first four sets of aliens, he is given an opportunity to dock his first stage onto the second within a specific time limit (the sooner he unites the stages, the higher is his awarded score).

Once docked, the stages combine their firing power, so the first (one laser) adds to the second (two lasers) giving the player a total of three usable lasers as the game continues.

The player then must face two more sets of aliens and a shower of meteors, after which he has a chance to dock again, this time uniting with the third stage for a combined fire power of five lasers. If he is able to defeat the last two sets of aliens intact, the entire sequence begins again. The game continues with increasing difficulty until the entire warship is destroyed. When the warship is hit the player continues with whatever stages remain. If his score reaches 30,000 he is awarded a free game and his score continues to accumulate.

# 4 IC Board Adjustments

- Note :
- Switch adjustment have to be done after disconnect the power supply.
  - Switches are set as under-lined position when the machine is shipped.

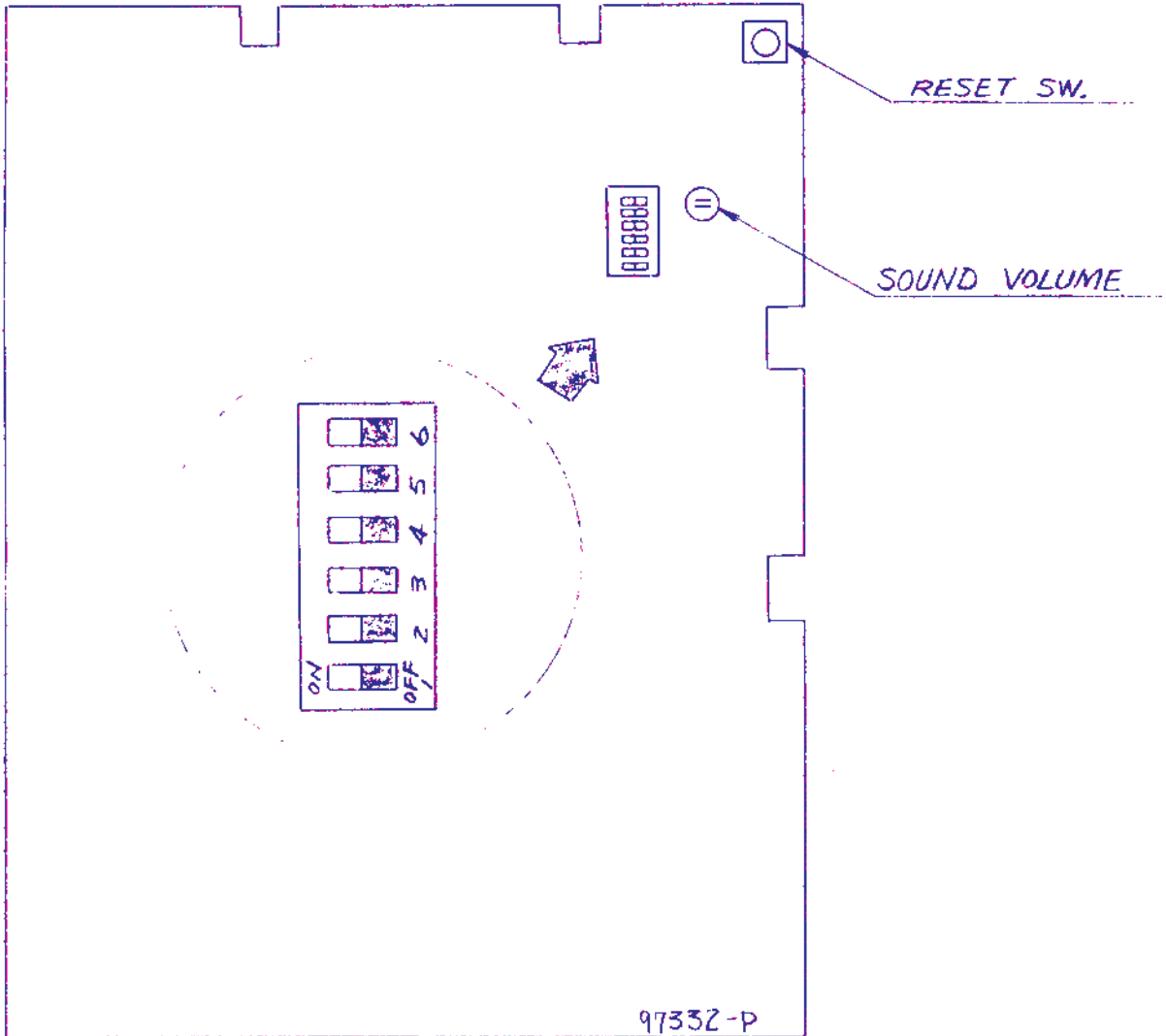

	SW. NO.					
	1	2	3	4	5	6
EXTENDED PLAY						
30000 PT.	<u>OFF</u>					
50000 PT.	<u>ON</u>					
	NOT USE					
COIN CHUTE 1						
1 COIN - 1 PLAY			<u>OFF</u>	<u>OFF</u>		
2 COIN - 1 PLAY			<u>ON</u>	<u>OFF</u>		
3 COIN - 1 PLAY			<u>OFF</u>	<u>ON</u>		
4 COIN - 1 PLAY			<u>ON</u>	<u>ON</u>		
COIN CHUTE 2						
1 COIN - 1 PLAY					<u>OFF</u>	<u>OFF</u>
1 COIN - 2 PLAY					<u>ON</u>	<u>OFF</u>
1 COIN - 3 PLAY					<u>OFF</u>	<u>ON</u>
FREE PLAY					<u>ON</u>	<u>ON</u>

5. TV VOLUME ADJUSTMENTS (1)  
(NANAQ TYPE)

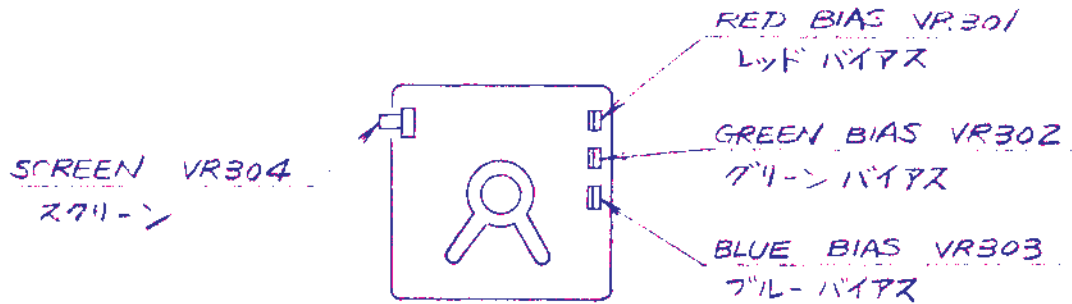

BRIGHT VR104  
輝度

V-HOLD VR401 垂直同期

H-HOLD VR501 水平同期

V-POS. VR402 垂直位置

H-POS. VR502 水平位置

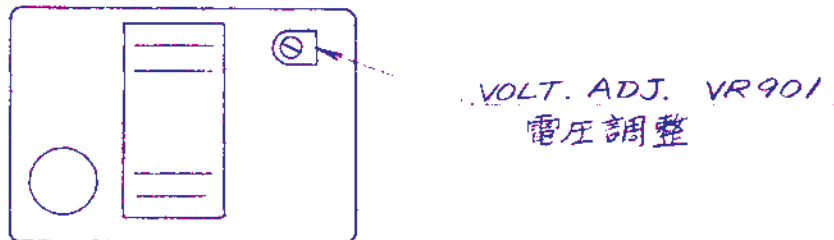
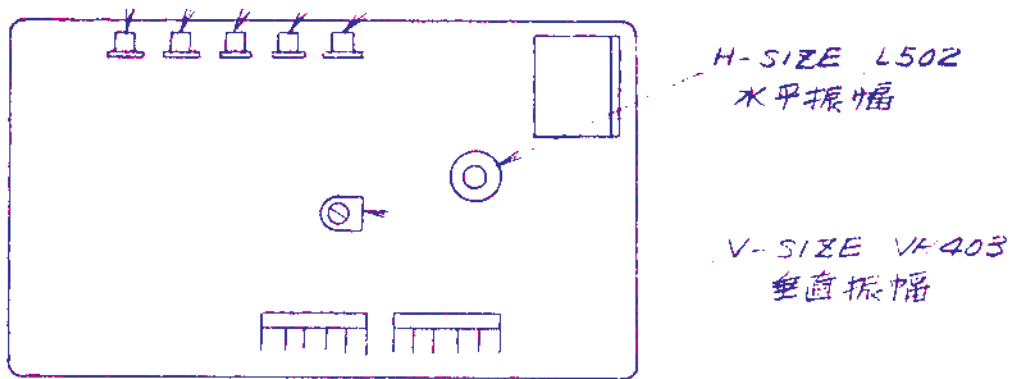

5 TV VOLUME ADJUSTMENTS (2)  
(SHARP TYPE)

BLUE DRIVE R866  
ブルドライブ

GREEN DRIVE R859  
グリーンドライブ

SIZE COIL L602  
水平振幅

RED BIAS R854  
レッドバイアス

GREEN BIAS R861  
グリーンバイアス

BLUE BIAS R868  
ブルバイアス

SCREEN R872  
スクリーン

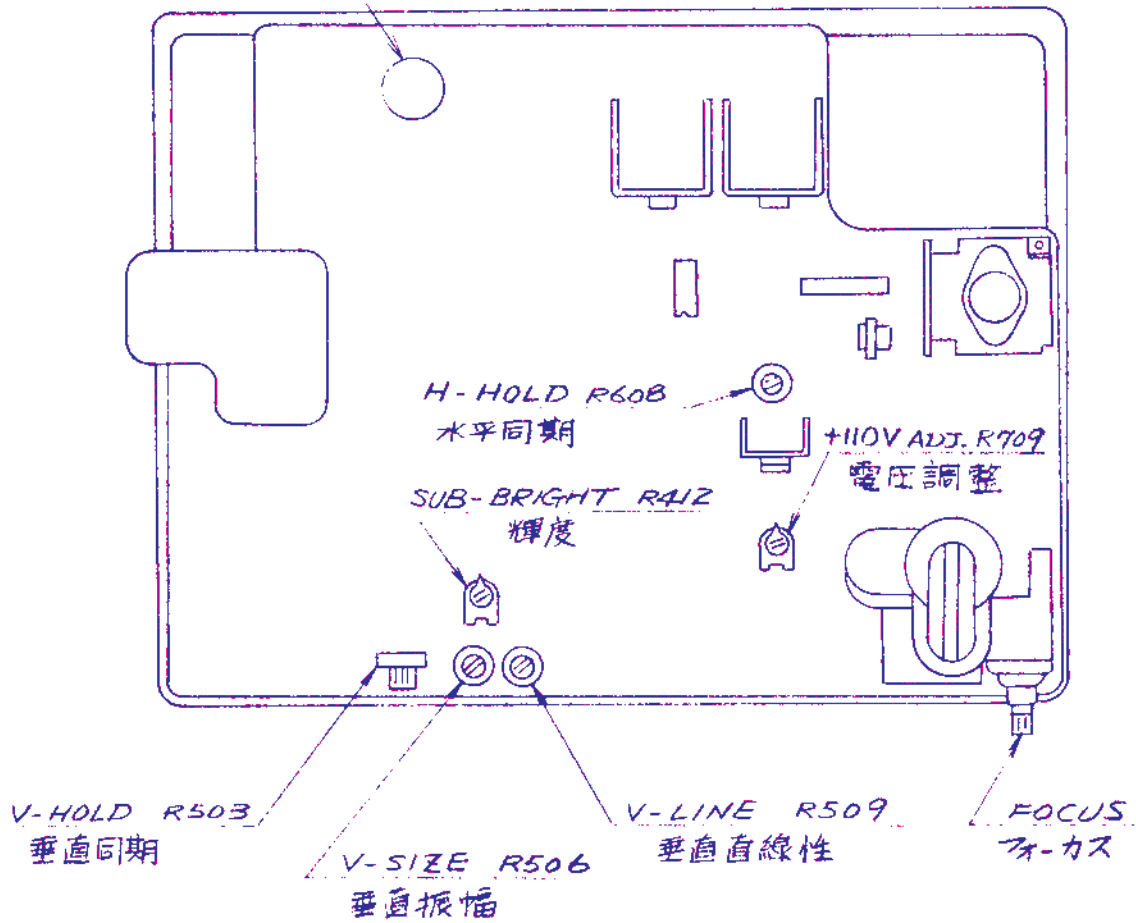

# 5 Adjustable Controls

## A. Brightness

**Remember to observe the precautions regarding high voltages when you make any adjustments on this monitor!**

Note that before you adjust the brightness, the monitor should have been turned on for at least 5 minutes. Keep the game in the attract or play mode.

Find the black plastic knob near the top center of the Neck Printed-Circuit Board or PCB, sometimes called the picture-tube socket board (see Figure 2). Turn this brightness (or screen voltage) control until you achieve a pleasing level of brightness.

Too high a brightness causes the retrace lines to show. Too low a brightness causes the entire screen to become dark and obscured.

## B. Horizontal Hold

Use this adjustment if the picture drifts sideways across the screen. Find the two potentiometers on the right end of the Main PCB (as you face the monitor's screen)—see Figure 3. Turn the coarse or fine pot until the black lines no longer slant downwards or upwards, and you obtain a normal screen image.

## C. Vertical Hold

Use this adjustment if the picture drifts straight up or down on the screen. The vertical hold control is the large black knob, third from the left on the Main PCB (as you face the monitor's screen)—see Figure 3.

Turn this control in either direction until the picture no longer drifts straight up or down on screen.

## D. Vertical Linearity

Badly adjusted vertical linearity looks like the horizontal raster lines are "squashed" together in certain areas on the screen—usually at the top or bottom. Linearity tends to drift out of adjustment in high-temperature areas after the monitor has been used a long time, or if you replace the picture tube.

Turn this control in either direction until the picture no longer disappears off the edges, which would indicate overscanning.

The vertical linearity control is located on the Main PCB, fourth from the left as you face the monitor screen. Turn it slowly until all the raster lines are about equally spaced vertically.

## F. Horizontal Width

Before using this control, be sure the monitor has been turned on for 5 minutes or more. If the screen image is too wide or narrow, you should use this control to adjust it for proper width.

## E. Vertical Height

If the screen image is not large enough or too large vertically, then you can adjust it very easily with this control. Using this control will stretch or compress the image vertically. The vertical height control affects the spacing between the raster lines equally.

Set the game for the diagnostic that displays the convergence grid and dots. Locate the horizontal width control on the monitor's Main PCB: it is the small coil at the center rear of this board. **Be sure to use only a non-metal Allen wrench (commonly called a "tweaking" tool) for this adjustment!** Turn this control until the right and left grid lines run along the edges of the screen. The lines should not disappear off the edges, which would indicate overscanning.

## G. Focus

Set the game for the diagnostic that displays the convergence grid and dots. Locate the vertical height control on the monitor's Main PCB: it is the second knob from the left underneath the screen. Turn this control until the top and bottom grid lines run along the edges of the screen. The lines should

This control simply changes the sharpness of the screen image. The focus adjustment is above the right rear of the monitor's Main PCB; the black adjustment knob protrudes from the high-voltage housing/heat sink. Turn this control until you get the optimum screen sharpness possible.



# Color Monitor Troubleshooting

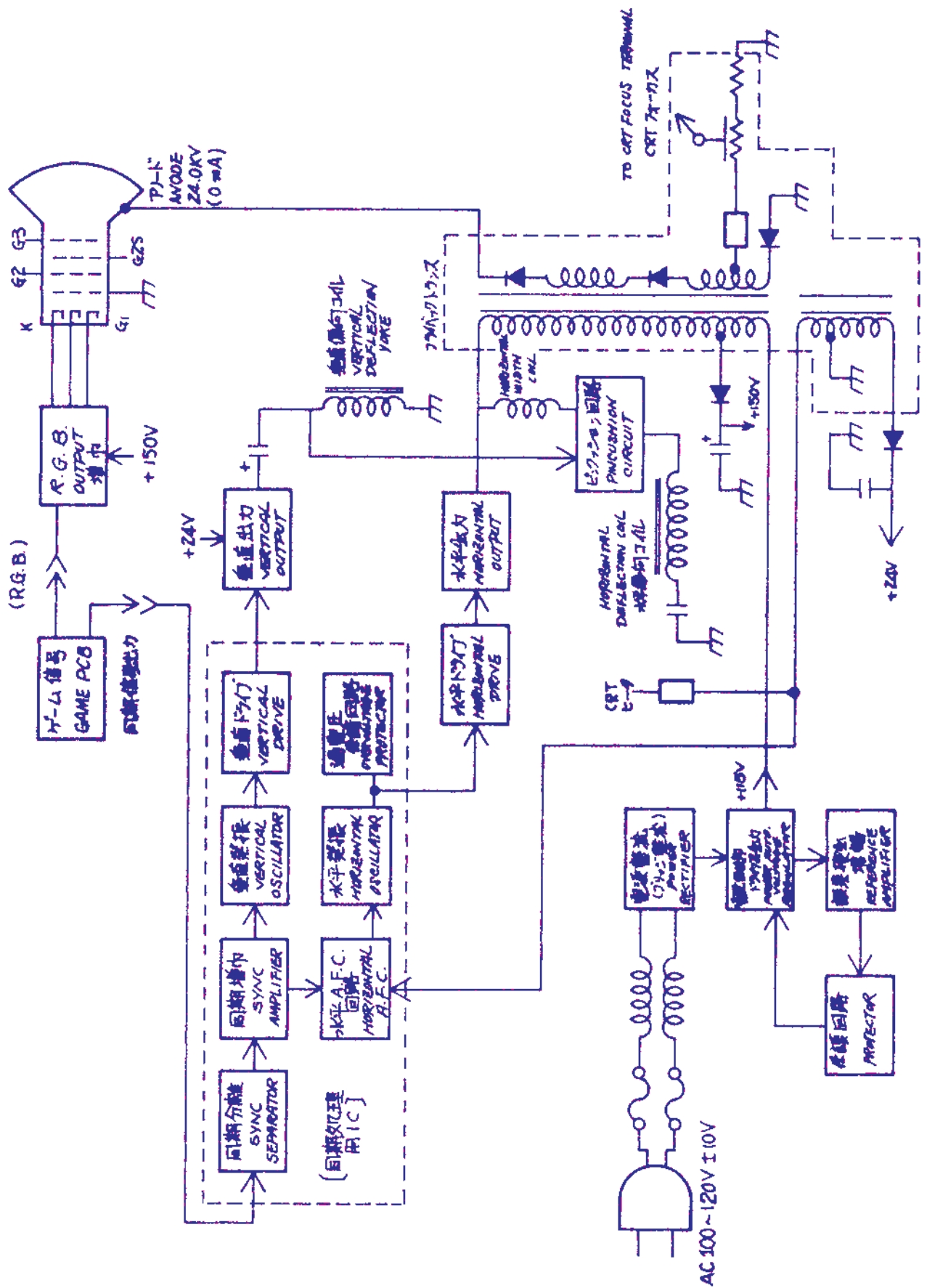

# 7 Parts Catalog

## Cabinet Accessory Assy

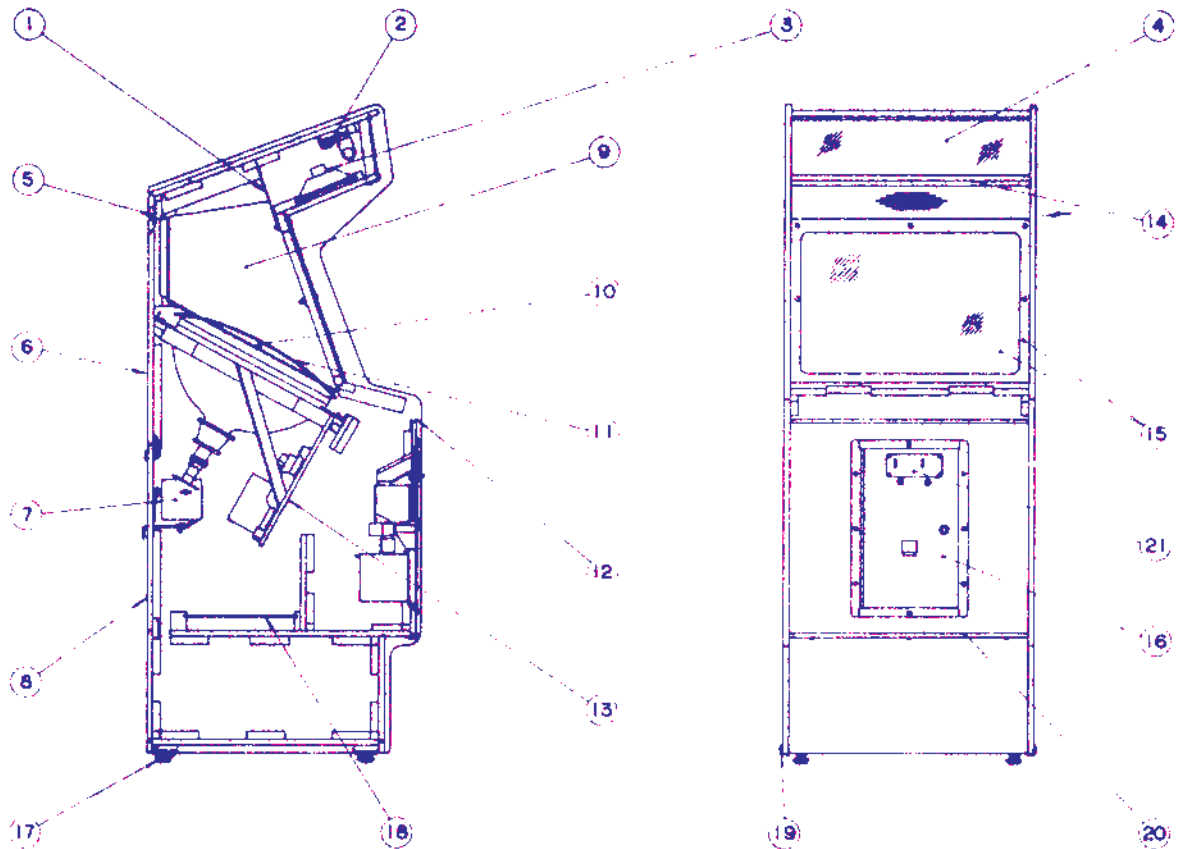

- |    |            |                                   |
|----|------------|-----------------------------------|
| 1  | MK-1015    | Light Baffle                      |
| 2  | MK-1004    | FLUORESCENT LIGHT ASSY,15W        |
|    | S-91058    | Fluorescent Light,Black Light,15W |
| 3  | MR-1009    | Speaker Guard Plate               |
|    | S-97336    | Speaker,230 x 150mm,8Ω,6W         |
| 4  | MR-1012    | Top Panel                         |
| 5  | MO-1071    | Net Plate                         |
| 6  | MK-1002    | Back Door,Upper                   |
| 7  | MR-1019    | JUNCTION BOX ASSY                 |
|    | 97339      | Choke,1μH                         |
|    | S-94972    | Noise Filter,AC250V,2A            |
|    | S-94339    | Switch,Micro Type                 |
|    | S-95835    | Cable & Plug Assy                 |
|    | S-96774    | Fuse,5A,Time-Lag Type             |
| 8  | MR-1003    | Back Door,Lower                   |
| 9  | MK-1017    | Scenery,right                     |
|    | MR-1018    | Scenery,Left                      |
| 10 | MR-1016    | Scenery,Rear                      |
| 11 | MR-1024    | TV Mask                           |
| 12 | MK-1005    | Trim,Upper                        |
| 13 | 97232-P    | COLOR DISPLAY ASSY,20TYPE,120V    |
|    | 97334-P    | COLOR DISPLAY ASSY,20TYPE,100V    |
| 14 | MR-1007    | Ornament Frame                    |
| 15 | MR-1013    | Window Panel                      |
|    | MR-1014    | Bezel Frame                       |
| 16 | MR-1200    | COIN CHUTE DOOR & CASH BOX ASSY   |
|    | CC-2006    | Coin Chute,Rejector Type,25¢ x 1  |
| 17 | M-163-4(L) | Leg Adjuster                      |
| 18 | 97332-P    | IC BOARD ASSY,MOON CRESTA         |
| 19 | MR-1008    | Corner Protector                  |
| 20 | MR-1006    | Trim,Lower                        |
| 21 | 80824      | Denomination Plate,25¢            |
|    | MO-1245    | Coin Entry Plate,USA 25¢ x 2      |

# 7 Parts Catalog

## Control Panel Assy

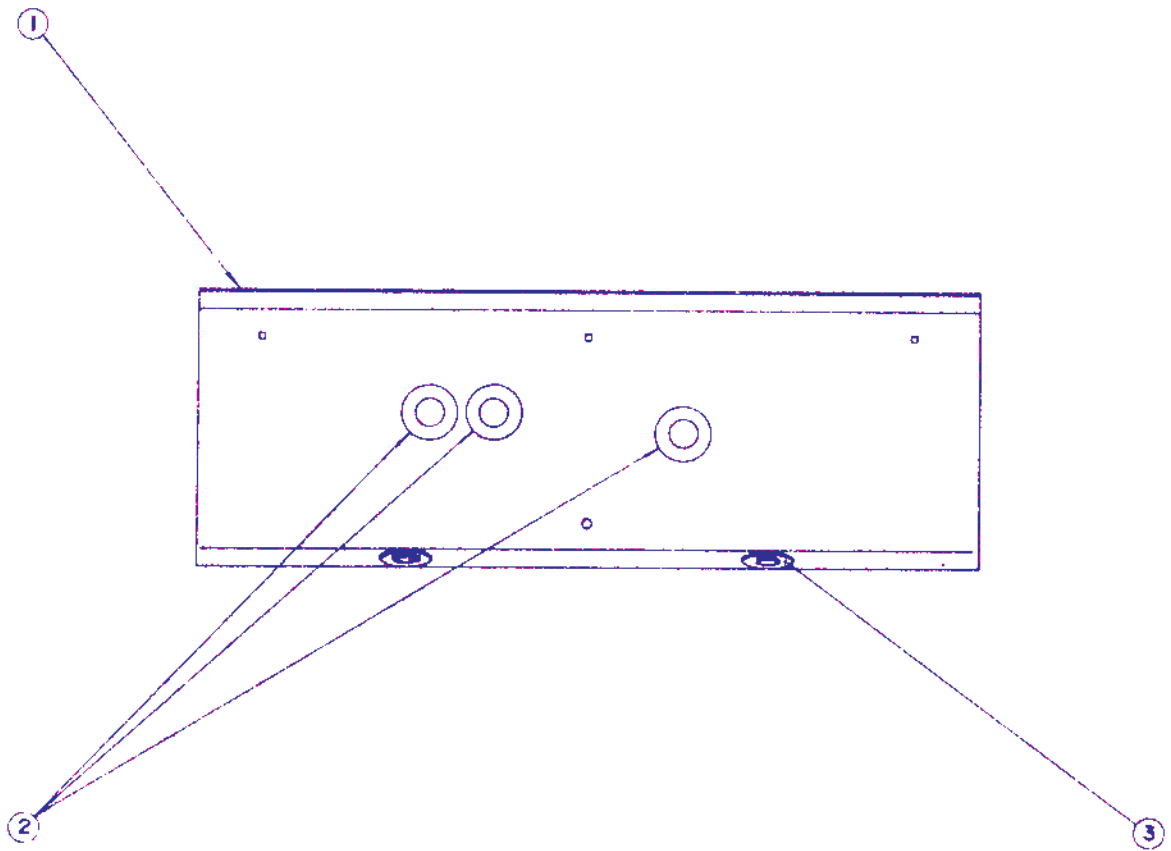

- |   |         |   |
|---|---------|---|
| 1 | MR-2001 | Control Panel Base                        |
| 2 | MR-2005 | Spacer, Switch Wico                       |
|   | S-97345 | Button Plunger, Yellow (GREMLIN 240-0009) |
|   | S-97346 | Assy, Switch Wico (GREMLIN 510-0023)      |
| 3 | MR-2005 | Spacer, Switch Wico                       |
|   | S-97344 | Button Plunger, Black (GREMLIN 240-0007)  |
|   | S-97346 | Assy, Switch Wico (GREMLIN 510-0023)      |

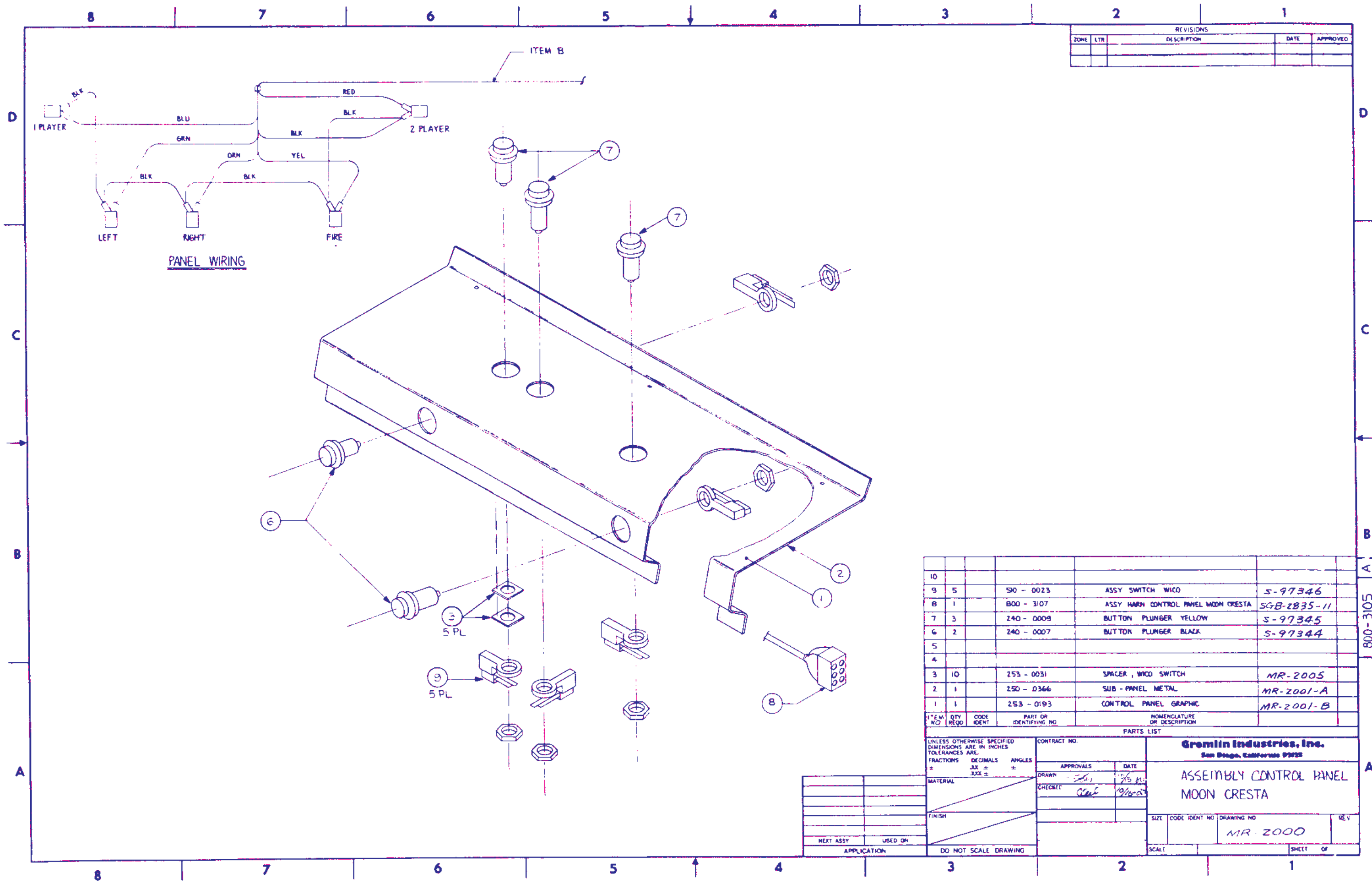

REVISIONS				
ZONE	LTR	DESCRIPTION	DATE	APPROVED

ITEM NO	QTY REQD	CODE IDENT	PART OR IDENTIFYING NO	NOMENCLATURE OR DESCRIPTION	
10					
9	5		50 - 0023	ASSY SWITCH WICO	S-97346
8	1		800 - 3107	ASSY WARN CONTROL PANEL MOON CRESTA	800-3105-11
7	3		240 - 0008	BUTTON PLINGER YELLOW	S-97345
6	2		240 - 0007	BUTTON PLINGER BLACK	S-97344
5					
4					
3	10		253 - 0031	SPACER, WICO SWITCH	MR-2005
2	1		250 - 0366	SUB - PANEL METAL	MR-2001-A
1	1		253 - 0193	CONTROL PANEL GRAPHIC	MR-2001-B

UNLESS OTHERWISE SPECIFIED DIMENSIONS ARE IN INCHES TOLERANCES ARE:

FRACTIONS	DECIMALS	ANGLES
±	± .005	±
±	± .002	±

CONTRACT NO. \_\_\_\_\_

APPROVALS: \_\_\_\_\_ DATE: \_\_\_\_\_

DRAWN: *[Signature]* DATE: *12/5/03*

CHECKED: *[Signature]* DATE: *12/10/03*

**Gremlin Industries, Inc.**  
San Diego, California 92122

ASSEMBLY CONTROL PANEL  
MOON CRESTA

SIZE: \_\_\_\_\_ CODE IDENT NO: \_\_\_\_\_ DRAWING NO: *MR-2000* REV: \_\_\_\_\_

SCALE: \_\_\_\_\_ SHEET OF: \_\_\_\_\_

DO NOT SCALE DRAWING

# 7 Parts Catalog

## Power Supply Assy

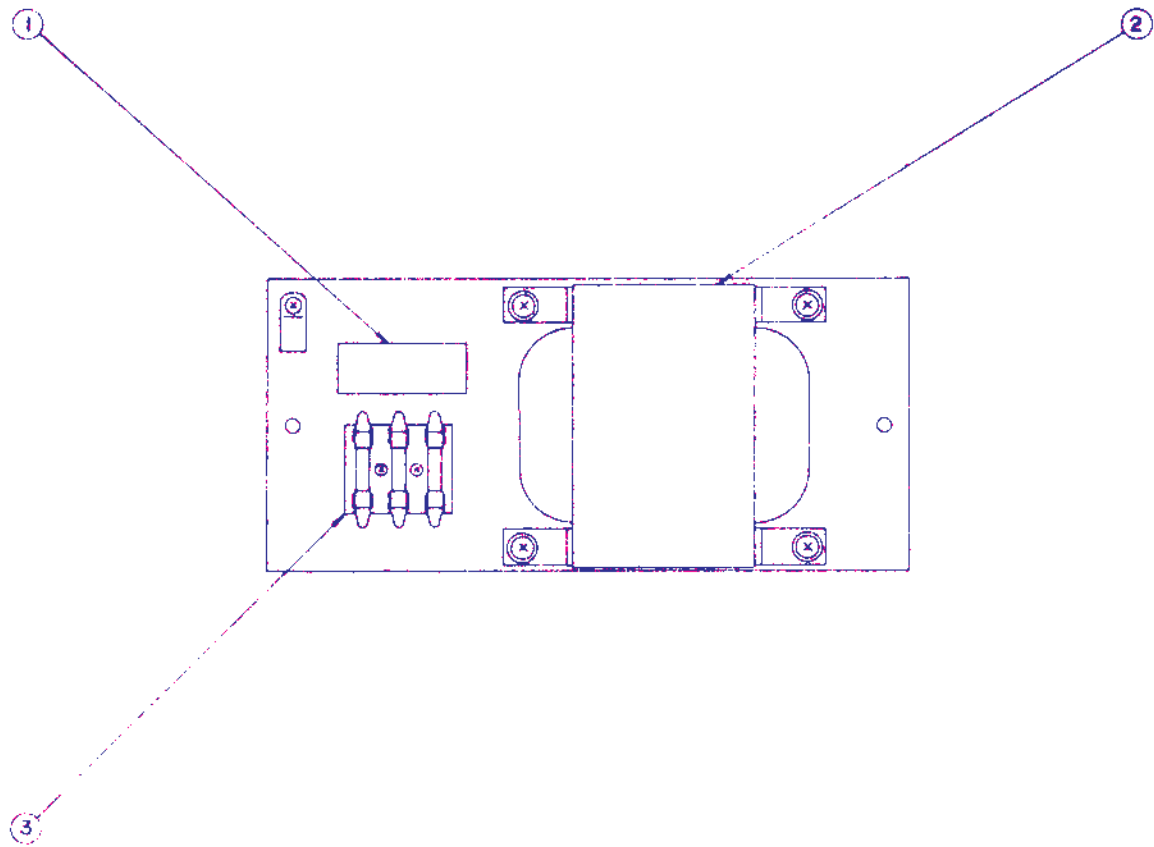

- |   |         |                              |
|---|---------|------------------------------|
| 1 | 83334   | Fuse Instructions            |
| 2 | 97313   | Power Transformer, 100V-240V |
| 3 | S-93003 | Fuse Holder, 3P              |
|   | S-96774 | Fuse, 5A, Time-Lag Type      |

A B C D E F G H

MACHINE	SUB-ASSY
MR 0000	MR 0000
ALTERATIONS	
A AS ADD	199 B20G

102 2-4 3 104+106 5 202 206 207 208

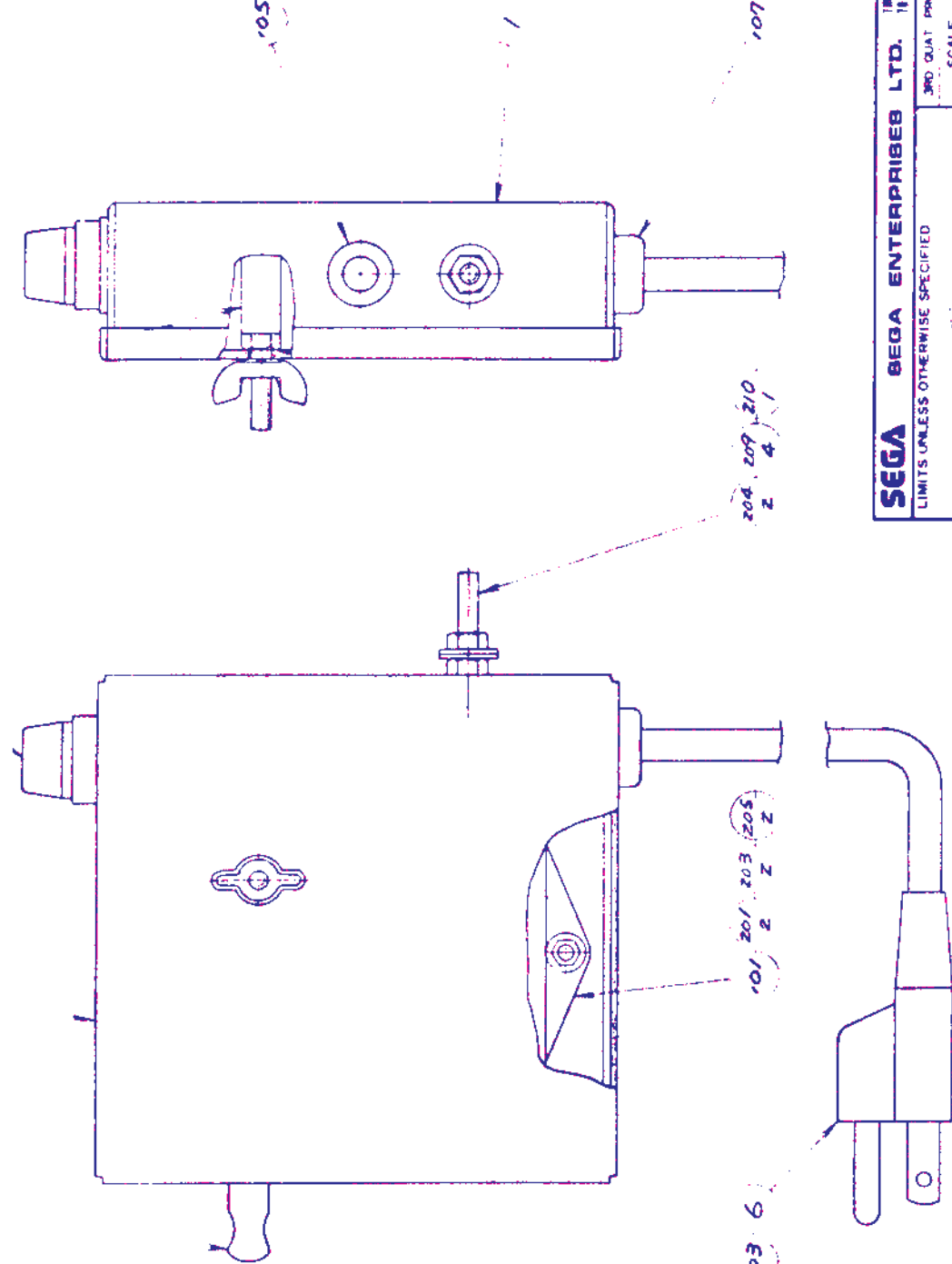

<b>SEGA BEGA ENTERPRISES LTD.</b>		此圖之繪製 均製圖部	
LIMITS UNLESS OTHERWISE SPECIFIED		THIS DRAWING WILL IN NO WAY BE COPIED TO BE REPRODUCED OR REPRODUCED	
3RD QUAT PROJ DRAWING	SCALE	APR 9 24 1951	
DIM IN	DIM IN	ASSY	9/24/50
		CKD	"
		DRW	9/24/50
MATERIAL	HEAT TREAT	REMARK	
JUNCTION BOX ASS'Y		MR-1019 (10-1/2)	
DESCRIPTION		PART NO	

MACHINE	SUB-ASS'Y			
		MR-1000		
ALTERATIONS				
△ CHANGED DESCRIPTION				
△ ADD		200	9/26-80	UL
△ ADD				
△ WAS 111-630		200	9/13-80	UL

210	111-937	1	M. SCREW, P.H. PHILL., BRASS, ISO	M4x25
209	144-269	4	FLAT WASHER, SPECIAL, BRASS	4-12x1
208	133-112	1	WING NUT, ISO	M4
207	133-089	1	HEX. NUT, ISO	M4
206	144-076	1	SPRING WASHER	M4 (*2)
205	144-057	2	FLAT WASHER	M3
204	133-133	2	HEX. NUT, BRASS, ISO	M4
203	133-088	2	HEX. NUT, ISO	M3
202	111-678	1	M. SCREW, F.H. PHILL., ISO	M4x15
△ 201	111-854	2	M. SCREW, F.H. PHILL., ISO	M3x10
△ 111	S-92398	50 <sub>mm</sub>	THERMO-SHRNK TUBE, "HISHILITE" TRANSPARENT, 17.5mm	
110	S-96564	2	TERMINAL LUG, ROUND I.D.5 (AMP 170011-2)	
△ 109	S-91978-1	*3	SOCKET ELEMENT (AMP 170147-1)	
108	S-93542-1	1	SOCKET, 3P, BROWN (AMP 1-480304-1)	
107	S-96148	1	BUSHING, STRAIN RELIEF, 8.3 (HEYCO SR-6N-4)	
106	S-96774	*1	FUSE, 5A, TIME-LAG TYPE, 6.35 <sup>ø</sup> x31.75mm (NAGASAWA 61T5)	
105	S-92310	1	RUBBER GROMMET, 7 <sup>ø</sup> x10 <sup>ø</sup> x4.5 (TAKIGEN 19-79-C)	
△ 104	S-90207	1	FUSE HOLDER, <sup>W</sup> /SCREW CAP (SATO F-4000) (UL STANDARD ROUND TYPE)	
103	S-95835	1	CABLE & PLUG ASSY, <sup>W</sup> /EARTH, 0.16x41x3, L=3m (CHERRY 579-30A)	
102	S-94339	1	SWITCH, MICRO TYPE, DEPT. CHEAT INTER LOCK TYPE	
101	S-94972	1	NOISE FILTER, AC 250V, 2A (TDK 29B 220Z-01)	
6	97339	1	CHOKE, 14H	
5	FL-3237	1	SPACER TUBE, 26	
4	81319	1	STICKER, 120V	
3	80426	1	STICKER, 5 AMPERE	
2	MR-1021	1	COVER	
1	MR-1020	1	JUNCTION BOX	

D.NO	POS.	PART NO.	Q/U	DESCRIPTION	NOTE
					APR. 9. 22 1980
					DRAFT. 9/14/80
JUNCTION BOX ASS'Y				PARTS LIST:	MR-1019(D-7/2)
DESCRIPTION					PART NO.

1	2	3	4	5	6	7	8	9	10	11	12	13	14	15	16	17	18	19	20	21	22	23	24	25	26	27	28	29	30	31	32	33	34	35	36	37	38	39	40	41	42	43	44	45	46	47	48	49	50	51	52	53	54	55	56	57	58	59	60	61	62	63	64	65	66	67	68	69	70	71	72	73	74	75	76	77	78	79	80	81	82	83	84	85	86	87	88	89	90	91	92	93	94	95	96	97	98	99	100
---	---	---	---	---	---	---	---	---	----	----	----	----	----	----	----	----	----	----	----	----	----	----	----	----	----	----	----	----	----	----	----	----	----	----	----	----	----	----	----	----	----	----	----	----	----	----	----	----	----	----	----	----	----	----	----	----	----	----	----	----	----	----	----	----	----	----	----	----	----	----	----	----	----	----	----	----	----	----	----	----	----	----	----	----	----	----	----	----	----	----	----	----	----	----	----	----	----	----	-----

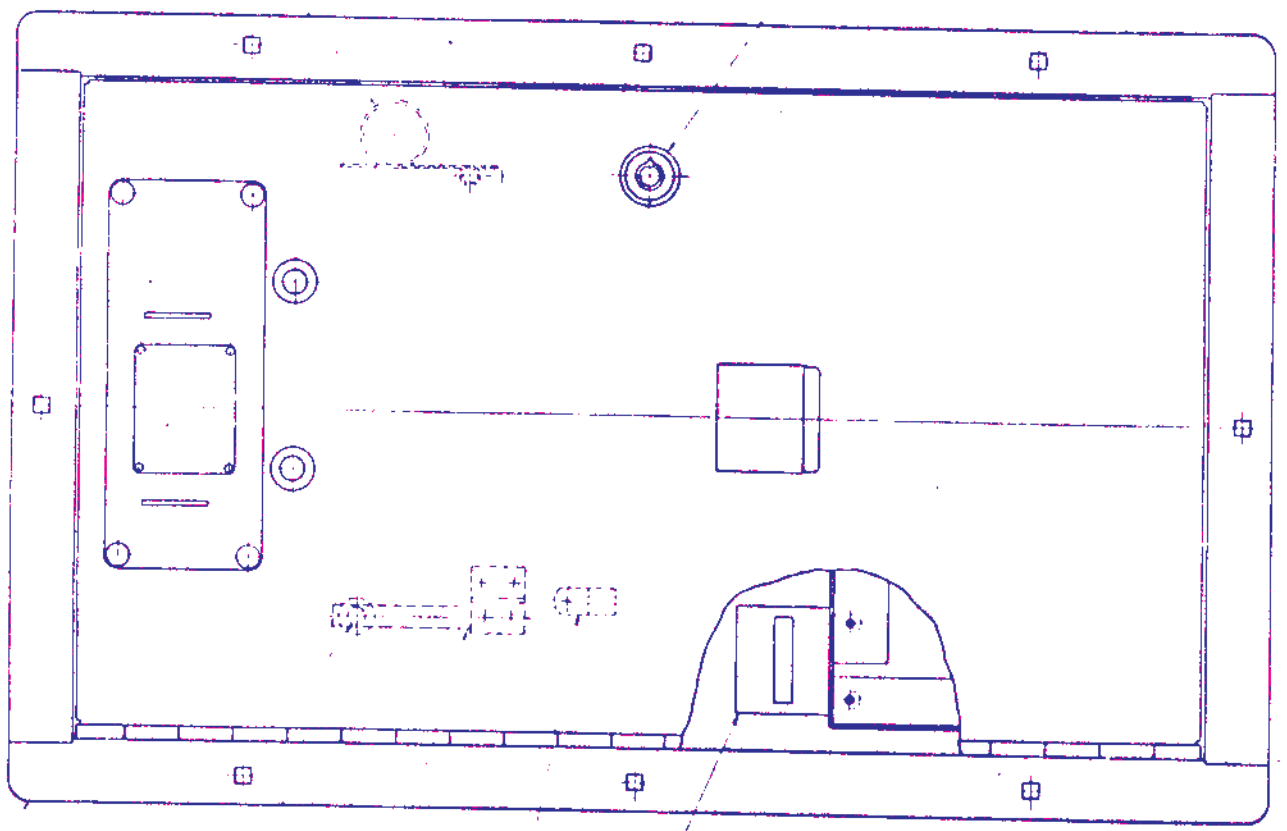
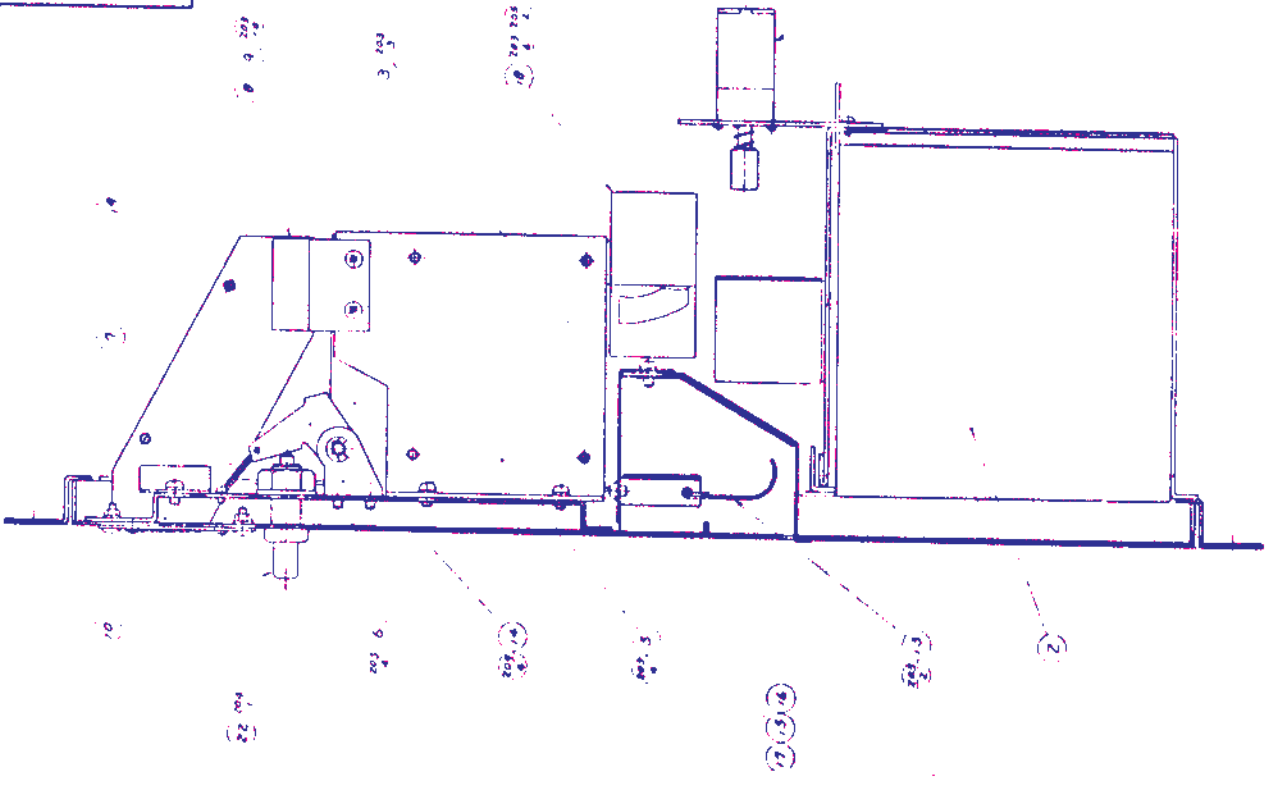



MACHINE	SUB-ASSY			
	MR-1000			
ALTERATIONS				

101	S-9018L	1	CLAMP, CORD, PLASTIC, 8mm, I.D.
25	80931	1	STICKER, COIN METER
24	90303E-5-P	1	MAGNET COUNTER, 6 DIGITS, DC 5V
23	80824	1	DENOMINATION PLATE, 25¢
22	30060	1	KEY HOLDER
21	SK-1057	1	TILT SWITCH ASS'Y, IM.
20	SK-1042	1	SWITCH BRACKET
19	CC-2006	2	COIN CHUTE, REJECTOR TYPE, 25¢ x 1
18	CC-2050	2	COIN CHUTE BRACKET ASS'Y
17	LS-1064	1	ACE CYLINDER LOCK, L.S. TYPE
16	PB-1022	1	LOCK TONGUE
15	SW-1108	1	SPACER RING
14	SH-1007	2	SHAFT
13	MF-1010	1	FLAP DOOR ASS'Y
12	OL-3018	2	EXTENSION SPRING
11	MO-1245	1	COIN ENTRY PLATE, U.S.A. 25¢ x 2
10	MP-1017	2	REJECT BUTTON ASS'Y
9	DH-1046	2	COIN ENTRY BRACKET, B
8	DH-1045	2	COIN ENTRY BRACKET, A
7	DH-1044	2	REJECT LEVER
6	DH-1043	2	REJECT LEVER BRACKET
5	DH-1042X	2	COIN CHUTE BRACKET
4	MR-1204	1	ADJUSTMENT UNIT
3	MR-1203	1	COVER
2	MR-1202	1	CASH BOX
1	MR-1201	1	COIN CHUTE DOOR

D NO	POS.	PART NO	Q/U	DESCRIPTION	NOTE
------	------	---------	-----	-------------	------

				APR. 9 20 1980
				DRAFT. 9/2/80
COIN CHUTE DOOR & CASH BOX ASS'Y			PARTS LIST	MR-1200 (D-3/3)
DESCRIPTION				PART NO

MACHINE	SUB-ASSY
	MR-1200
ALTERATIONS	

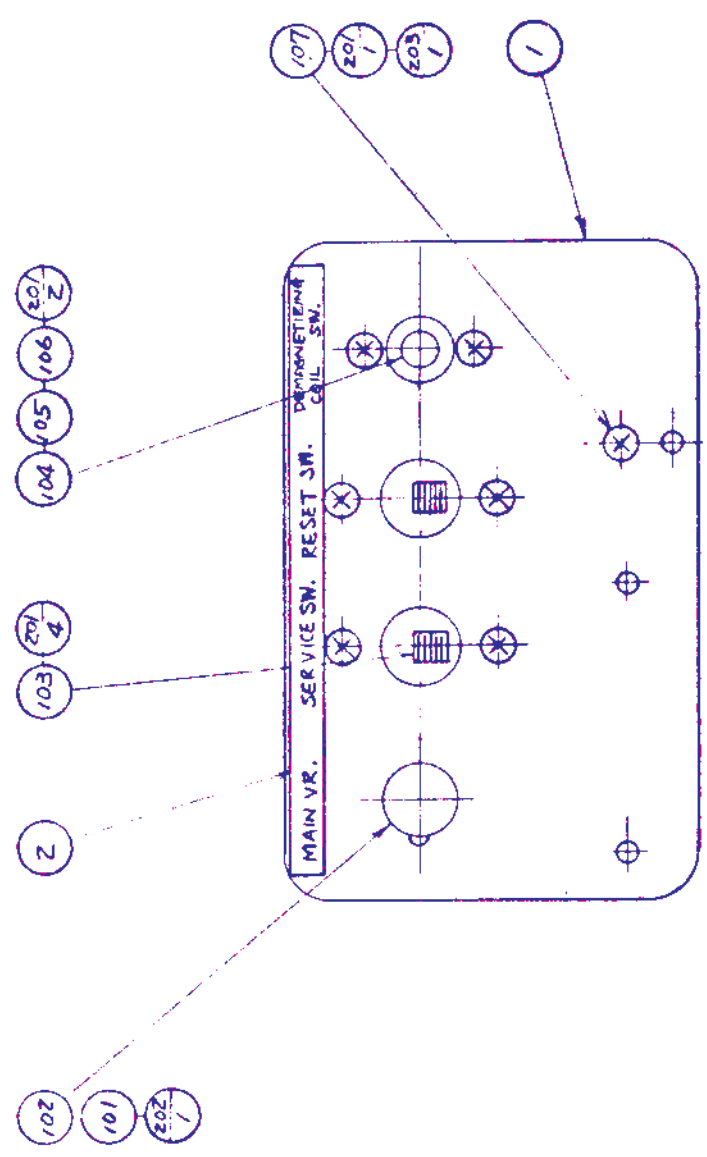

<b>SEGA BEGA ENTERPRISES LTD.</b>		THIS DRAWING WILL BE ON HAND BE COPIED. 此圖將被保留	
LIMITS UNLESS OTHERWISE SPECIFIED		3RD QUAT PROJ DRAWING	
SCALE	1	APR	9/60
DIM IN	mm	ASSY	9/60-80
MATERIAL		CK'D	"
HEAT TREAT		DRW	9/18-80
FINISH		REMARK	
ADJUSTMENT UNIT		MR-1204 (D-1/2)	
DESCRIPTION		PART NO.	



# WIRING DIAGRAM

ZONE		LTR		DESCRIPTION	DATE	APPROVED

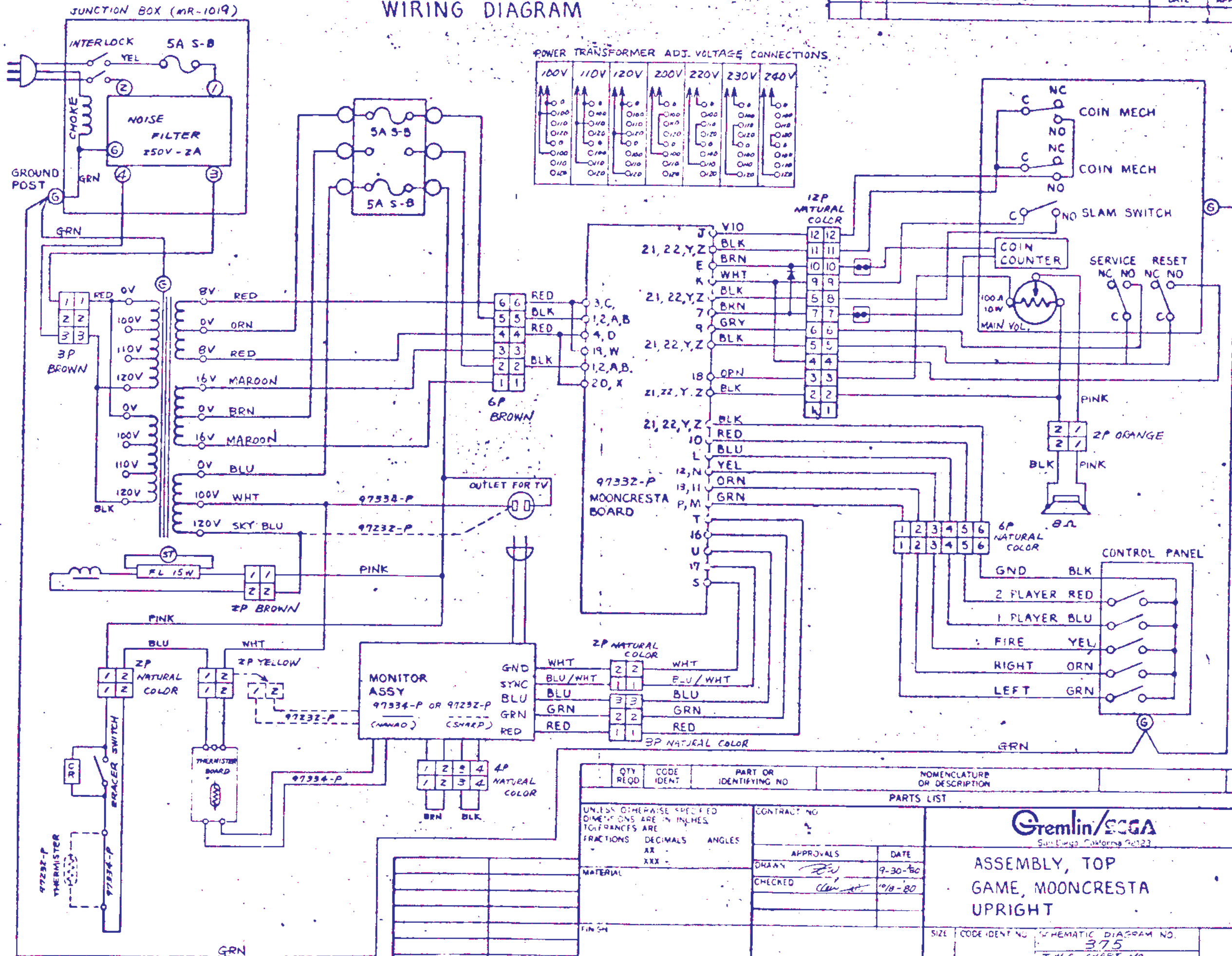

QTY REQD	CODE IDENT	PART OR IDENTIFYING NO	NOMENCLATURE OR DESCRIPTION
PARTS LIST			
UNLESS OTHERWISE SPECIFIED DIMENSIONS ARE IN INCHES TOLERANCES ARE FRACTIONS DECIMALS ANGLES AX XXX -		CONTRACT NO	
MATERIAL		APPROVALS	DATE
FINISH		DRAWN <i>[Signature]</i>	9-30-80
NEXT ASSY		CHECKED <i>[Signature]</i>	10-18-80
USED ON		<b>ASSEMBLY, TOP GAME, MOONCRESTA UPRIGHT</b>	
APPLICATION			
DO NOT SCALE DRAWING		SIZE	CODE IDENT NO
		SCHEMATIC DIAGRAM NO. 375	
		TWC CHART NO. SGB-2835	
		SCALE NONE	SHEET OF

700-0030 | A

8          7          6          5          4          3          2          1

MAIN I.C. BOARD SHT 1

REVISIONS			
ZONE	LTR	DESCRIPTION	DATE

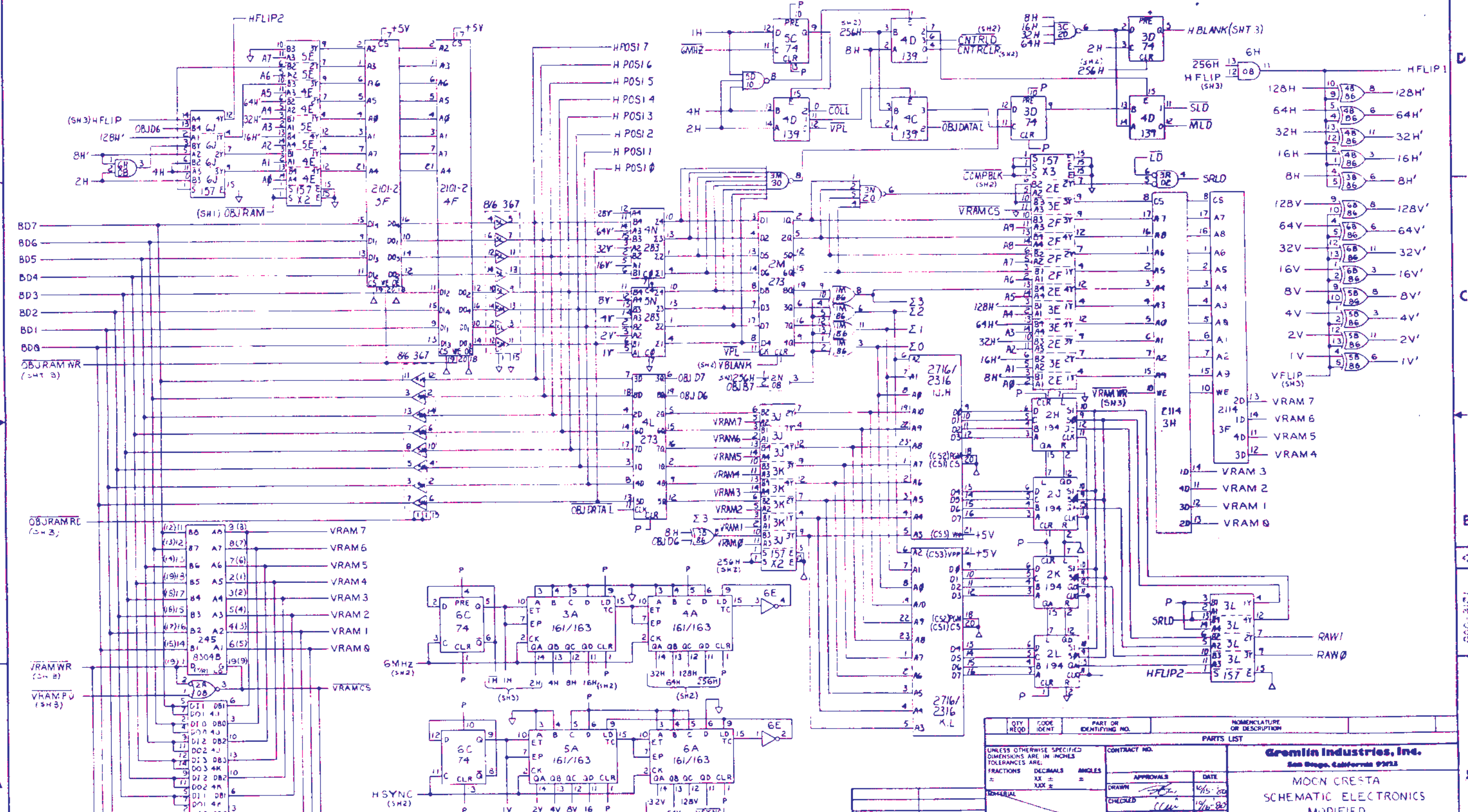

- NOTES UNLESS OTHERWISE STATED
- 1. ALL RESISTANCE VALUES ARE IN OHMS, 1/8 WATT.
  - 2. ALL CAPACITANCE VALUES ARE IN MICRO FARADS, CERAMIC.
  - 3. POLARIZED CAPACITORS ARE TANTALUM.
  - 3. FOR MODIFICATION PROCEDURE SEE DRAWING # 800-3110.

QTY REQD		CODE IDENT	PART OR IDENTIFYING NO.		NOMENCLATURE OR DESCRIPTION	
PARTS LIST						
UNLESS OTHERWISE SPECIFIED DIMENSIONS ARE IN INCHES TOLERANCES ARE:			CONTRACT NO.			
FRACTIONS DECIMALS ANGLES			APPROVALS			
= = =			DATE			
DRAWN			CHECKED			
DATE			DATE			
DRAWN			CHECKED			
DATE			DATE			
DRAWN			CHECKED			
DATE			DATE			
Gremlin Industries, Inc. San Diego, California 92121						
MOON CRESTA SCHEMATIC ELECTRONICS MODIFIED						
SHEET		CODE IDENT NO.		DRAWING NO.		SCALE NONE
8		97332-P		SHEET		OF

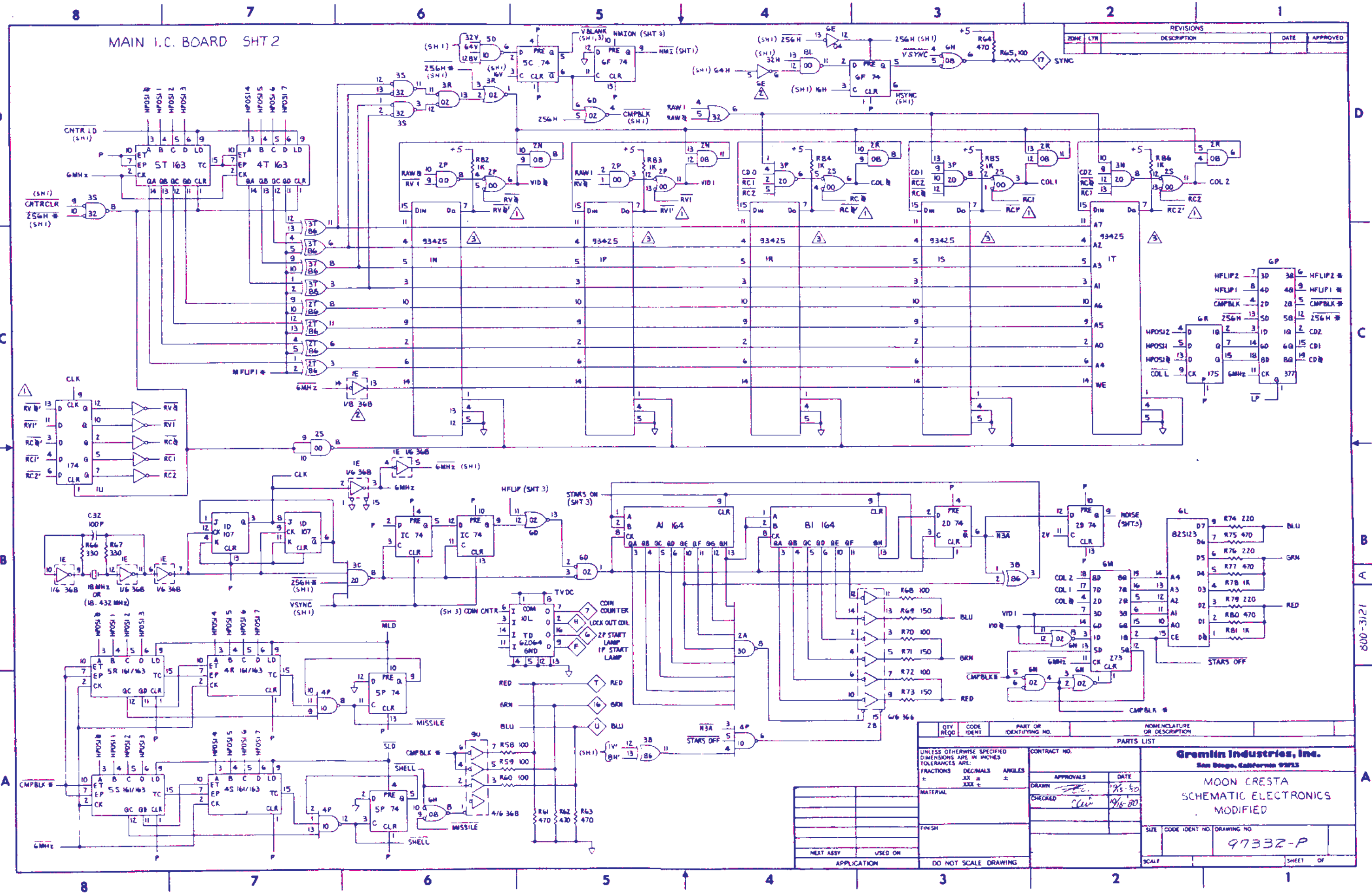

REVISIONS			
ZONE	LTR	DESCRIPTION	DATE

PARTS LIST			
QTY	REQD	CODE IDENT	PART OR IDENTIFYING NO.

NOMENCLATURE OR DESCRIPTION			
PARTS LIST			
UNLESS OTHERWISE SPECIFIED DIMENSIONS ARE IN INCHES TOLERANCES ARE:			
FRACTIONS	DECIMALS	ANGLES	
±	±	±	±
MATERIAL			
FINISH			
NEXT ASSY	USED ON		
APPLICATION	DO NOT SCALE DRAWING		

**Gremlin Industries, Inc.**  
 San Diego, California 92123

MOON CRESTA  
 SCHEMATIC ELECTRONICS  
 MODIFIED

97332-P

SCALE: \_\_\_\_\_ SHEET OF: \_\_\_\_\_

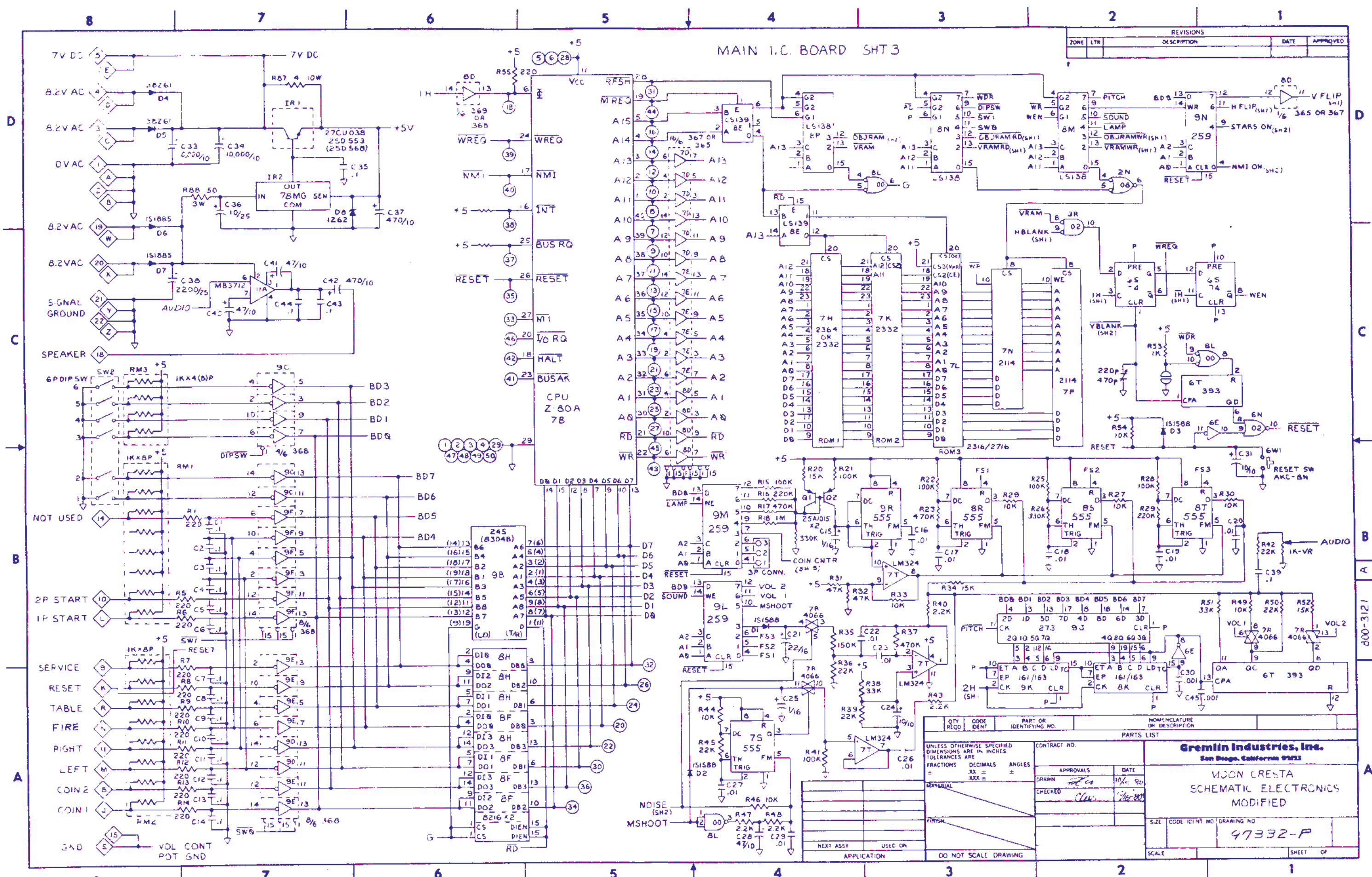

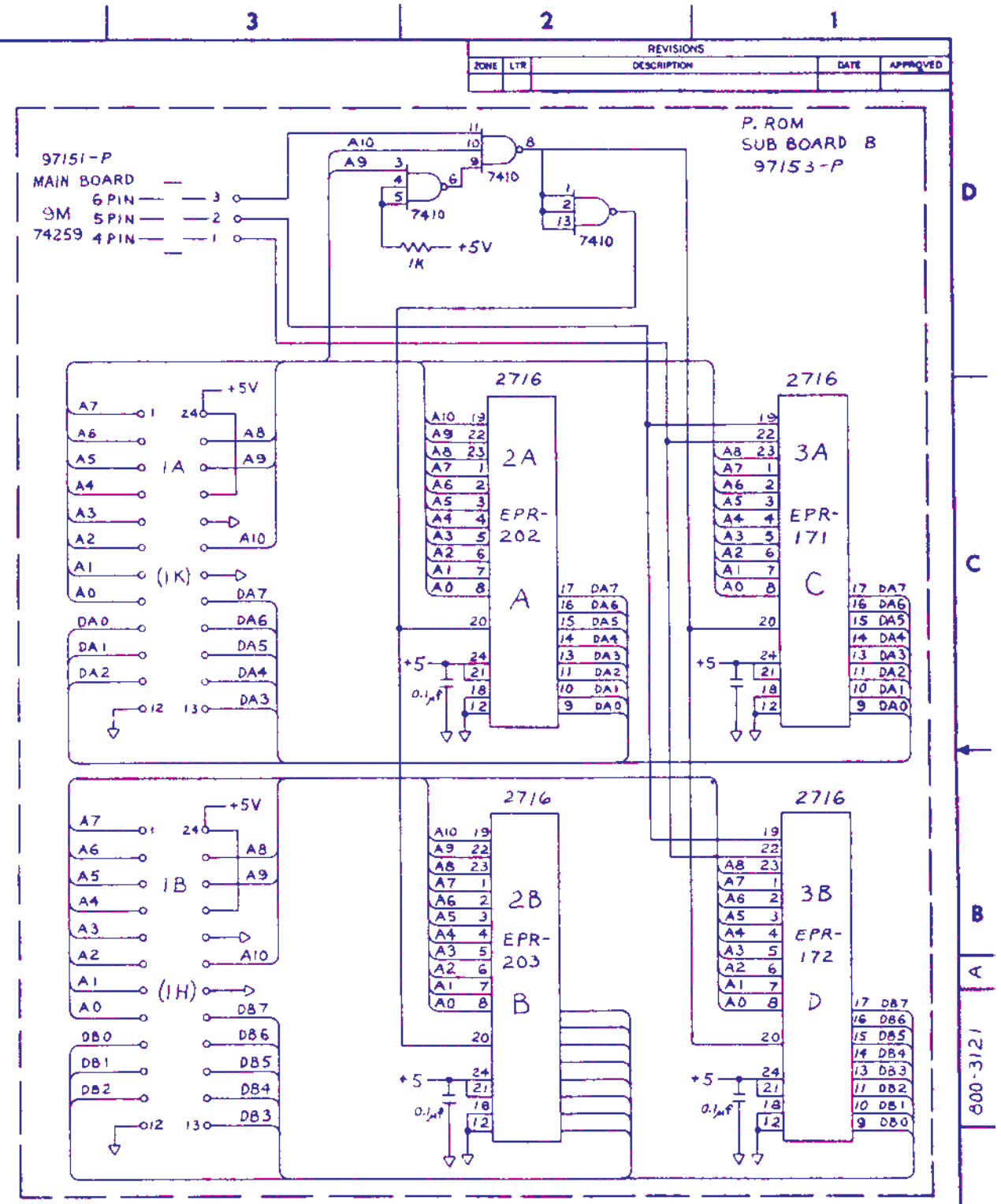
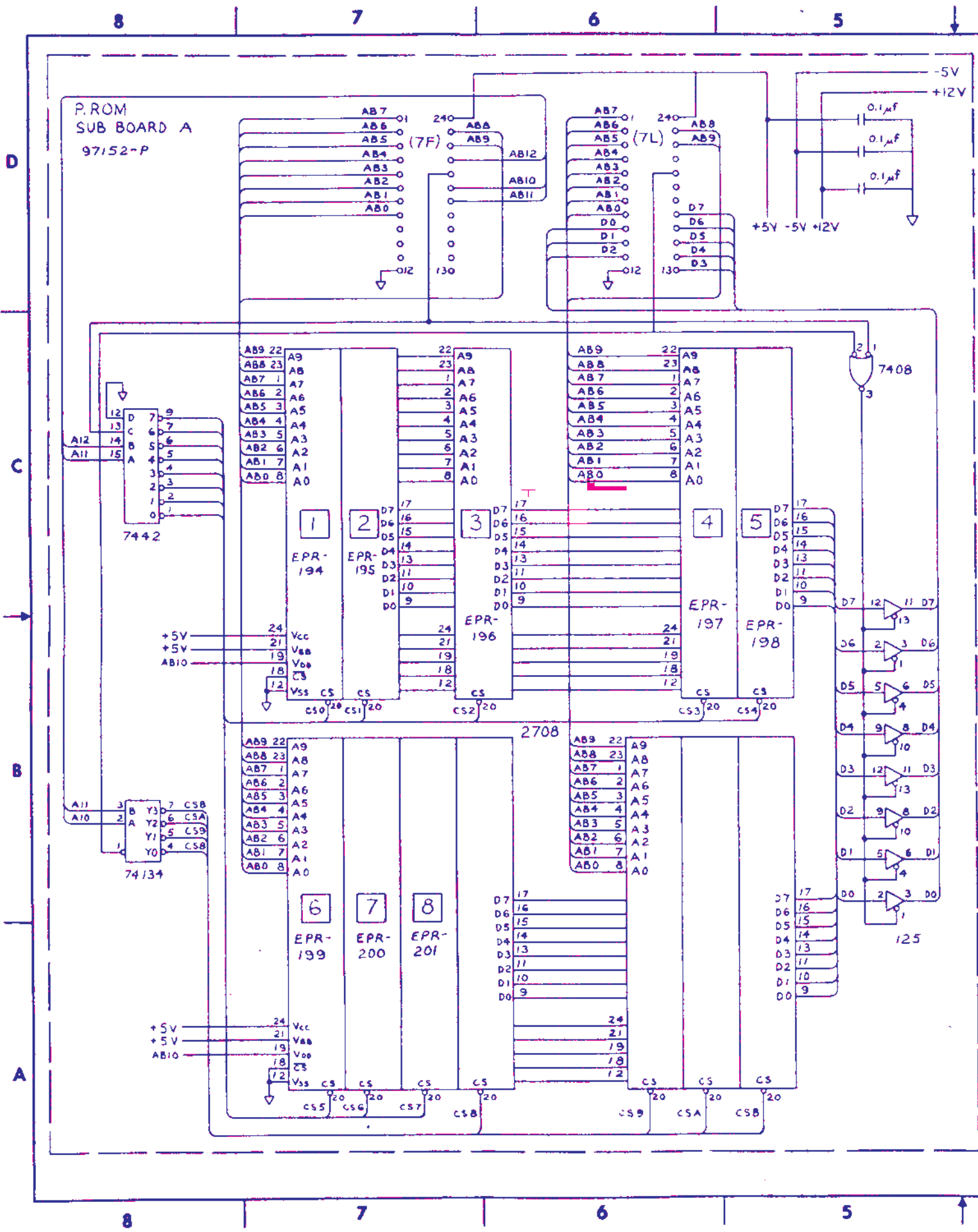

REVISIONS				
ZONE	LTR	DESCRIPTION	DATE	APPROVED

QTY REQD	CODE IDENT	PART OR IDENTIFYING NO.	NOMENCLATURE OR DESCRIPTION
PARTS LIST			
UNLESS OTHERWISE SPECIFIED DIMENSIONS ARE IN INCHES TOLERANCES ARE:		CONTRACT NO.	
FRACTIONS ±	DECIMALS .XX ±	APPROVALS	
ANGLES XXX ±		DATE	
MATERIAL		DRAWN <i>[Signature]</i> 12/5-80	
FINISH		CHECKED <i>[Signature]</i> 12/5-80	
NEXT ASSY USED ON		SIZE CODE IDENT NO DRAWING NO	
APPLICATION		97152-P	
DO NOT SCALE DRAWING		97153-P	
SCALE		SHEET OF	

**Gromlin Industries, Inc.**  
San Diego, California 92123

MOON CRESTA  
SCHEMATIC ELECTRONICS  
MODIFIED



REVISIONS				
ZONE	LTR	DESCRIPTION	DATE	APPROVED

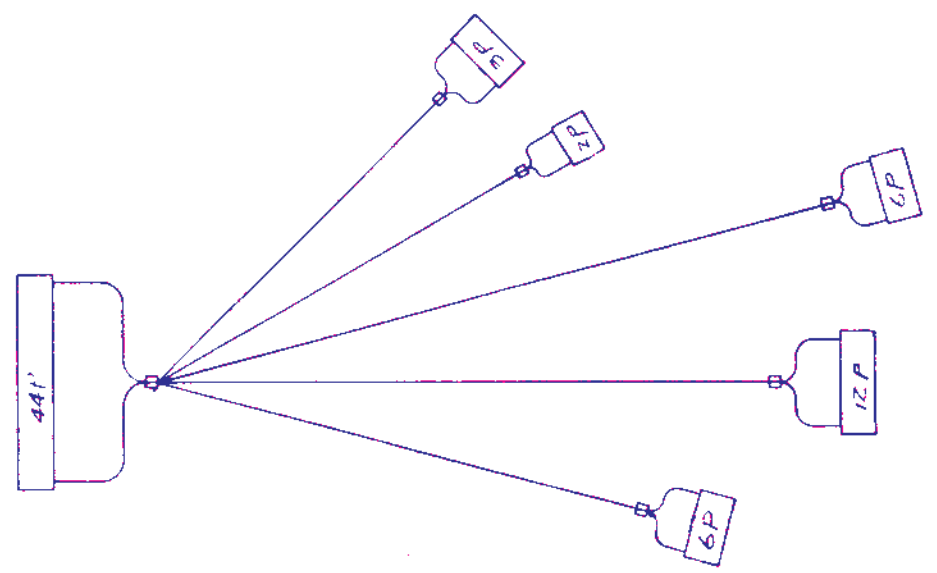
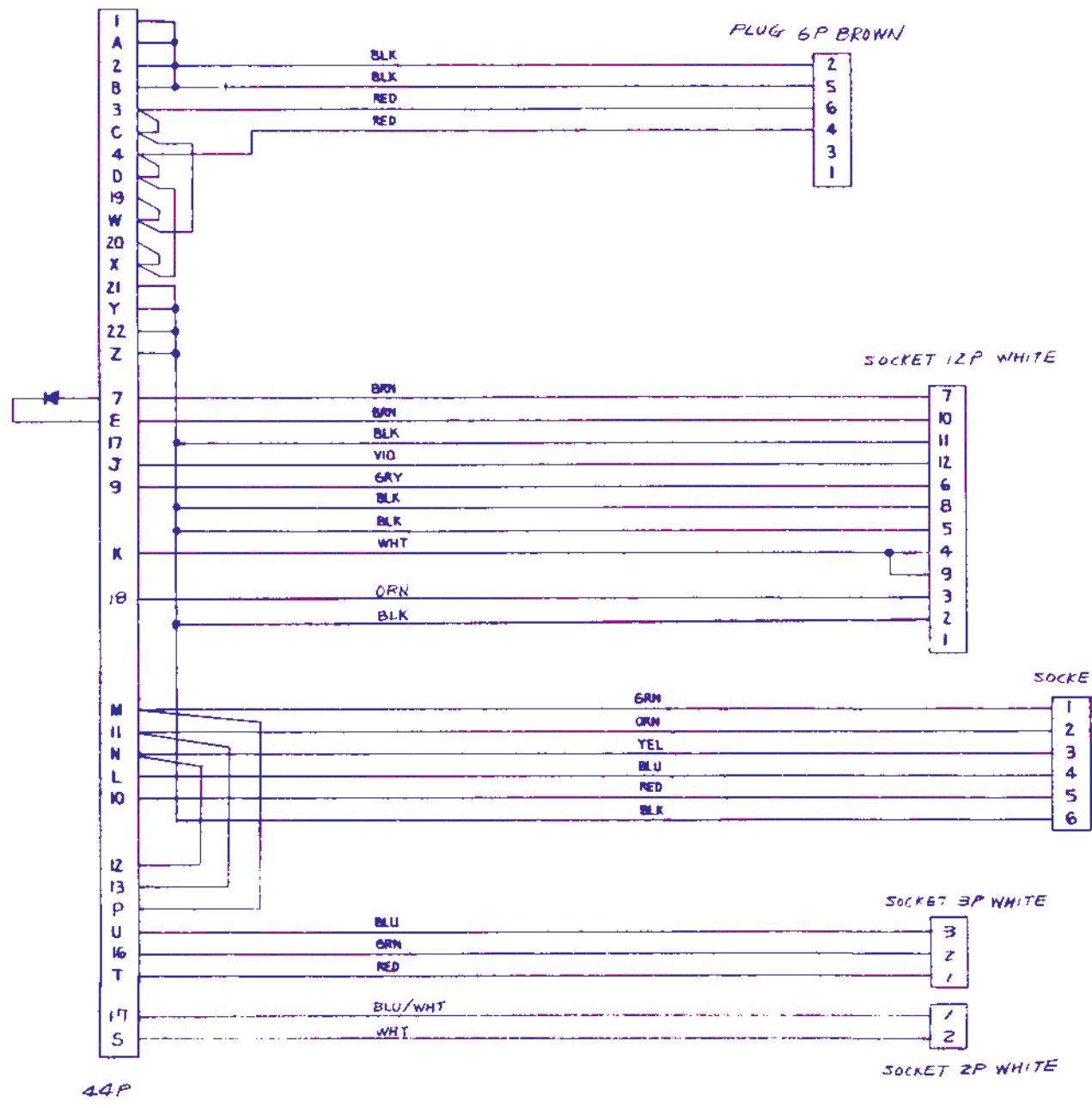

UNLESS OTHERWISE SPECIFIED DIMENSIONS ARE IN INCHES TOLERANCES ARE:		CONTRACT NO.		Gremlin Industries, Inc. San Diego, California 92133	
FRACTIONS	DECIMALS	ANGLES	APPROVALS	DATE	ASSY HARNESS MASTER M/C
±	±	±			
MATERIAL	FINISH	DO NOT SCALE DRAWING	DRAWN		SIZE
			CHECKED		CODE IDENT NO.
700 - 0030					DRAWING NO.
NEXT ASSY	USED ON				SGR-2835-1
APPLICATION					REV.
					-5
					SCALE NONE
					SHEET OF

800-3104