



OPERATIONS MANUAL



OPERATIONS MANUAL INCLUDES

Operations & Adjustments • Testing & Problem Diagnosis • Parts Information
Wiring Diagrams & Schematics

Williams Electronics Games, Inc., 3401 N. California Avenue, Chicago, IL 60618

DIP SWITCH SETTINGS AND JUMPERS

EPROM Jumper Settings for G11		W1	W2
1MEG, 2MEG, 4 MEG EPROM		In	Out

DIP Switch Chart

COUNTRY	SW1	SW2	SW3	SW4	SW5	SW6	SW7	SW8
AMERICA	Off	Off	On	On	On	On	On	On
EUROPEAN	Off	Off	On	On	On	Off	On	On
FRENCH	Off	Off	On	On	On	On	Off	Off
GERMAN	Off	Off	On	On	On	On	On	Off
SPAIN	Off	Off	On	On	Off	On	On	On

SOLENOID/FLASHER TABLE

Sol. No.	Function	Solenoid Type	Voltage Connections			Drive Xlator	Drive Connections			Drive Wire Color	Solenoid Part Number	
			Playfield	Insert	Cabinet		Playfield	Insert	Cabinet		Flashlamp Type	Playfield
01	AUTO PLUNGER	High Power	J133-2			Q72	J116-1			VIO-BRN	AE-24-900	
02	BRIDE POST	High Power	J133-2			Q68	J116-2			VIO-RED	AE-26-1500	
03	MUMMY COFFIN	High Power	J133-2			Q71	J116-4			VIO-ORG	AE-27-1200	
04	NOT USED	High Power				Q67				VIO-YEL		
05	LEFT GATE	High Power	J133-2			Q70	J116-6			VIO-GRN	A-14406	
06	RIGHT GATE	High Power	J133-2			Q66	J116-7			VIO-BLU	A-14406	
07	NOT USED	High Power				Q69				VIO-BLK		
08	RAMP LOCK POST	High Power	J133-2			Q65	J116-9			VIO-GRY	AE-27-1200	
09	TROUGH EJECT	Low Power	J133-3			Q44	J113-1			BRN-BLK	AE-26-1500	
10	LEFT SLINGSHOT	Low Power	J133-3			Q48	J113-3			BRN-RED	AE-26-1200	
11	RIGHT SLINGSHOT	Low Power	J133-3			Q43	J113-4			BRN-ORG	AE-26-1200	
12	LEFT JET BUMPER	Low Power	J133-3			Q47	J113-5			BRN-YEL	AE-26-1200	
13	RIGHT JET BUMPER	Low Power	J133-3			Q42	J113-6			BRN-GRN	AE-26-1200	
14	BOTTOM JET BUMPER	Low Power	J133-3			Q46	J113-7			BRN-BLU	AE-26-1200	
15	LEFT EJECT	Low Power	J133-3			Q41	J113-8			BRN-VIO	AE-30-2000	
16	RIGHT POPPER	Low Power	J133-3			Q45	J113-9			BRN-GRY	AE-25-1000	
17	WOLFMAN FLASHERS	Flasher	J133-6	J134-5		Q28	J111-1	J112-1		BLK-BRN	#906 (2)	#906
18	BRIDE FLASHERS	Flasher	J133-6	J134-5		Q32	J111-2	J112-2		BLK-RED	#89	#906
19	FRANKENSTEIN FLASHERS	Flasher	J133-6	J134-5		Q27	J111-3	J112-3		BLK-ORG	#906 (2)	#906
20	DRACULA COFFIN FLASHERS	Flasher	J133-6	J134-5		Q31	J111-4	J112-5		BLK-YEL	#89	#906
21	CREATURE FLASHERS	Flasher	J133-6			Q26	J111-5			BLU-GRN	#906 (2)	
22	JETS/MUMMY FLASHERS	Flasher	J133-6	J134-5		Q30	J111-6	J112-7		BLU-BLK	#906 (2)	#906
23	RIGHT POPPER FLASHER	Flasher	J133-6			Q25	J111-7			BLU-VIO	#906	
24	FRANK ARROW FLASHER	Flasher	J133-6			Q29	J111-8			BLU-GRY	#906	
25	MONSTERS OF ROCK FLSHR	Gen. Purpose	J133-6	J134-5		Q16	J109-1	J108-1		BLU-BRN	#906	#906
26	WOLFMAN LOOP FLASHERS	Gen. Purpose	J133-6			Q15	J109-2			BLU-RED	#906 (2)	
27	FRANKENSTEIN MOTOR	Gen. Purpose	J140-2			Q14	J109-3			BLU-ORG	14-8015	
28	UP/DOWN BANK MOTOR	Gen. Purpose	J140-2			Q13	J109-4			BLU-YEL	14-8015	
Flipper Circuits		Solenoid Type	Playfield Voltage Connection		Drive Xlators Power	Hold	Playfield Drive Connections		Drive Wire Colors	Hold	Coil Part No.	Coil Colors
29	LOWER RIGHT FLIPPER	Power	J119-1 (RED-GRN)		Q90		J120-13		YEL-GRN		FI-11629	BLUE
30		Hold	J119-1 (RED-GRN)			Q92	J120-11		ORG-GRN			
31	LOWER LEFT FLIPPER	Power	J119-4 (RED-BLU)		Q87		J120-9		YEL-BLU		FL-11629	BLUE
32		Hold	J119-4 (RED-BLU)			Q89	J120-7		ORG-BLU			
33	NOT USED	Power	J119-6 (RED-VIO)		Q84		J120-6		YEL-VIO			
34		Hold	J119-6 (RED-VIO)			Q86	J120-4		ORG-VIO			
35	NOT USED	Power	J119-8 (RED-GRY)		Q81		J120-3		YEL-GRY			
36		Hold	J119-8 (RED-GRY)			Q83	J120-1		ORG-GRY			
Dracula Motor		Solenoid Type	Playfield Voltage Connection		Drive Gates		Playfield Drive Connections		Drive Wire Colors		Device Part Number	
37	DRACULA MOTOR FORWARD	Low Power	J141-2		U3A, U3B		J110-1		BRN-WHT		14-8034	
38	DRACULA MOTOR BACKWARD	Low Power	J141-2		U3C, U3D		J110-3		ORG-WHT			
General Illumination		Solenoid Type	Voltage Connections			Drive Xlator	Drive Connections			Drive Wire	Bulb Type	
01	BOTTOM PLAYFIELD	G.I.	J105-1			Q5	J105-7			WHT-BRN	#44	
02	TOP RIGHT PLAYFIELD	G.I.	J105-2			Q4	J105-8			WHT-ORG	#44	
03	TOP LEFT PLAYFIELD	G.I.	J105-3			Q3	J105-9			WHT-YEL	#44	
04	*TOP INSERT PANEL	G.I.		J106-5		Q2		J106-10		WHT-GRN		#555
05	*BOTTOM INSERT PANEL	G.I.	J106-6	J104-3		Q1		J106-11	J104-1	WHT-VIO		#555

DECLARATION OF CONFORMITY

WILLIAMS ELECTRONICS GAMES, INC.

3401 N. CALIFORNIA AVE.
CHICAGO, IL 60618
U.S.A.

WE, HEREBY DECLARE UNDER SOLE RESPONSIBILITY THAT
THE MODEL: "MONSTER BASH" 50265,50365,50465,50765,50965,51065,51165,
51365,51465,51865,52065,52165,52265,52365,57265 (PIN)

TO WHICH THIS DECLARATION RELATES IS IN CONFORMITY WITH THE
FOLLOWING EUROPEAN PRODUCT SAFETY DIRECTIVES:

ELECTROMAGNETIC COMPATABILITY DIRECTIVE
(89/336/EEC AND AMENDMENTS 91/C162/08, 92/31/EEC,93/68/EEC

ELECTRICAL EQUIPMENT DESIGNED FOR USE WITHIN
CERTAIN VOLTAGE LIMITS DIRECTIVE
(73/23/EEC AND AMENDMENTS 88/C168/02, 92/C210/01,
93/68/EEC, 94/C199/03, 95/C214/02)

EN 55014:1993 EN55104:1995 EN61000-4-2: 1995
IEC 801-3: 1984 (EN61000-4-3) EN61000-4-4: 1995 EN61000-4-5: 1995
ENV50141: 1993 (EN61000-4-6) EN61000-4-11: 1994 EN60335-1: 1995
IEC 335-2-82 (DRAFT)

Date issued: APRIL 6, 1998

MANUFACTURE'S SIGNATURE

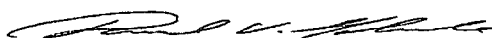

DAN GALARDE
CORPORATE V.P. OF QUALITY

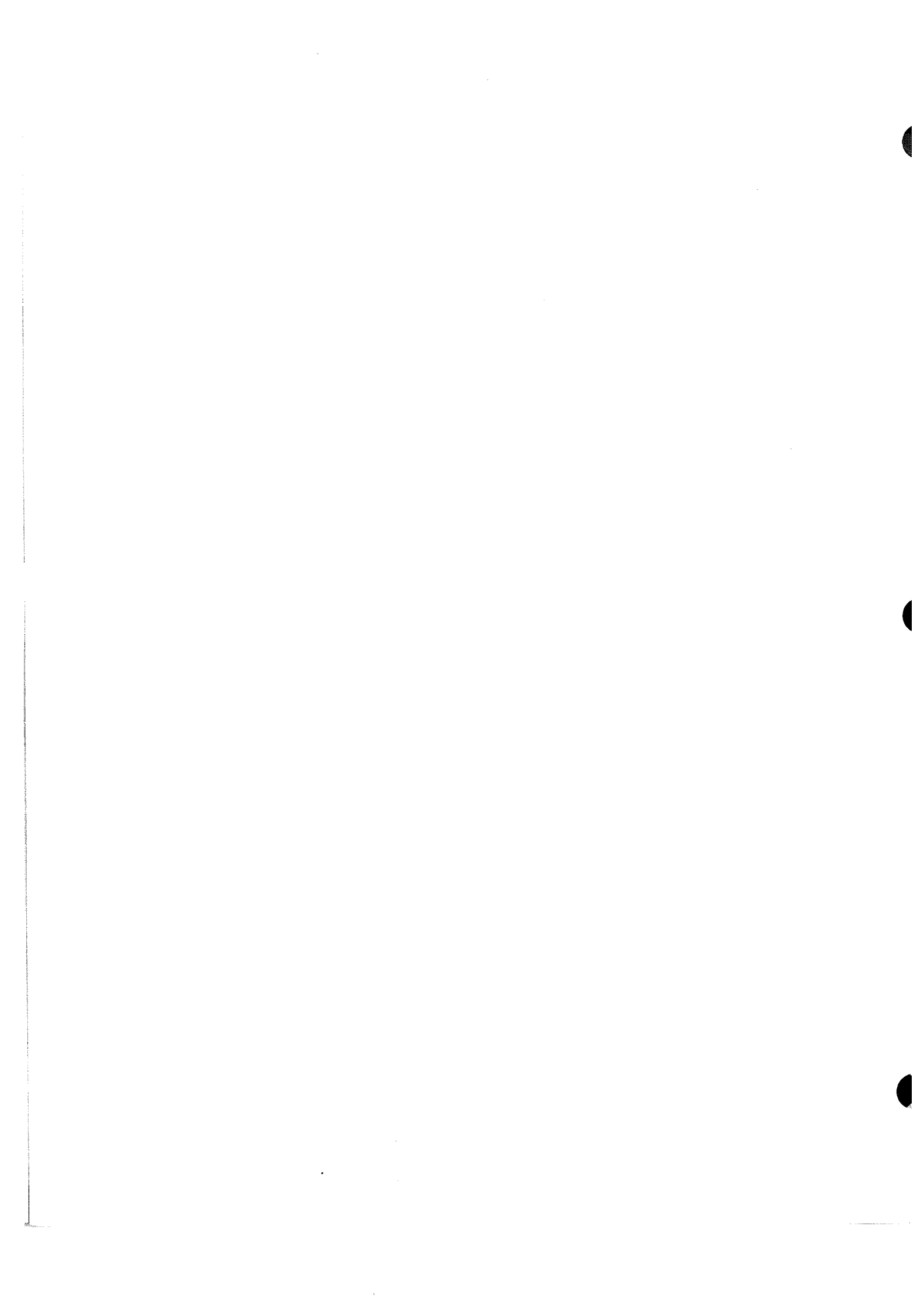

ATTENTION

The Security CPU board has an added security chip that can be interchanged between other **MONSTER BASH** games and software revision levels. The CPU board itself is interchangeable with later model games, but must be equipped with the correct security chip and software for that specific game.

The games' electronic ID number is shown in the display during power-up. The number displayed is the same nine-digit number printed on the security chip label. The first three digits are the project number without the country specific code. An example of the power-up display is shown below, the electronic ID number is bolded.

TESTING		
50065		EPROM 1.0 A
565	100006	95749

IMPORTANT NOTICE

PLEASE READ

This pinball game is equipped with a SAFETY FEATURE to prevent shocks from the solenoid circuit when the coin door is opened. An interlock switch assembly (part no. A-18249-3), located at the left of the coin door opening, has been added to the game. This assembly consists of a bracket containing the existing memory protect switch on the bottom and a new interlock switch on the top. When the coin door is opened, this new interlock switch opens, breaking the connection to the +50V and +20V winding of the transformer secondary.

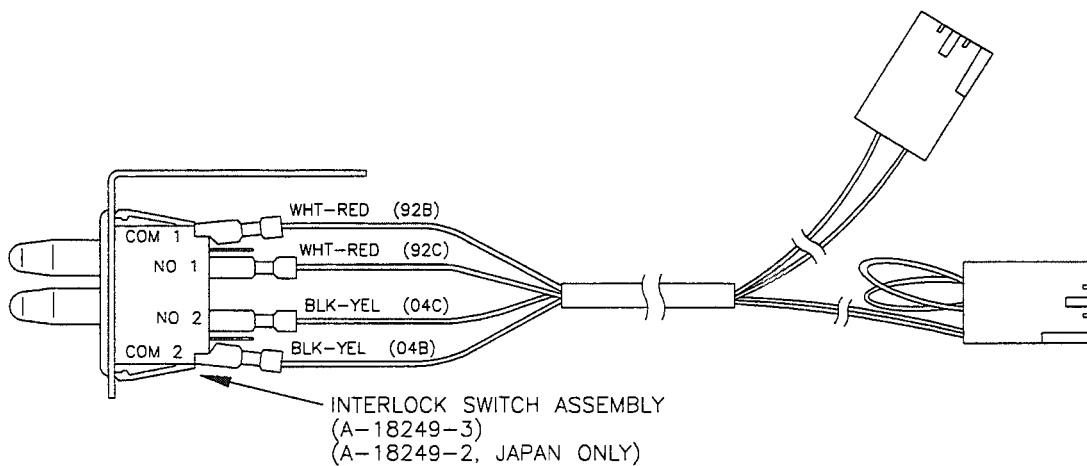

MONSTER BASH

The information is current as of the time of its release.

Fill out and mail in game Registration card. Be sure to include the game serial number. For your records, write the PIC and game serial numbers in manual.

PIC Number _____ Serial Number _____

Williams Electronics Games, Inc. reserves the rights to make modifications and improvements to its products. The specifications and parts identified in this manual are subject to change without notice.

TABLE OF CONTENTS

The MONSTER BASH Rules & Playfield Shots.....	1 to 4
Section 1 - Game Operation & Test Information.....	1-1
(System WPC) ROM Summary.....	1-1
Pinball Game Assembly Instructions.....	1-2
Game Control Locations.....	1-6
Game Operation.....	1-7
Raising the Playfield.....	1-8
Menu System Operation and Main Menu.....	1-9
Bookkeeping Menu.....	1-10
B.1 Main Audits.....	1-10
B.2 Earnings Audits.....	1-10
B.3 Standard Audits.....	1-10
B.4 Feature Audits.....	1-11
B.5 Histograms.....	1-13
B.6 Time-Stamps.....	1-13
Printouts Menu.....	1-14
Test Menu.....	1-15
T.1 Switch Edges Test.....	1-15
T.2 Switch Levels Test.....	1-15
T.3 Single Switch Test.....	1-15
T.4 Solenoid Test.....	1-16
T.5 Flasher Test.....	1-16
T.6 G.I. Test.....	1-16
T.7 Sound and Music Test.....	1-17
T.8 Single Lamp Test.....	1-17
T.9 All Lamps Test.....	1-17
T.10 Lamp and Flasher Test.....	1-17
T.11 Display Test.....	1-17
T.12 Flipper Coil Test.....	1-18
T.13 Ordered Lamp Test.....	1-18
T.14 Lamp Row-Col.....	1-18
T.15 DIP Switch Test.....	1-18
T.16 Loop/Gate Test.....	1-18
T.17 Up/Down Bank Test.....	1-20
T.18 Frankenstein Table Test.....	1-20
T.19 Dracula Test.....	1-20
T.20 Empty Balls Test.....	1-21
Utilities Menu.....	1-22
U.1 Clear Audits.....	1-22
U.2 Clear Coins.....	1-22
U.3 Reset H.S.T.D.....	1-22
U.4 Set Time & Date.....	1-22
U.5 Custom Messages.....	1-22
U.6 Set Game I.D.....	1-22

Section 1 Continued...

U.7 Factory Adjustment.....	1-23
U.8 Factory Reset.....	1-23
U.9 Presets.....	1-23
Game Difficulty Table for U.S., Canadian, French, German, and European Games.....	1-23
Preset Table for U.S./Canada.....	1-23
U.10 Clear Credits.....	1-25
U.11 Auto Burn-in.....	1-25
U.12 Reset Phantom Flip Data.....	1-25
Adjustments Menu.....	1-26
A.1 Standard Adjustments.....	1-26
A.2 Feature Adjustments.....	1-31
A.3 Pricing Adjustments.....	1-36
Pricing Table.....	1-43
A.4 H.S.T.D. Adjustment.....	1-44
A.5 Printer Adjustments.....	1-46
Error Messages.....	1-47
CPU Board & Audio Visual Board Error Codes.....	1-48
Opto Theory.....	1-49
LED List.....	1-50
Fuse List.....	1-51
Maintenance Information.....	1-52

Section 2 - Game Parts Information..... 2-1

Backbox Assembly.....	2-2
Cabinet Assembly.....	2-3
Audio Visual Board Assembly.....	2-4
Power Driver Board Assembly.....	2-6
CPU Security Board.....	2-8
Trough IR LED Board Assembly.....	2-10
Trough IR Photo Transistor Board Assembly.....	2-10
Motor EMI Board Assembly.....	2-10
Coin Door Interface Board Assembly.....	2-11
Flipper Opto Board Assembly.....	2-11
Auto Adjust Eddy Sensor Board.....	2-12
Defender Switch Board Parts List.....	2-12
10-Opto Board Assembly.....	2-13
Defender Switch Board Assembly.....	2-13
DC Motor Control Board Assembly.....	2-14
Ball Gate Actuator Assembly.....	2-15
Eject Assembly.....	2-15
Left Flipper Assembly.....	2-16
Right Flipper Assembly.....	2-17
Kicker Arm (slingshot) Assembly.....	2-18
Ball Trough Assembly Complete.....	2-19

Section 2 Continued...

Jet Coil & Bracket Assembly.....	2-20
Jet Bumper Assemblies.....	2-21
Auto Fire Assembly.....	2-22
Up/Down Post Assembly.....	2-23
Popper Assembly.....	2-24
Bride Mechanism Assembly.....	2-25
Monster Table Assembly Parts List.....	2-26
Monster Table Assembly	2-27
Dracula Assembly.....	2-28
Mummy Assembly.....	2-29
Monster Mechanism Assembly Parts List.....	2-30
Monster Mechanism Assembly.....	2-31
Up/Down Target Assembly Parts List.....	2-32
Up/Down Target Assembly.....	2-33
Creature Mounting Bracket Assembly.....	2-34
Posts.....	2-35
Power Interface Assembly.....	2-36
Power Interface/Cordset Application Chart.....	2-37
Upper Playfield Parts List.....	2-38
Upper Playfield Parts Locations.....	2-39
Lower Playfield Parts List and Locations.....	2-40
Rubber Rings Parts List and Locations.....	2-41
Ball Guides List and Locations.....	2-42
Ramps List and Locations.....	2-43
Lamp Locations List.....	2-44
Lamp Locations.....	2-45
Solenoid/Flashlamp Locations List.....	2-46
Solenoid/Flashlamp Locations.....	2-47
Switch Locations List	2-48
Switch Locations.....	2-50
Switch Matrix.....	2-51
Lamp Matrix.....	2-52
Solenoid/Flashlamp Table.....	2-53

Section 3 - Wiring Diagrams & Schematics.....	3-1
Connector & Component Identification.....	3-1
Switch Matrix and Switch Matrix Circuit.....	3-2
Dedicated Switch Circuit.....	3-3
Lamp Matrix and Lamp Matrix Circuit.....	3-4
Solenoid/Flashlamp Circuit Table.....	3-5
Solenoid Wiring.....	3-6
Flashlamp Wiring.....	3-7
High Power and Low Power Solenoid Circuits.....	3-8
Flashlamp and Special (General Purpose) Solenoid Circuits.....	3-9
General Illumination Circuit.....	3-10

Section 3 Continued...

Flipper Circuit Diagram.....	3-11
Flipper Coil and End-of-Stroke Circuits.....	3-12
Flipper Cabinet Switch Circuits.....	3-13
Flipper Opto Board Assembly.....	3-14
LED and Photo Transistor Board Assemblies	3-15
Trough IR LED Board Assembly.....	3-16
Trough IR Photo Transistor Board Assembly.....	3-17
10-Opto Switch Board Assembly.....	3-18
10-Opto Switch Board Schematic.....	3-19
Individual Playfield Opto Switch Wiring Diagram.....	3-20
Ball Trough Opto Switches Wiring Diagram.....	3-21
Motor EMI Board and Wiring Diagrams for Frankenstein and Up/Down Bank Motors....	3-22
D.C. Motor Board and Wiring Diagram for Dracula Motor.....	3-23
Defender Switch Board and Wiring Diagram for Dracula Assembly Position Location.....	3-24
Auto Adjust Eddy Sensor Board and Wiring Diagram for Left & Right Proximity Sensors	3-25
Auto Adjust Eddy Sensor Board Schematic.....	3-26
Coin Door Interface Board Interboard Wiring List.....	3-27
Coin Door Interface Board Schematic.....	3-28
Security CPU Board Interboard Wiring List.....	3-29
Audio Visual Board Interboard Wiring List.....	3-30
Power Driver Board Interboard Wiring List.....	3-31

NOTES

MONSTER BASH RULES & PLAYFIELD SHOTS

DIABOLICAL DIRECTIONS

SKILL SHOT: Collect flashing light in the top lanes (D-I-G) for points and a random Monster Item. Use flippers to change lanes.

MONSTER FEATURES: Collect monsters by starting each monster's feature.

- CREATURE FEATURE: Shoot lagoon to collect awards.
- BALL & CHAIN: Complete left and right ramps.
- FRANK COMES ALIVE: Collect body parts by hitting Frank targets and shoot Frank ramp to start Multiball.
- MUMMY MAYHEM: Get jet bumper hits to light Mummy Mayhem.
- FULL MOON FEVER: Collect moon phases (loop shots) to start Full Moon Fever.
- DRAC ATTACK: Hit Drac Attack targets to spell DRACULA.

Finish features to collect musical instruments.

EXTRA BALL: Collect monster(s) or shoot Mosh Pit (spinner shot) to light extra ball.

SPECIAL: Collect musical instrument(s) to light Special.

MONSTER BASH: Collect all six monsters to light Monster Bash.

MONSTERS OF ROCK: Collect all six musical instruments to light Monsters of Rock.

MONSTER ITEMS: Shoot Mosh Pit (spinner shot) to collect items. Use Monster Items by hitting launch button during features for easier scoring.

MOSH PIT MULTIBALL: Shoot Mosh Pit (spinner) to light Mosh Pit Multiball.

16-10651

PLAYFIELD SHOTS

LIGHT DIG TO GET INCREASE
JET VALUE & BONUS MULTIPLIER
& 5 HITS TOWARD "MUMMY MAYHEM".

JET BUMPER HITS ADVANCE TO
"MUMMY MAYHEM".

SHOOT LIT ARROWS TO ADVANCE
TO AND LIGHT "MONSTER MOSH PIT".

PHASES OF THE
MOON, WHEN COMPLETE,
BRING OUT THE
WOLFMAN, AND START
"FULL MOON FEVER".

FULL MOON
FEVER
3/4 MOON
HALF MOON
QUARTER
MOON

COMPLETE 6 RAMP SHOTS
TO START "BALL & CHAIN"
MODE (BRIDE OF FRANKENSTEIN)

MONSTER MUSICAL INSTRUMENTS,
(ONE FOR EACH MONSTER). LIGHT ALL
TO LIGHT "MONSTERS OF ROCK".

"ALIVE AGAIN" - SHOOT AGAIN

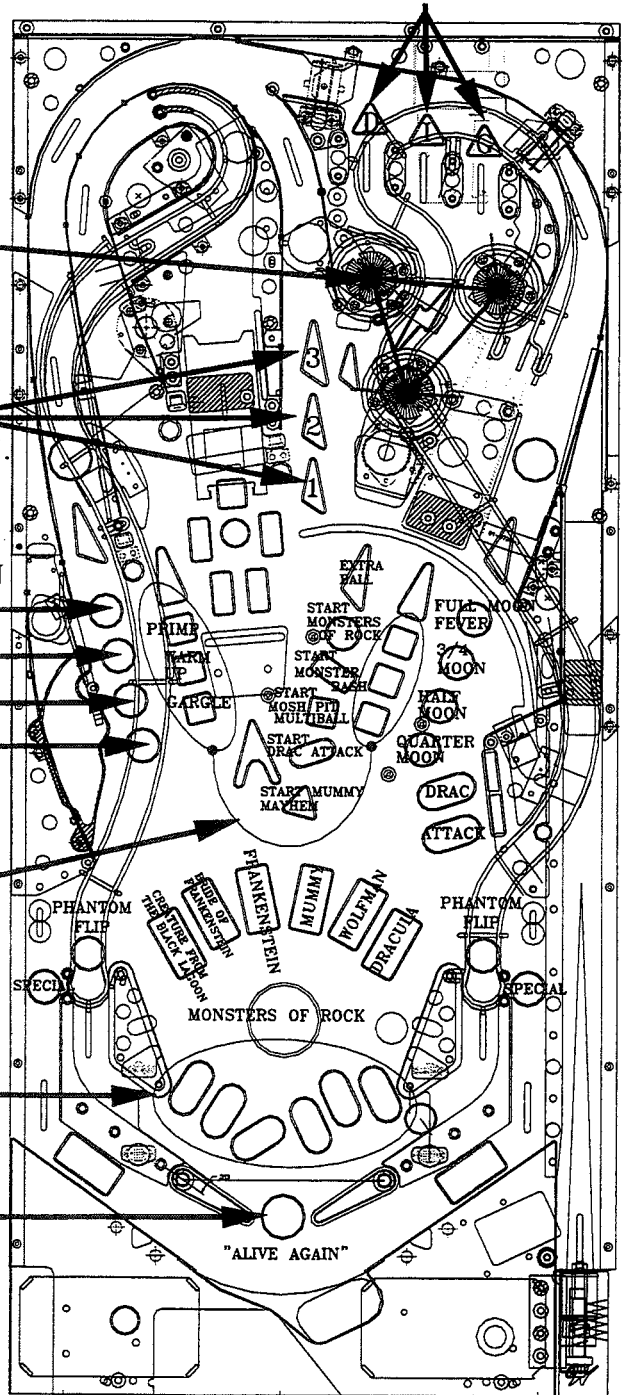

PLAYFIELD SHOTS

"TOMB TREASURES"
HIT "TOMB TREASURES" TARGETS TO GET
10X JETS & 1 BONUS "X".

HITTING ALL 3 TARGETS
LIGHTS "PHANTOM FLIP".

SIGN WITH LAMPS ABOVE PLAYFIELD.

- | | |
|---|-----------|
| ○ | POND SCUM |
| ○ | ALGAE |
| ○ | SEAWEED |
| ○ | MUCK |

CREATURE FEATURE, MAKE 4 SHOTS
TO START MODE.

FRANKENSTEIN'S BODY PARTS,
COLLECT THEM ALL TO LOWER
TARGET AND ALLOW RAMP SHOT
TO START "FRANK COMES ALIVE"
MULTIBALL.

HIT THESE TARGETS TO SPELL
DRACULA AND LIGHT
"DRAC ATTACK".

"PHANTOM FLIP",
THE MACHINE ATTEMPTS TO COMPLETE
THE REQUIRED SHOT WHEN BALL ENTERS
EITHER LANE IF "PHANTOM FLIP" IS LIT.

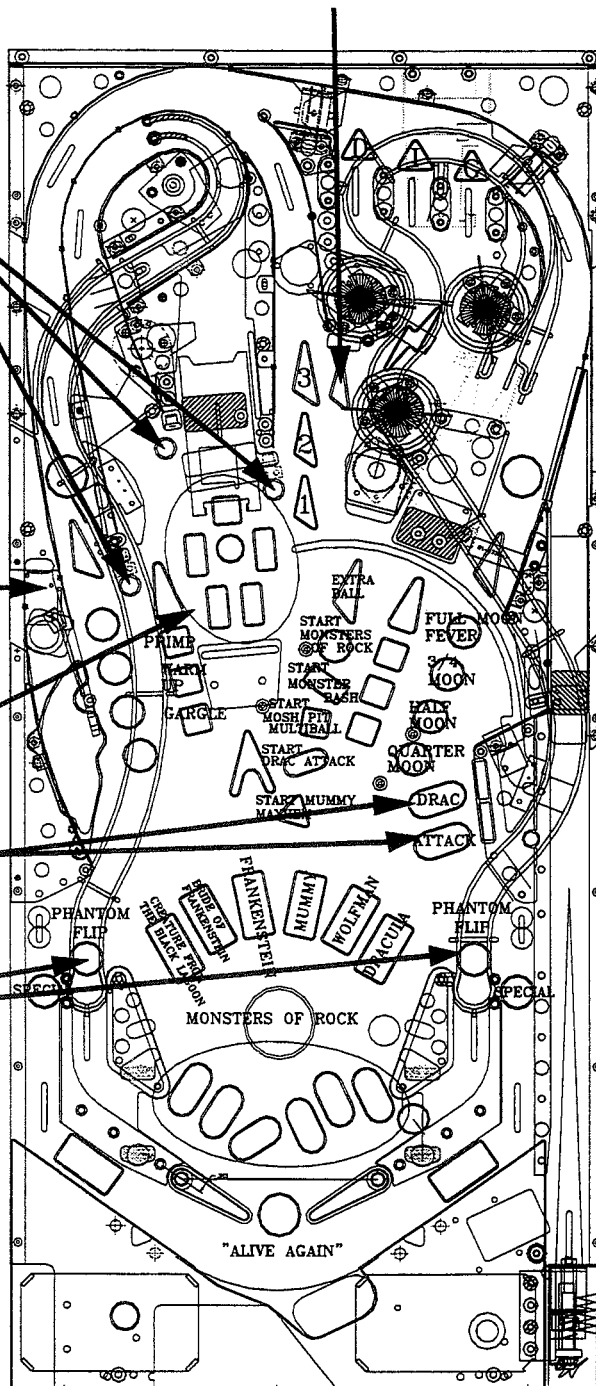

SECTION ONE

GAME OPERATION AND TEST INFORMATION

(System WPC) ROM SUMMARY

IC	TYPE	BOARD	LOCATION	PART NUMBER
Game 1	EPROM 27c080	CPU	G11	A-5343-50065-1
Security Chip	PIC16C57	CPU	G10	A-5400-50065-1
Music/Speech	EPROM 27c040	Audio	SU2	A-5343-50065-S2
Music/Speech	Masked ROM	Audio	SU3	5341-15931-SU3
Music/Speech	Masked ROM	Audio	SU4	5341-15931-SU4
Music/Speech	Masked ROM	Audio	SU5	5341-15931-SU5
Music/Speech	Masked ROM	Audio	SU6	5341-15931-SU6
Music/Speech	Masked ROM	Audio	SU7	5341-15931-SU7

NOTICE

Order replacement ROMS from your authorized Williams Electronics Games, Inc. distributor. Specify (1), part number (if available); (2), ROM level (number) on label; (3) game in which ROM is used.

PINBALL GAME ASSEMBLY INSTRUCTIONS

-MONSTER BASH IS A FOUR BALL GAME-

Power: Domestic 120V @ 60Hz
Foreign 230V @ 50Hz
Japan 100V @ 50HZ

Temp: 32°F to 100° F, (0°C to 38°C)

Humidity: Not to exceed 95% relative.

Dimensions: Width: 29" approx.
Depth: 52" approx.
Height: 75" approx.

Weight: 325 lb. approx. (crated)

1. Remove all cartons, parts, and other items from the shipping container and set them aside.
2. The leg levelers and leg bolts are among the parts in the cash box. Install the leg levelers on the front and rear legs (View 1). Place the cabinet on a support and attach the rear legs using leg bolts (View 2).
3. Attach front legs using leg bolts (View 2).

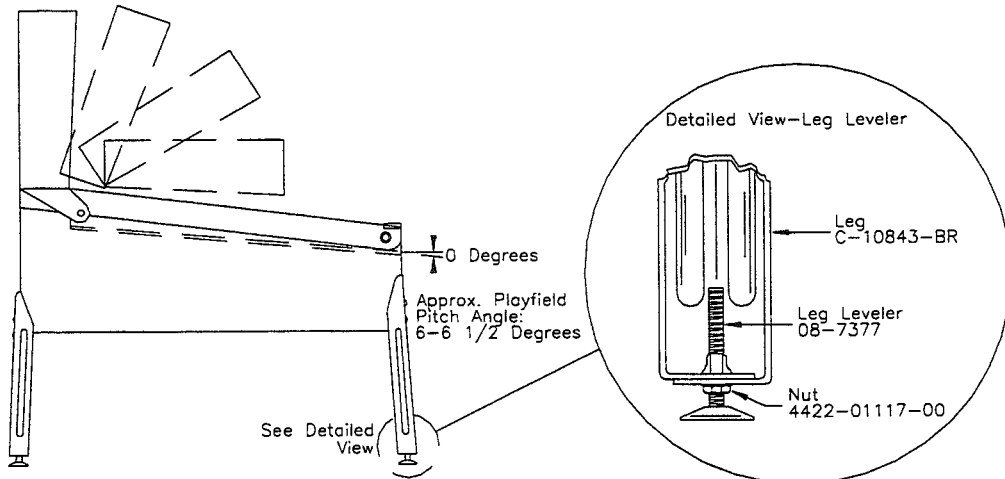

VIEW 1

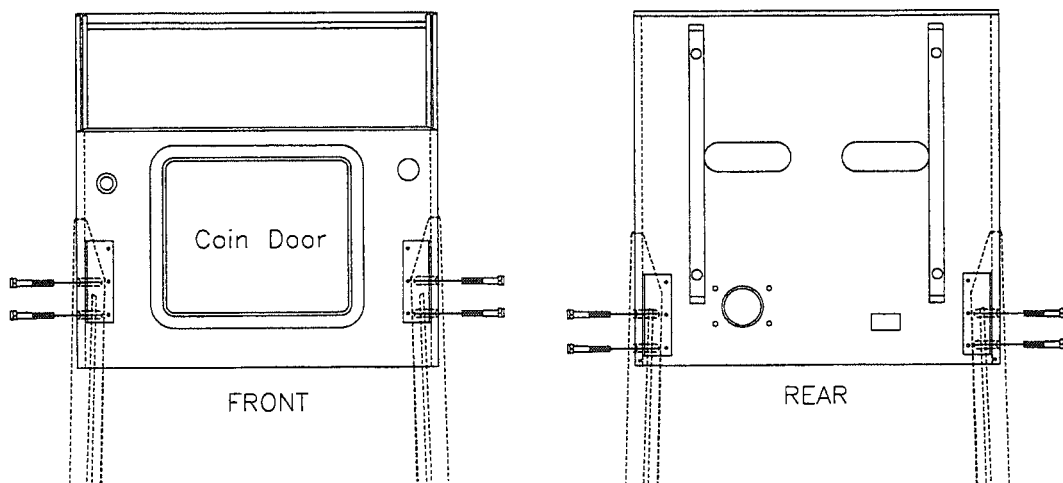

VIEW 2

4. Reach into the cabinet and backbox and ensure that the interconnecting cables are not kinked or pinched. Be careful to avoid damaging wires at any stage of the assembly process.
5. Raise the hinged backbox upright and latch it into position. Unlock the backbox. Carefully, lift the backglass/insert panel from the bottom. Slide it down and out of the backbox grooves. Rotate it forwards from the top, and lay it facedown on the playfield glass. Unplug the cables extending from the backbox to the backglass/insert panel. Set the backglass/insert panel aside.

Lift the speaker panel so that the top notches clear the top set of pins in the sides of the backbox. Rotate it forwards from the top, and lay it facedown on the playfield glass. The bottom of the speaker panel remains attached to the backbox.

Once the backglass/insert panel is removed and the speaker panel is lowered onto the playfield, the holes needed to secure the backbox upright are accessible. To secure the backbox, install the washer-head mounting bolts through the holes in the bottom of the backbox. Be sure that the bolts extend into the threaded fasteners in the cabinet.

Note: You have the option of removing the speaker panel completely. Lay the speaker panel on the playfield glass. Unplug the display cable, speaker cable, and the ground strap. Line up the bottom notches in the speaker panel with the bottom pins in the sides of the backbox. Lower the speaker panel through the notches and slide it under the backbox pins.

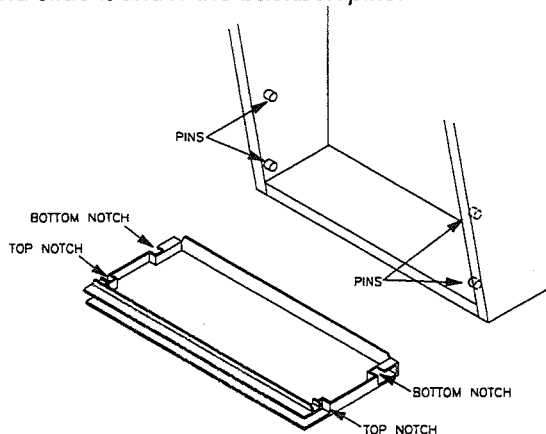

6. After the washer-head mounting bolts are installed, replace the speaker panel and the backglass/insert panel. Take care when plugging in the connectors. Connectors should plug in easily. Do not force the connectors.

⚠ CAUTION

FAILURE TO INSTALL the backbox mounting hardware properly can cause personal injury. **NEVER TRANSPORT** a pinball game with the hinged backbox erect. Always lower the backbox forward onto the playfield cabinet on a layer of protective material to prevent marring or damage and possible personal injury.

7. Extend each leg leveler *slightly* below the leg bottom, so that all four leg leveler pads are extended about the same distance. Remove the cabinet from its support and place it on the floor.

- Unlock and open the coin door. Move the lever guide toward the left side of the game, and lift the front molding off of the playfield cover glass. Slide the lever guide to the right, and close the coin door. Carefully slide the glass downward, until it clears the grooves of the left and right side moldings. Lift the glass up and away from the game, storing it carefully to avoid breakage.

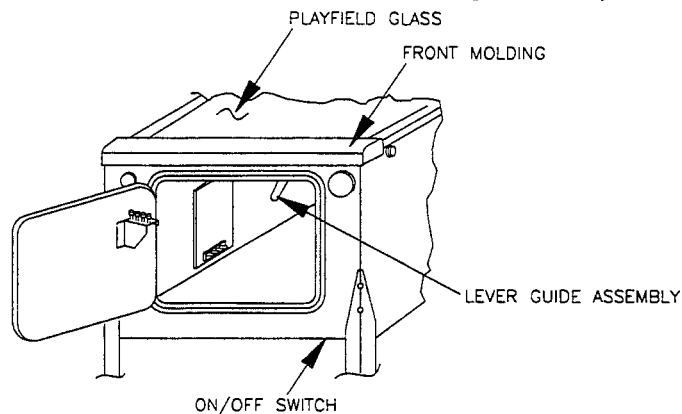

- Place a level or an inclinometer on the playfield surface. Adjust the leg levelers for proper playfield level (side-to-side).

Note: This measurement must be made *ON* the playfield, not the cabinet or the playfield cover glass. Tighten the nut on each leg leveler shaft to maintain this setting.

- The TRU-PITCH™ level is located on the right shooter rail. This allows the playfield pitch angle to be properly adjusted **WITHOUT REMOVING THE GLASS**. The first line (closest to the front of the game) on the level is approximately 6 degrees. Every line thereafter is approximately another 1/2 degree of pitch. The recommended pitch is 6-1/2 degrees. The **NOSE** of the bubble should be between the first and second line on the level (see diagram below).

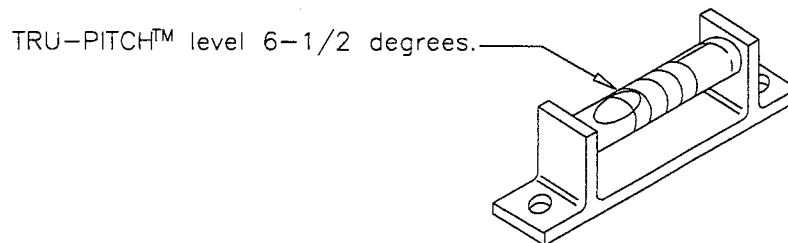

IMPORTANT!

Playfield pitch angle can affect the operation of the plumb bob tilt. The plumb bob weight is among the parts in the cash box; the operator should install the weight and adjust this tilt mechanism for proper operation, after completion of the desired playfield pitch angle setting. The unit is factory installed for a 6-1/2 degree angle. If an adjustment is necessary, loosen the screw at the bottom of the unit. Move the pointer, one groove at a time to the left or the right, depending on the degree desired. Hold the pointer in place and tighten screw

- Be sure the **required number** of balls is installed. The **MONSTER BASH** game uses **FOUR** balls.

12. Install full playfield Mylar, if desired.

Note: The **MONSTER BASH** playfield is coated with a special hardcoat surface and does not require a protective Mylar. However, mylars can be purchased through your local Williams Distributor.

13. Clean and reinstall the playfield cover glass. Replace and lock the front molding.

14. To attach the line cord, remove the four Phillips-head screws that mount to line cord cover plate to the rear cabinet. Match the prongs on the plug with the holes in the receptacle, and push the line cord securely into place. Make sure the cord is aligned with the indentation on the cover plate (indentation should point toward bottom of the cabinet). Remount line cord cover plate. If desired, four tamper resistant screws have been provided, in the unique parts bag, to remount cover plate.

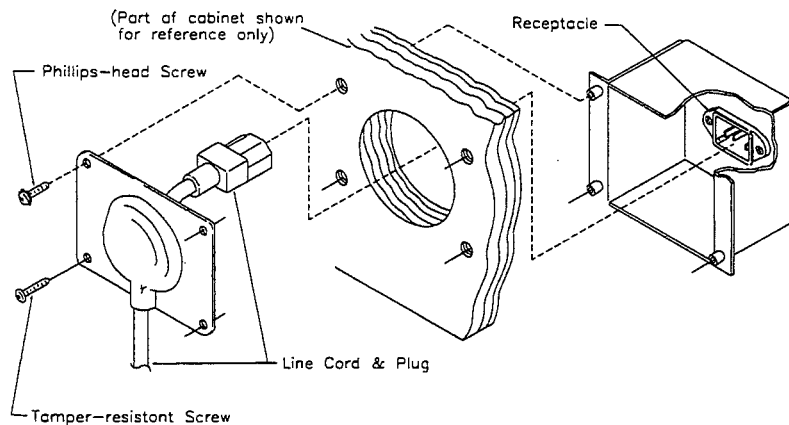

15. Move the game into the desired location. Adjust the leg levelers so that the playfield pitch is the recommended 6-1/2 degrees. This places the game in a FIXED position.

16. If a padlock is desired, install the security bar as shown below.

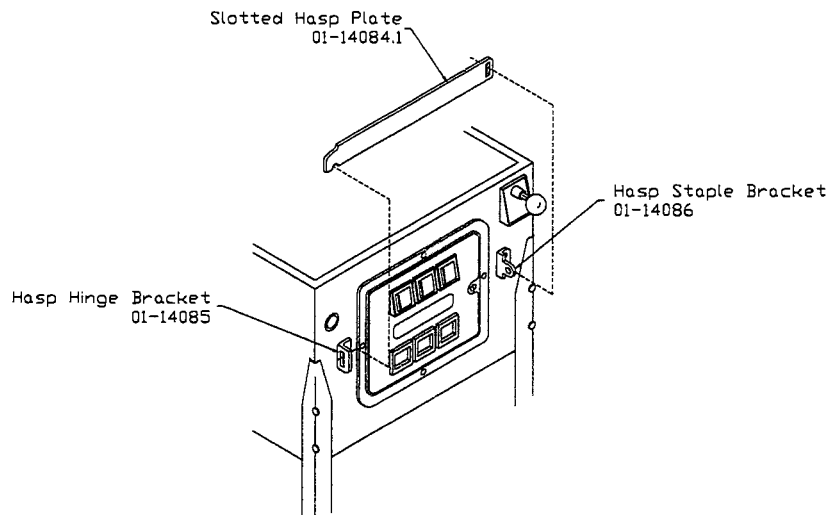

17. **IMPORTANT:** Fill out and return the registration card.

GAME CONTROL LOCATIONS

MONSTER BASH features a coin door display. When the coin door is open (in Attract mode and game play), the display shows that the high-power has been disabled. It also shows the Test Report (if there is anything to report), and some game specific information. Use the flipper buttons to page through this information.

Cabinet Switches

The On-Off Switch is on the bottom of the cabinet near the right front leg.

The Start Button is a push-button to the left of the coin door on the cabinet exterior. Press the Start button to begin a game, or during the diagnostic mode, to ask for HELP.

Coin Door Buttons

The operator controls all game adjustments, obtains bookkeeping information, and diagnoses problems, using only four push-button switches mounted on the inside of the coin door. The coin door buttons have two modes of operation Normal Function and Test Function.

Normal Function

The Service Credits button puts credits on the games that are not included in any of the game audits.

The Volume Up (+) button raises the sound level of the game. Press and hold the button until the desired level is reached.

The Volume Down (-) button lowers the sound level of the game. Press and hold the button until the desired level is reached. See Adjustment A.1 28 to turn sound off completely.

The Begin Test button starts the Menu System operation and changes the coin door buttons from Normal Function to Test Function.

Test Function

The Escape button allows you to get out of a menu selection or return to the Attract mode.

The Up (+) button allows you to cycle forward through the menu selections or adjustment choices.

The Down (-) button allows you to cycle backward through the menu selections or adjustment choices.

The *Enter button allows you to get into a menu selection or lock in an adjustment choice.

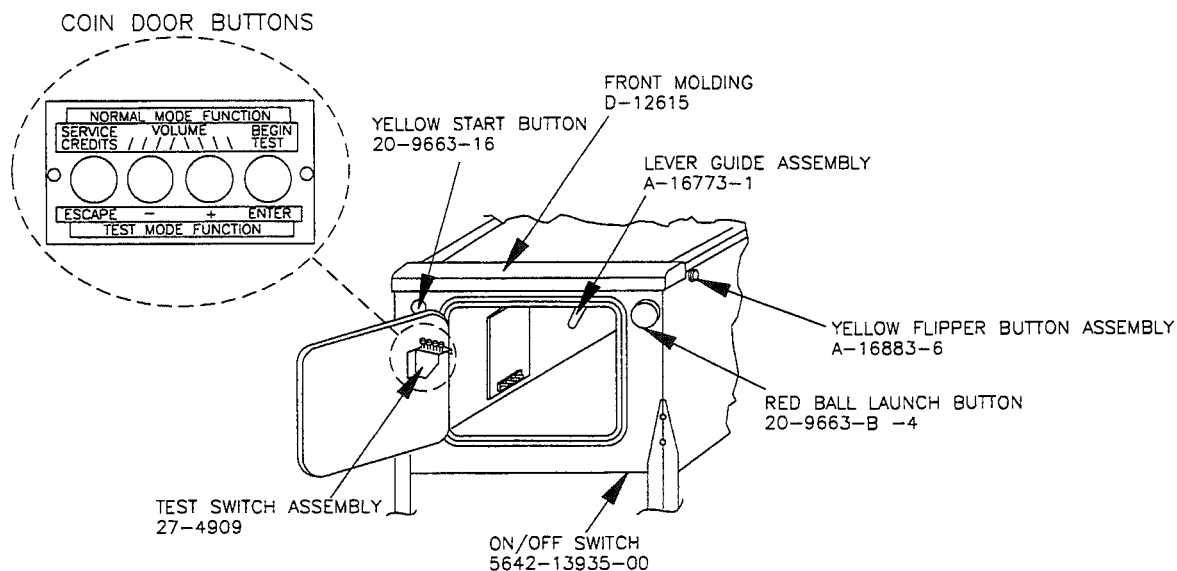

****To reset High Score, hold down the Begin Test/Enter switch for five seconds while in the Attract mode.***

GAME OPERATION

CAUTION

After assembly and installation at its site location, this game must be plugged into a properly grounded outlet to prevent shock hazard, and to assure proper game operation. DO NOT use a 'cheater' plug to defeat the ground pin on the line cord. DO NOT cut off the ground pin.

POWERING UP. With the coin door closed, plug the game in, and switch it on. In normal operation, TESTING shows in the displays as the game performs Start-up tests. Once the Start-up tests have been successfully completed the last score is displayed and the game goes into the Attract mode.

Note: After the game has been on location for a time, the Start-up tests may contain messages concerning game problems. See 'Error Messages' for more detailed information regarding messages.

Open the coin door and press the Begin Test switch. The display shows the game name, number, and software revision. The message changes and the display will show the sound software revision, the revision level of the system software, and the date the software was revised.

<i>Example:</i>	MONSTER BASH	Sound Rev. 1.0A
50065	Rev. 1.0A	SY. 0.X0
		XX-XX-98

Press the Enter button to enter the Menu System (refer to the section entitled "Menu System Operation" for more information). Perform the entire Test menu routine to verify that the game is operating satisfactorily.

In order to operate the tests that use the +50V or +20V circuits, pull the top interlock switch button out. The interlock switches are located on a bracket in the coin door opening.

ATTRACT MODE*. After completing the Test menu routine, press the Escape button three times to enter the Attract mode. During the Attract mode, the display shows a series of messages informing the player of the recent highest *scores, "**custom messages", and the score to obtain a replay *award.

CREDIT POSTING. Insert coin(s). A sound is heard for each coin, the music plays for one minute, and the display shows the number of credits purchased. So long as the number of maximum allowable credits* are NOT exceeded by coin purchase or high score, credits are posted correctly.

STARTING A GAME. Press the Start button. A startup sound plays, and the credit amount shown in the display decreases by one. The display flashes 00 (until the first playfield switch is actuated), and shows ball 1. If credits are posted, additional players may enter the game by pressing the Start button once for each player, before the end of play on the first ball.

TILTS. Actuating the cabinet slam tilt switch inside the cabinet ends the current game and proceeds to the Game Over mode. With the third closure* of the plumb bob tilt switch, the player loses the remaining play of that ball, but can complete the game.

END OF A GAME. All earned scores and bonuses are awarded. If a player's final score exceeds the specified value, the player receives a designated award for achieving the current highest score. A random digit set* appears in the display. Credits* may be awarded, when the last two digits of any player's score match the random digits. Match, high score, and game over sounds are made.

GAME OVER MODE. The Game Over display shows the high scores and the game proceeds to the Attract Mode.

* - Operator-adjustable feature

RAISING THE PLAYFIELD

CAUTION

Do not raise the playfield straight up! This game uses a slide assembly to raise and lower the playfield.

Before Raising the Playfield:

Be sure there are no balls present in the ball trough or any of the other ball-holding playfield devices (i.e. poppers). Raising the playfield with balls present in these locations may cause them to come loose and damage the playfield. Use the "Empty Balls Test" to remove all of the balls from these locations.

To Raise the Playfield:

1. Grasp bottom arch and carefully lift up playfield only high enough to clear safety brackets. Rear guide legs should not hit wood guide rails, or be used to slide out playfield.

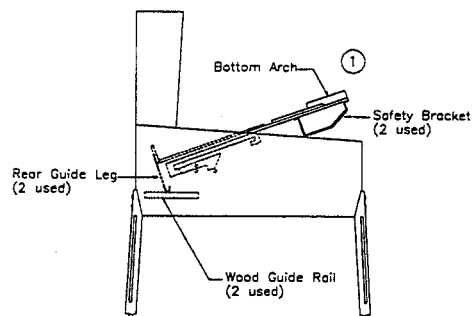

2. Pull the playfield out toward you until it stops (rest position), and raise it approximately 3".

Be sure playfield is in locked position and does not slide back into cabinet. If it does, repeat Step 2 before proceeding to Step 3.

3. Rotate playfield to upright service position (lean on backbox) by pulling toward you and up. Listen for the sound of a click: this ensures locking and pivoting sequence. The latch will engage at the upper position.

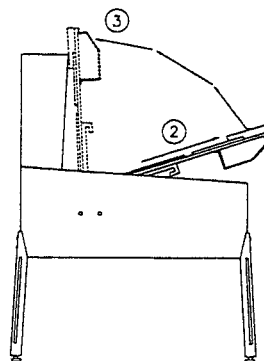

To Lower the Playfield

4. Press down on the latch end to disengage (see decal) and rotate the playfield to the rest position. This unlocks the pivoting mechanism.
5. Push the playfield back into cabinet and into the playing position.

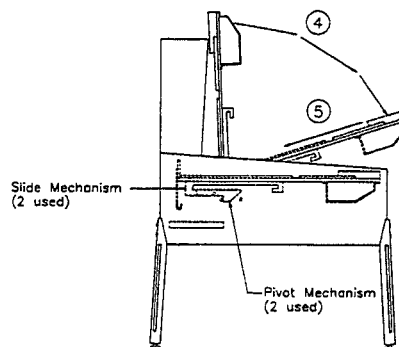

MENU SYSTEM OPERATION

The Main Menu allows you to choose from several options, which in turn lead to other menus to choose from. To access the Main Menu open the coin door, press the Begin Test button, then the Enter button. Press the Up and Down buttons to scroll through the Main Menu. To access a menu, (Bookkeeping, Printouts, etc.), from the Main Menu, press the Enter button. To return to the Main Menu (from Bookkeeping, Printouts, etc.) press the Escape button. Press the Start button for HELP.

MAIN MENU

B. BOOKKEEPING MENU

B.1 Main Audits

Press Escape

B.2 Earning Audits

To move out of a menu selection.

B.3 Standard Audits

B.4 Feature Audits

Press Enter

B.5 Histograms

To get into a menu selection.

B.6 Time-Stamps

P. PRINTOUTS MENU

P.1 Earnings Data

Press Up

Increases sequence; Example A.1, A.2, A.3, A.4.

P.2 Main Audits

P.3 Standard Audits

Press Down

P.4 Feature Audits

Decreases sequence; Example A.4, A.3, A.2, A.1.

P.5 Score Histograms

P.6 Time Histograms

Use Up or Down to cycle through the selections in a menu.

P.7 Time-Stamps

P.8 All Data

T. TEST MENU

T.1 Switch Edges Test

Use Escape and Enter to move into and out of the selected menu.

T.2 Switch Levels Test

T.3 Single Switches Test

T.4 Solenoid Test

T.5 Flasher Test

T.6 General Illumination Test

T.7 Sound and Music Test

T.8 Single Lamp Test

T.9 All Lamps Test

T.10 Lamp and Flasher Test

T.11 Display Test

T.12 Flipper Coil Test

T.13 Ordered Lamps Test

T.14 Lamp Row-Col.

T.15 DIP Switch Test

T.16 Loop/Gate Test

T.17 Up/Down Bank Test

T.18 Frankenstein Table Test

T.19 Dracula Test

T.20 Empty Balls Test

U. UTILITIES MENU

U.1 Clear Audits

U.2 Clear Coins

U.3 Reset H.S.T.D.

U.4 Set Time and Date

U.5 Custom Message

U.6 Set Game I.D.

U.7 Factory Adjustments

U.8 Factory Resets

U.9 Presets

U.10 Clear Credits

U.11 Auto Burn-in

U.12 Reset Phantom Flip Data

A. ADJUSTMENT MENU

A.1 Standard Adjustments

A.2 Feature Adjustments

A.3 Pricing Adjustments

A.4 H.S.T.D. Adjustments

A.5 Printer Adjustments

Press the Up or Down buttons to scroll through the Bookkeeping menu. Press the Enter button to access an audit menu. Press the Escape button to return to the Bookkeeping Menu.

B. BOOKKEEPING MENU

- B.1 Main Audits**
- B.2 Earning Audits**
- B.3 Standard Audits**
- B.4 Feature Audits**
- B.5 Histograms**
- B.6 Time-Stamps**

Using the One Button Audit System. The Bookkeeping Menu is obtainable directly from the Attract Mode. Repeatedly pressing the Enter button, while in the Attract Mode, will cycle through all of the game audits.

B.1 MAIN AUDITS

B.1	01	Total Earnings	00	B.1	06	Total Plays	00
B.1	02	Recent Earnings	00	B.1	07	Replay Awards	00
B.1	03	Free Play Percent	00	B.1	08	Percent Replays	00
B.1	04	Average Ball Time	00	B.1	09	Extra Balls	00
B.1	05	Time Per Credit	00	B.1	10	Percent Extra Ball	00

B.2 EARNING AUDITS

B.2	01	Recent Earnings	00	B.2	08	Total Earnings*	00
B.2	02	Recent Left Slot	00	B.2	09	Total Left Slot*	00
B.2	03	Recent Center Slot	00	B.2	10	Total Center Slot*	00
B.2	04	Recent Right Slot	00	B.2	11	Total Right Slot*	00
B.2	05	Recent 4th Slot	00	B.2	12	Total 4th Slot*	00
B.2	06	Recent Paid Credits	00	B.2	13	Total Paid Credits*	00
B.2	07	Recent Service Credits	00	B.2	14	Total Service Credits*	00

*These audits are NOT re-settable. They are a record of the earnings of the game since the "CLOCK 1ST SET" Time-stamp.

B.3 STANDARD AUDITS

B.3	01	Games Started	00	B.3	21	Play Time	00
B.3	02	Total Plays**	00	B.3	22	Minutes On	00
B.3	03	Total Free Play	00	B.3	23	Balls Played	00
B.3	04	Free Play Percent	00	B.3	24	Tilts	00
B.3	05	Replay Awards	00	B.3	25	Replay 1 Awards	00
B.3	06	Percent Replays	00	B.3	26	Replay 2 Awards	00
B.3	09	Match Awards	00	B.3	27	Replay 3 Awards	00
B.3	10	Percent Match	00	B.3	28	Replay 4 Awards	00
B.3	11	H.S.T.D. Credits	00	B.3	29	1 Player Games	00
B.3	12	Percent H.S.T.D.	00	B.3	30	2 Player Games	00
B.3	13	Extra Ball	00	B.3	31	3 Player Games	00
B.3	14	Percent Extra Ball	00	B.3	32	4 Player Games	00
B.3	15	Tickets Awarded	00	B.3	33	H.S.T.D. Reset Count	00
B.3	16	Percent Tickets	00	B.3	34	Burn-in Time†	00:00:00
B.3	17	Left Drains	00	B.3	35	1st Replay Level	00
B.3	18	Right Drains	00	B.3	36	Left Flipper	00
B.3	19	Average Ball Time	00	B.3	37	Right Flipper	00
B.3	20	Average Game Time	00				

**Total Plays* only counts on completed games. A game is considered complete when the final ball begins. Audit information from incomplete games is ignored. Operation for test and service do not affect audits. †This Audit cannot be reset.

B.4 FEATURE AUDITS

B.4 01 Ball Saves	00%	00
The number of times the ball was saved.		
B.4 02 Total Multiballs	00%	00
The number of times a Multiball Feature was started.		
B.4 03 Creature Started	00%	00
The number of times Creature Feature was started.		
B.4 04 Creature Completed	00%	00
The number of times Creature Feature was completed.		
B.4 05 Ball and Chain Started	00%	00
The number of times Ball and Chain was started.		
B.4 06 Ball and Chain Completed	00%	00
The number of times Ball and Chain was completed.		
B.4 07 Frankenstein Multiball Started	00%	00
The number of times Frankenstein Multiball was started.		
B.4 08 Frankenstein Multiball Completed	00%	00
The number of times Frankenstein Multiball was completed.		
B.4 09 Mummy Mayhem Lit	00%	00
The number of times Mummy Mayhem was lit.		
B.4 10 Mummy Mayhem Started	00%	00
The number of times Mummy Mayhem was started.		
B.4 11 Mummy Mayhem Completed	00%	00
The number of times Mummy Mayhem was completed.		
B.4 12 Full Moon Fever Started	00%	00
The number of times Full Moon Fever was started.		
B.4 13 Full Moon Fever Completed	00%	00
The number of times Full Moon Fever was completed.		
B.4 14 Drac-Attack Lit	00%	00
The number of times Drac-Attack was lit.		
B.4 15 Drac-Attack Started	00%	00
The number of times Drac-Attack was started.		
B.4 16 Drac-Attack Completed	00%	00
The number of times Drac-Attack was completed.		
B.4 17 Monsters Extra Ball Lit	00%	00
The number of Extra Balls lit from collecting Monsters.		
B.4 18 Instrument Special Lit	00%	00
The number of Specials lit from collecting Instruments.		
B.4 19 Monster Bash Started	00%	00
The number of times Monster Bash was started.		

Feature Audits Continued...

B.4 20 Monsters of Rock Started	00%	00
The number of times Monster of Rock was started.		
B.4 21 Rock 3X Awards	00%	00
The number of times a 3X award was given during Monsters of Rock.		
B.4 22 Rock 5X Awards	00%	00
The number of times a 5X award was given during Monsters of Rock.		
B.4 23 Rock 7X Awards	00%	00
The number of times a 7X award was given during Monsters of Rock.		
B.4 24 Rock 10X Awards	00%	00
The number of times a 10X award was given during Monsters of Rock.		
B.4 25 Random Awards	00%	00
The number of Random Awards (Concert Halls) given.		
B.4 26 Random Award Extra Ball Lit	00%	00
The number of Extra Balls lit from the Random Award (Concert Halls).		
B.4 27 Mosh Pit Multiball Started	00%	00
The number of times Mosh Pit Multiball was started.		
B.4 28 Center Loop Extra Ball Lit	00%	00
The number of Extra Balls lit from the Center Loop.		
B.4 29 Lament Started	00%	00
The number of times Lament was started.		

B.5 HISTOGRAMS

B.5 01	0 to 1 Million Scores	00%	00
B.5 02	1 Million to 2 Million Scores	00%	00
B.5 03	2 Million to 3 Million Scores	00%	00
B.5 04	3 Million to 4 Million Scores	00%	00
B.5 05	4 Million to 5 Million Scores	00%	00
B.5 06	5 Million to 6 Million Scores	00%	00
B.5 07	6 Million to 12 Million Scores	00%	00
B.5 08	12 Million to 18 Million Scores	00%	00
B.5 09	18 Million to 25 Million Scores	00%	00
B.5 10	25 Million to 50 Million Scores	00%	00
B.5 11	50 Million to 75 Million Scores	00%	00
B.5 12	75 Million to 99 Million Scores	00%	00
B.5 13	Over 99 Million Scores	00%	00
B.5 14	Game Time 0.0 to 1.0 Minute	00%	00
B.5 15	Game Time 1.0 Minute to 1.5 Minutes	00%	00
B.5 16	Game Time 1.5 Minutes to 2.0 Minutes	00%	00
B.5 17	Game Time 2.0 Minutes to 2.5 Minutes	00%	00
B.5 18	Game Time 2.5 Minutes to 3.0 Minutes	00%	00
B.5 19	Game Time 3.0 Minutes to 3.5 Minutes	00%	00
B.5 20	Game Time 3.5 Minutes to 4.0 Minutes	00%	00
B.5 21	Game Time 4 Minutes to 5 Minutes	00%	00
B.5 22	Game Time 5 Minutes to 6 Minutes	00%	00
B.5 23	Game Time 6 Minutes to 8 Minutes	00%	00
B.5 24	Game Time 8 Minutes to 10 Minutes	00%	00
B.5 25	Game Time 10 Minutes to 15 Minutes	00%	00
B.5 26	Game Time Over 15 Minutes	00%	00

B.6 TIME-STAMPS

B.6 01	Current Time
B.6 02	Clock 1st Set
B.6 03	Clock Last Set
B.6 04	Audits Cleared
B.6 05	Coins Cleared
B.6 06	Factory Setting
B.6 07	Last Game Start
B.6 08	Last Replay
B.6 09	Last H.S.T.D. Reset
B.6 10	Champion Reset
B.6 11	Last Printout
B.6 12	Last Service Credit

Time-Stamps Menu allows you to view dates and times that are important to game software.

Press the Up or Down buttons to scroll through the Printouts menu. Press the Enter button to access a menu. Press the Escape button to return to the Printouts Menu.

P. PRINTOUTS MENU

(An optional board is required to use the Printouts feature.)

- P.1 Earnings Data**
- P.2 Main Audits**
- P.3 Standard Audits**
- P.4 Feature Audits**
- P.5 Score Histograms**
- P.6 Time Histograms**
- P.7 Time-Stamps**
- P.8 All Data**

The Printouts Menu is a combination of the other menus. This menu allows you to access and print information in the available menu selections.

If no printer is attached the message "Waiting for Printer" appears in the displays. **Note:** *Set the print specification from the Adjustment Menu, A.5 Printer Adjustments.*

Press the Up or Down buttons to scroll through the Test menu. Press the Enter button to access a test. Press the Escape button to return to the Test menu. During any test, press the Start button to obtain the wire color, driver number, connector number and fuse location.

T. TEST MENU

T.1	Switch Edges Test	T.11	Display Test
T.2	Switch Levels Test	T.12	Flipper Coil Test
T.3	Single Switch Test	T.13	Ordered Lamps Test
T.4	Solenoid Test	T.14	Lamp Row-Col.
T.5	Flasher Test	T.15	DIP Switch Test
T.6	General Illumination Test	T.16	Loop /Gate Test
T.7	Sound & Music Test	T.17	Up/Down Bank Test
T.8	Single Lamps Test	T.18	Frankenstein Table Test
T.9	All Lamps Test	T.19	Dracula Test
T.10	Lamps And Flasher Test	T.20	Empty Balls Test

In order to operate the tests that use the +50V or +20V circuits, pull the top interlock switch button out. The interlock switches are located on a bracket just inside the coin door opening.

The switch matrix, on the left side of the display, shows the state of all switches. A dot indicates the switch is open, a square indicates the switch is closed. The numbers assigned to each switch indicate where the switch is located in the matrix. The number on the left indicates the column, the number on the right indicates the row. Example - Switch 23 is 2nd column, 3rd row.

A short to ground - on either the row or column wire - appears as a shorted row(s). However, a column wire shorted to ground disappears when all of the indicated row switches are open. A row wire shorted to ground does not disappear.

A shorted diode in the switch matrix can cause other switches to appear closed. These "phantom" switches (though not actually closed), complete a rectangle in the switch matrix. Therefore, if two switches in the same column are closed (example; #22 and #24), and a third switch is pressed in another column but in the same row as one of the first two (example; #32), the "phantom" switch #34 is falsely indicated as closed. The switch with the shorted diode is diagonally opposite the "phantom" switch (in this case #22).

T.1 SWITCH EDGES TEST

Press each of the switches one at a time. The name and number of the switch is shown in the display. If a switch other than the one pressed, or no switch at all is indicated, the system has detected a problem with the switch circuit. To return the Test menu, press the Escape button.

T.2 SWITCH LEVELS TEST

This test automatically cycles through all switches that are detected closed. The name and number of each switch that is detected is shown in the display. A filled square indicates the switch's position in the matrix. To return the Test menu, press the Escape button.

T.3 SINGLE SWITCHES TEST

This test isolates a single switch and shows its state in the display. A mechanical switch is 'made' when the display reads closed. An opto switch is 'made' (opto beam broken) when the display reads open. Use the Up or Down buttons to select the switch to be tested. To return the Test menu, press the Escape button.

T.4 SOLENOID TEST

The Solenoid test has three modes -- Repeat, Stop, and Run. Only one solenoid should pulse at a time. The system has detected a problem if more than one solenoid pulses, a solenoid comes on and stays on, or no solenoids pulse during the Repeat and Run modes.

Repeat: The Repeat mode pulses an individual solenoid. Press the Enter button to start this test. The name of the first solenoid shows in the display and the corresponding coil pulses. Press the Up or Down buttons to cycle through the solenoids, one at a time. The same solenoid pulses until you press the Up or Down buttons to advance to the next one. To return the Test menu, press the Escape button. To advance to the next test mode, press the Enter button.

Stop: The Stop mode halts the Solenoid test. No solenoids should be active. To return the Test menu, press the Escape button. To advance to the next test mode, press the Enter button.

Run: The Run mode cycles through the solenoids automatically. The display shows the name and number of the solenoid currently being pulsed. To return the Test menu, press the Escape button. To return to the Repeat mode, press the Enter button.

T.5 FLASHER TEST

This tests the flashlamp part of the solenoid circuit. There are three modes -- Repeat, Stop, and Run. During this test the flashlamp circuit named in the display should blink. The system has detected a problem if more than one flashlamp circuit blinks, the lamps stays on, or no lamps blink during the Repeat and Run modes.

Repeat: The Repeat mode pulses an individual flashlamp. Press the Enter button to start this test. The name and number of the first flashlamp is displayed and the corresponding bulb(s) blinks. The same bulb(s) blinks until you press the Up or Down buttons to advance to the next one. To return to the Test menu, press the Escape button. To advance to the next test mode, press the Enter button.

Stop: The Stop mode halts the Flasher test. There should not be any flashlamps lit during this mode. To return to the Test menu, press the Escape button. To advance to the next test mode, press the Enter button.

Run: The Run mode cycles through the flashlamps automatically. The display shows the name and number of the flashlamp circuit currently being pulsed as the corresponding bulb(s) flashes. To return to the Test menu, press the Escape button. To return to the Repeat mode, press the Enter button.

T.6 GENERAL ILLUMINATION TEST

This test checks all of the General Illumination circuits. There are two modes of operation -- Stop and Run.

Note: General Illumination strings four & five do not brighten or dim, they are always ON.

Stop: The Stop mode allows you to cycle through the General Illumination test manually. Press the Up or Down buttons to advance through the test. All illumination is tested first, followed by an individual circuit test. The circuit name and number shows in the display while the corresponding bulbs light. If any other results occur the system has detected an error. To return to the Test menu, press the Escape button. To advance to the next test mode, press the Enter button.

T.6 General Illumination Test Continued...

Run: The Run mode cycles through the General Illumination test automatically. For each circuit shown in the display the corresponding bulbs should light. If any other results occur, the system has detected a problem. To return to the Test menu, press the Escape button. To return to the Stop mode, press the Enter button.

T.7 SOUND AND MUSIC TEST

The Sound and Music test checks the audio circuits. This test has three modes for testing the sound and music circuits -- Run, Repeat, and Stop.

Run: The Run mode steps through a sequence of sounds and music. Press the Up or Down buttons to advance to a particular sound or tune. A sound or tune should be heard for each name and number that appears in the display. Any other results indicate the system has detected a problem. To return to the Test menu, press the Escape button. To advance to the next test mode, press the Enter button.

Repeat: The Repeat mode causes the program to stop and repeat a particular sound/tune. The same sound repeats continuously until you press the Up or Down buttons to advance to the next one. Any other results indicates the system has detected a problem. To return to the Test menu, press the Escape button. To advance to the next test mode, press the Enter button.

Stop: The Stop mode stops this test altogether. Nothing should be heard. Any other results indicate the system has detected a problem. To return to the Test menu, press the Escape button. To return to the Run mode, press the Enter button.

T.8 SINGLE LAMP TEST

The number assigned to each lamp indicates the lamp's position in the matrix. The number on the left indicates the column. The number on the right indicates the row. Example - Lamp 23 means 2nd column, 3rd row.

The Single Lamp test checks each lamp circuit individually. Press the Up or Down buttons to scroll through this test. A lamp should light for each name and number that is displayed. Any other results indicate the system has detected a problem. To return to the Test menu, press the Escape button.

T.9 ALL LAMPS TEST

This test causes all the controlled lamps to flash at the same time. Every controlled lamp should flash. Any other results indicate the system has detected a problem. To return to the Test menu, press the Escape button.

T.10 LAMP AND FLASHER TEST

This test causes all the flashlamps and the controlled lamps to flash at the same time. The controlled lamps blink, while the flashlamps cycle from highest to lowest. Any other results indicate the system has detected a problem. To return to the Test menu, press the Escape button.

T.11 DISPLAY TEST

This test automatically checks every dot in the Dot Matrix Display board. A series of patterns appear in sequence. Each pattern turns on and off a section of dots. Every dot on the matrix display should be turned on and off during this test. To return to the Test menu, press the Escape button.

T.12 FLIPPER COIL TEST

The Flipper Coil test has three modes -- Repeat, Stop, and Run. Only one flipper should pulse at a time. The system has detected a problem if more than one flipper pulses, a flipper comes on and stays on, or no flippers pulse during the Repeat and Run modes.

Repeat: The Repeat mode pulses an individual flipper. Press the Enter button to begin the test. Press the Up or Down buttons to cycle through the flipper coils one at a time. To return to the Test menu, press the Escape button. To advance to the next test mode, press the Enter button.

Stop: The Stop mode halts the Flipper Coil test. No coils should pulse while the test is stopped. To return to the Test menu, press the Escape button. To advance to the next test mode, press the Enter button.

Run: The Run mode cycles through the flippers automatically. The display shows the name and number of the flipper coil currently being pulsed. To return to the Test menu, press the Escape button. To return to the Repeat mode, press the Enter button.

T.13 ORDERED LAMPS TEST

The number assigned to each lamp indicates the lamp's position in the matrix. The number on the left indicates the column. The number on the right indicates the row. Example - Lamp 23 means 2nd column, 3rd row.

This test checks each lamp circuit individually. Press the Up or Down buttons to cycle through the lamps. Lamps light in a clock-wise or counter clock-wise direction starting from the bottom of the playfield. The direction depends on whether the Up or Down button is pressed. For each name and number that is shown in the display, the corresponding lamp should light. Any other results indicate the system has detected a problem. To return to the Test menu, press the Escape button.

T.14 LAMP ROW - COLUMN

This test allows individual rows and columns in the lamp matrix to be operated. This is useful for troubleshooting wiring and driver problems.

Press the Up and Down buttons to cycles through the different rows and columns. To return to the Test menu, press the Escape button.

T.15 DIP SWITCH TEST

This test is used to show the positions of the DIP switches on the CPU board (U27). To return to the Test menu, press the Escape button.

T.16 LOOP/GATE TEST

This test is used to verify proper ball delivery from the shooter lane onto the playfield, and to exercise the four loop switches and the two control gates. This test has two modes of operation:

Loops Mode: This mode is used to verify that the ball is able to pass through the control gates and around either of the loops. This is useful for clearing "Left Gate Stuck Closed" and "Right Gate Stuck Closed" errors that may appear in the test report. If an error exists, one of them will be shown on the bottom line of the display.

To verify loop switch and control gate operation in "Loops Mode", press the Up or Down buttons until the message "Test Mode: Around Loops" appears on the second line of the

T.16 Loop/Gate Test Continued...

display. Roll a ball around either of the loops (a ball may be ejected from the trough by pressing the launch button). A sound is made as the ball passes over the loop switches, and the state of the loop switches is updated in the display. If the ball is traveling around the loop from left to right, the right control gate should open upon activation of the second left loop switch (L.HI). If the ball is traveling around the loop from right to left, the left control gate should open upon activation of the second right loop switch (R.HI). When the ball has finished its path around the loop (either from left to right, or from right to left), the test should report "TEST PASSED - PRESS ENTER" on the bottom line of the display. Any other result indicates a problem with either the loop switches, or the control gates, or both. To re-test, press the Enter button.

"Left Gate Stuck Closed" errors can be cleared in "Loops Mode" by repeatedly testing the right loop (the Enter button must be pressed at the end of each test). The test will clear the error when there have been two consecutive successful right loop tests in this mode.

"Right Gate Stuck Closed" errors can be cleared in "Loops Mode" by repeatedly testing the left loop (the Enter button must be pressed at the end of each test). The test will clear the error when there have been two consecutive successful left loop tests in this mode.

Jets Mode: This mode is used to verify that the ball is able to pass into either of the loops and be diverted into the jets. This is useful for clearing "Left Gate Stuck Open" and "Right Gate Stuck Open" errors that may appear in the test report. If an error exists, one of them will be shown on the bottom line of the display.

To verify loop switch and control gate operation in "Jets Mode", press the Up or Down buttons until the message "Test Mode: To Jet Bumpers" appears on the second line of the display. Roll a ball into either of the loops (a ball may be ejected from the trough by pressing the launch button). A sound is made as the ball passes over the loop switches, and the state of the loop switches is updated in the display. If the ball is traveling to the jets from left to right, the right control gate should remain closed upon activation of either of the left loop switches (L.LO and L.HI). If the ball is traveling to the jets from right to left, the left control gate should remain closed upon activation of either of the right loop switches (R.LO and R.HI). When the ball has finished its path into the jets (either from the left, or from the right), and makes contact with one of the top lane switches, the test should report "TEST PASSED - PRESS ENTER" on the bottom line of the display. Any other result indicates a problem with either the loop switches, or the control gates, or both. To re-test, press the Enter button.

"Left Gate Stuck Open" errors can be cleared in "Jets Mode" by repeatedly testing the right loop (the Enter button must be pressed at the end of each test). The test will clear the error when there have been two consecutive successful right loop tests in this mode.

"Right Gate Stuck Open" errors can be cleared in "Jets Mode" by repeatedly testing the left loop (the Enter button must be pressed at the end of each test). The test will clear the error when there have been two consecutive successful left loop tests in this mode.

Ball delivery from the shooter lane can be verified by this test in either "Loops Mode" or "Jets Mode" by placing a ball into the shooter lane, and pressing the launch button. When in "Loops Mode", the ball should travel all the way around the loop, and be delivered cleanly to the left flipper. When in "Jets Mode", the ball should be delivered into the loop, through one of the top lane switches, and into the jet bumpers.

During this test, the diagnostic test buttons inside the coin door act as follows:

Escape: This button returns to the previous menu.

Down/Up: These buttons toggle the test mode between "Loops Mode" and "Jets Mode".

Enter: This button is used to clear the "TEST PASSED/TEST FAILED" messages.

T.17 UP/DOWN BANK TEST

This test is used to verify proper operation of the Up/Down Target Bank. It exercises the Up/Down Bank motor, and the Up/Down Bank position switches.

Upon entry, this test will attempt to position the Frankenstein Table, if necessary. The Up/Down Bank can only operate with the Frankenstein Table in the UP position. If, at the start of the test, the Frankenstein Table is unable to be put in its UP position, the message "CAN'T POSITION FRANK. TABLE" will appear on the bottom line of the display, and the test will not run. It will then be necessary to fix the Frankenstein Table.

Once the Frankenstein Table has been positioned, the Up/Down Bank test will run automatically. The test continually moves the Bank to the Up and Down positions, with small pauses when a new position is reached. To stop the Up/Down Bank motor from moving during this test, press the Enter button. To re-start the Up/Down Bank motor, press the Enter button again.

This test is useful for clearing Up/Down Bank UP and Up/Down Bank DOWN switch errors that may appear in the test report. If the errors exist, they will be shown on the bottom line of the display. The errors are cleared when the Up/Down Bank completes two consecutive successful cycles.

During this test, the diagnostic test buttons inside the coin door act as follows:

Escape: This button returns to the previous menu.

Enter: This button toggles the state of the test from Running to Stopped, and from Stopped to Running.

T.18 FRANKENSTEIN TABLE TEST

This test is used to verify proper operation of the Frankenstein Table. It exercises the Frankenstein Table motor, and the Frankenstein Table position switches.

Upon entry, this test will attempt to position the Up/Down Target Bank, if necessary. The Frankenstein Table can only operate with the Up/Down Bank in the DOWN position. If, at the start of the test, the Up/Down Bank is unable to be put in its DOWN position, the message "CAN'T POSITION UP/DOWN BANK" will appear on the bottom line of the display, and the test will not run. It will then be necessary to fix the Up/Down Bank.

Once the Up/Down Bank has been positioned, the Frankenstein Table test will run automatically. The test continually moves the Table to the Up and Down positions, with small pauses when a new position is reached. To stop the Frankenstein Table motor from moving during this test, press the Enter button. To re-start the Frankenstein Table motor, press the Enter button again.

This test is useful for clearing Frankenstein Table UP and Frankenstein Table DOWN switch errors that may appear in the test report. If the errors exist, they will be shown on the bottom line of the display. The errors are cleared when the Frankenstein Table completes two consecutive successful cycles.

During this test, the diagnostic test buttons inside the coin door act as follows:

Escape: This button returns to the previous menu.

Enter: This button toggles the state of the test from Running to Stopped, and from Stopped to Running.

T.19 DRACULA TEST

This test is used to verify proper operation of the Dracula mechanism. It exercises the Dracula motor, and the Dracula position switches.

This test has two modes of operation:

T.19 Dracula Test Continued...

Manual Mode: This mode provides user control of the movement of the Dracula mechanism. The Down button is used to move the mechanism to the left, and the Up button is used to move the mechanism to the right.

Automatic Mode: This mode moves the mechanism automatically. The mechanism will first return to its HOME position (position #1), and then move to positions 2, 3, 4, 5, 4, 3, 2, and back to HOME (position #1), with small pauses when a new position is reached.

The speed of the motor can be set by pressing the Enter button until the message "Test Mode: Set Speed" appears on the second line of the display. To decrease the speed of the mechanism during the test, press the Down button. To increase the speed of the mechanism during the test, press the Up button.

This test is useful for clearing Dracula position switch errors that may appear in the test report. If errors exist, they will be shown on the bottom line of the display. The error for a bad position switch is cleared when the Dracula mechanism completes two consecutive successful moves to the position.

During this test, the diagnostic test buttons inside the coin door act as follows:

Escape: This button returns to the previous menu.

Down: In Manual Mode, this button moves the Dracula mechanism to the left. When in Set Speed Mode, this button decreases the speed of the mechanism.

Up: When in Manual Mode, this button moves the Dracula mechanism to the right. When in Set Speed Mode, this button increases the speed of the mechanism.

Enter: This button is used to change the test modes.

T.20 EMPTY BALLS TEST

This test kicks out all balls loaded in troughs, lockups, poppers, and kick-outs until no balls remain in those locations.

Note: *As the trough kicks out balls, they will stack up in the shooter groove, which may require manual clearing in order to allow further balls to be kicked out.*

To scroll through the Utilities menu, press the Up or Down buttons. To access a utility, press the Enter button. To see the setting choices of a utility option, press the Up and Down buttons. Press the Enter button to lock in a choice. If you make a mistake, press Escape while "Saving Adjustment Value" is in the display. The original setting is retained and the new setting is ignored. To return to the Utilities menu, press the Escape button.

U. UTILITIES MENU

U.1	Clear Audits	U.7	Factory Adjustments
U.2	Clear Coins	U.8	Factory Reset
U.3	Reset H.S.T.D.	U.9	Preset
U.4	Set Time & Date	U.10	Clear Coins
U.5	Custom Message	U.11	Auto Burn-in
U.6	Set Game I.D.	U.12	Reset Phantom Flip Data

U.1 CLEAR AUDITS

Press the Enter button to clear the Standard Audits (except Burn-in Time), Feature Audits, and Histograms.

U.2 CLEAR COINS

Press the Enter button to clear the Earnings Audits.

U.3 RESET H.S.T.D.

Press the Enter button to clear the High Score to Date Table and the Grand Champion.

U.4 SET TIME AND DATE

Press the Enter button to activate the time and date. Use the Up or Down buttons to change the value, then press the Enter button to lock in that value. If you make a mistake press the Escape button while "Saving Adjustment Value" is displayed. The new value is ignored and the original value is retained.

U.5 CUSTOM MESSAGE *Set A.1 20 to ON before trying to write a custom message.*

Press the Enter button to begin entry of the custom message. Use the Up or Down buttons to cycle through letters. Use the Start button to cycle through punctuation marks. Press the Enter button to lock in the desired letter and punctuation. If you make a mistake, use Up and Down to select the "back-arrow" character. The "back-arrow" character is located before the space character and after the number nine. Press Enter while the back-arrow shows to erase the previously entered character. Once the message is complete, press and hold the Enter button until "Message Stored" is displayed.

Press the Escape button to cancel the new message. The message "Press Enter to Reset" appears. If Enter is pressed, the custom message is cleared and no message is displayed. If Escape is pressed, the original message remains intact.

U.6 SET GAME I.D.

This utility allows for the installation of a message, such as game location, that only appears on the printouts. Press the Enter button to activate Set Game I.D. Use the Up or Down buttons to cycle through letters. Use the Start button to cycle through punctuation marks. Press the Enter button to lock in desired letters and punctuation marks.

U.7 FACTORY ADJUSTMENT

Press the Enter button to restore the adjustments to factory settings.

U.8 FACTORY RESET

Press the Enter button to restore the adjustments to their factory setting, clear the Audits, H.S.T.D. Table, and Custom Message/Game I.D.

U.9 PRESETS

Use the Up or Down buttons to cycle through the available Presets. When the desired Preset is displayed, press the Enter button to lock in that Preset. If you make a mistake, press the Escape button while "Saving Adjustment Value" is displayed. The new value is ignored and the original value is retained.

Game Difficulty Levels The game play difficulty adjustments can be changed to a combination that is MUCH LESS to MUCH MORE difficult than Factory Settings. The Game Difficulty Setting Table lists the adjustments and settings that comprise the individual group.

U.9 01 INSTALL EXTRA EASY	MUCH LESS difficult than factory setting.
U.9 02 INSTALL EASY	Somewhat LESS difficult than factory setting.
U.9 03 INSTALL MEDIUM	Nearly the SAME as factory setting.
U.9 04 INSTALL HARD	Somewhat MORE difficult than factory setting.
U.9 05 INSTALL EXTRA HARD	MUCH MORE difficult than factory setting.

**DIFFICULTY SETTING TABLE FOR
U.S., CANADIAN, FRENCH, GERMAN, AND EUROPEAN GAMES**

Adj. #	Adj. Description	Extra Easy U.9 01	Easy U.9 02	Medium U.9 03 (factory)	Hard U.9 04	Extra Hard U.9 05
A.2 01	BALL SAVES	02	01	01	01	00
A.2 02	BALL SAVE TIME	04	03	03	03	N/A
A.2 03	EXTRA BALL PERCENT	35%	30%	30%	30%	25%
A.2 05	BALL AND CHAIN TIMER	35	35	30	25	25
A.2 06	FRANK BODY PART SPOT BALL START	YES	YES	YES	NO	NO
A.2 08	DRACULA LETTERS	3	3	3	2	0
A.2 09	DRAC-ATTACK TIMER	40	35	30	25	20
A.2 13	CENTER LOOP EXTRA BALL 1	9	12	12	12	15

U.9 06 INSTALL 5 BALL

U.9 07 INSTALL 3 BALL

Adjustments U.9 06 and U.9 07 can be used to change a game to 3 or 5 ball play, including changing of certain features to the recommended 3-and 5-ball level. The Preset Game Adjustments Table for U.S./Canadian Games lists the adjustments and settings that comprise the individual groups.

PRESET ADJUSTMENTS TABLE FOR U.S. AND CANADIAN GAMES

Adj. #	Adj. Description	Install 5-ball U.9 06	Install 3-ball U.9 07
A.1 01	BALL PER GAME	05	03
A.1 07	REPLAY START	50,000,000	30,000,000
A.2 06	FRANK BODY PART SPOT BALL START	NO	YES
A.2 08	DRACULA LETTERS	0	3
A.2 10	MONSTER EXTRA BALL	4	3
A.2 11	INSTRUMENTS SPECIAL	4	3
A.2 13	CENTER LOOP EXTRA BALL 1	15	12

U.9 08 INSTALL ADD-A-BALL

This option deletes all Free Play awards and replaces them with Extra Ball awards. Individual adjustments are affected, as follows:

Adjust.	Name	New Settings
A.1 13	Replay Boost	Off
A.1 14	Replay Award	Extra Ball
A.1 15	Special Award	Extra Ball
A.1 17	Extra Ball Ticket	No
A.1 19	Match Feature	Off
A.4 04	Champion Credits	00
A.4 05	High Score 1 Credits	00
A.4 06	High Score 2 Credits	00
A.4 07	High Score 3 Credits	00
A.4 08	High Score 4 Credits	00
A.4 16	Monster Bash Credits	00
A.4 18	Monsters of Rock Credits	00

U.9 09 INSTALL TICKET

This option deletes Credit awards and replaces them with Ticket awards. Individual adjustments are affected as follows:

Adjust.	Name	New Settings
A.1 14	Replay Award	Ticket
A.1 15	Special Award	Ticket
A.1 16	Match Award	Ticket
A.1 17	Extra Ball Ticket	Yes
A.1 31	Ticket Expansion Brd.	Yes
A.4 02	H.S.T.D. Award Ticket	Yes

U.9 10 INSTALL NOVELTY

This option removes all Free Play and Extra Ball awards. Individual adjustments are affected as follows:

Adjust.	Name	New Settings
A.1 04	Maximum Extra Ball	Off
A.1 05	Replay system	Fixed
A.1 09	Replay Level 1	Off
A.1 10	Replay Level 2	Off
A.1 11	Replay Level 3	Off
A.1 12	Replay Level 4	Off
A.1 15	Special Award	Points
A.1 19	Match Feature	Off
A.4 01	Highest Score	On
A.4 04	Champion Credit	00
A.4 05	High Score 1 Credits	00
A.4 06	High Score 2 Credits	00
A.4 07	High Score 3 Credits	00
A.4 08	High Score 4 Credits	00
A.4 16	Monster Bash Credits	00
A.4 18	Monsters of Rock Credits	00

U.9 11 NOT USED

U.9 12 SERIAL CAPTURE

This sets up the printer adjustments for a serial transmission to a laptop computer, (9600 baud, 40 column, no page breaks, serial printer). This option requires the installation of the optional printer kit; part number 63110.

U.9 13 TO U.9 16 NOT USED

- U.9 17 INSTALL GERMAN 1**
- U.9 18 INSTALL GERMAN 2**
- U.9 19 INSTALL GERMAN 3**
- U.9 20 INSTALL GERMAN 4**
- U.9 21 INSTALL GERMAN 5**
- U.9 22 INSTALL GERMAN 6**

Adjustments U.9 17 through U.9 22 are used to modify game pricing and type of play.

- U.9 23 INSTALL FRENCH 1**
- U.9 24 INSTALL FRENCH 2**
- U.9 25 INSTALL FRENCH 3**
- U.9 26 INSTALL FRENCH 4**
- U.9 27 INSTALL FRENCH 5**
- U.9 28 INSTALL FRENCH 6**

Adjustments U.9 23 through U.9 28 are used to modify game pricing and type of play.

U.10 CLEAR CREDITS

Press the Enter button to clear the game Credits.

U.11 AUTO BURN-IN

Press the Enter button to activate Auto Burn-in. This utility automatically cycles through several tests. This helps in finding intermittent problems. The tests that Auto Burn-in cycles through are: the Display Test, the Sound and Music Test, the All Lamps Test, the Solenoid Test, the Flashers Test, the General Illumination Test, and the Flipper Coil Test. All of the tests run concurrently. The time spent on the burn-in cycle and the total time the game has spent in burn-in are displayed.

U.12 RESET PHANTOM FLIP DATA

This Utility is used to reset all the shot timing data accumulated by the Phantom Flip feature.

Press the Up or Down buttons to scroll through the Adjustments menu. To access an adjustment menu option, press the Enter button. To see the setting choices for that option press the Up and Down buttons. To lock in a setting choice, press the Enter button. If you make a mistake, press the Escape button while "Saving Adjustment Value" is in the display. The original value is retained and the new value is ignored. Press the Escape button to return to the Adjustment menu.

A. ADJUSTMENTS MENU

A.1 Standard Adjustments

A.2 Feature Adjustments

A.3 Pricing Adjustments

A.4 H.S.T.D Adjustments

A.5 Printer Adjustments (optional board required)

A.1 STANDARD ADJUSTMENTS

A.1 01 BALLS PER GAME

A "game" is defined by specifying the number of balls to be played.

Settings: 1 to 10

Factory Default: 3

A.1 02 TILT WARNINGS

The number of total actuation's of the plumb bob that can occur before the game is "tilted".

Settings: 1 to 10

Factory Default: 3

A.1 03 MAXIMUM EXTRA BALLS COUNT

The number of extra balls that a player may accumulate.

Settings: 0 to 10
NO EXTRA BALL - No extra balls may be accumulated.

Factory Default: 4

A.1 04 MAXIMUM EXTRA BALLS PER BALL IN PLAY

The number of extra balls to be awarded per ball in play.

Settings: OFF - No maximum number of extra balls per ball in play.
1 to 10 - 1 through 10 extra balls per ball in play.

Factory Default: OFF

A.1 05 REPLAY SYSTEM

The type of replay system to be used.

Settings: FIXED - Replay value is set and does not change during game play.
AUTO % - Replay starting value is set but changes every 50 games to comply with the percentage of replays desired.
OFF - Disable the replay system. No replays are awarded.

Factory Default: AUTO %

A.1 06 REPLAY PERCENT

The percentage of replays the players are able to earn when Auto Replay is used.

Settings: 5% to 50%

Factory Default: 10%

A.1 07 REPLAY START

Replay Start value when Auto % Replay is used.

Settings: 5,000,000 to 300,000,000

Factory Default: 30,000,000

A.1 08 REPLAY LEVELS

The number of replay levels used by the Auto % Replay mode. When two replay levels are chosen, the second replay level is automatically adjusted to twice the starting replay level. When three or four replay levels are chosen, their values are automatically adjusted to three or four times the starting replay level.

Settings: 1 to 4

Factory Default: 1

A.1 09 REPLAY LEVEL 1

A.1 10 REPLAY LEVEL 2

A.1 11 REPLAY LEVEL 3

A.1 12 REPLAY LEVEL 4

The value to be used for the 1st through 4th Fixed Replay.

Settings: 00 to 300,000,000.

A.1 13 REPLAY BOOST

The replay score can be temporarily boosted by the selected amount EACH time the player reaches or exceeds the replay score. This temporary boost is canceled when credits equal 0; the player inserts another coin, or when Begin Test is pressed.

Settings: AUTO - The Replay Boost value is half of the current Replay value.
ON - Score is boosted between 2,000,000 and 25,000,000 points.
OFF - Replay score is not boosted.

Factory Default: AUTO

A.1 14 REPLAY AWARD

The form of award automatically provided when the player exceeds any replay level for either Auto % Replay or Fixed Replay.

Settings: CREDIT - Reaching each replay level awards credit.
TICKET - Reaching each replay level awards a ticket.
BALL - Reaching each replay level awards an extra ball.
AUDIT - Reaching each replay level awards nothing to the player; it does increase the entry value of the audit item(s) maintaining a tally of these awards.

Factory Default: CREDIT

A.1 15 NOT USED

A.1 16 MATCH AWARD

The award automatically provided when the players win a match.

Settings: CREDIT - Winning a match awards a credit.
TICKET - Winning a match awards a ticket.

Factory Default: CREDIT

A.1 17 EXTRA BALL TICKET

A ticket is awarded when the player earns an extra ball.

Settings: YES - The player is awarded a ticket in addition to an extra ball.
NO - The player is not awarded a ticket.

Factory Default: NO

A.1 18 MAXIMUM TICKET/PLAYER

The amount of tickets each player can earn.

Settings: 00 to 100.

Factory Default: 25

A.1 19 MATCH FEATURE

This is the desired percentage for the Match Feature occurring at the end of the game.

Settings: OFF - Match Feature is not available.
1 to 50% - 1% is 'hard'; 50% is 'extremely easy'. The Match Feature selects random points score value at the end of the game and compares each player's score for an identical match. A match of an entire score value results in an award of a Credit or a Ticket.

Factory Default: 7%

A.1 20 CUSTOM MESSAGE

The message displayed during the Attract mode.

Settings: ON - A message is displayed
OFF - A message is not displayed.

Factory Default: ON

A.1 21 LANGUAGE

The language the game uses.

Settings: ENGLISH, FRENCH, OR GERMAN

Factory Default: ENGLISH

A.1 22 CLOCK STYLE

The style of clock the game uses.

Settings: A.M./P.M. or 24 hours.

Factory Default: A.M./P.M.

A.1 23 DATE STYLE

The style of dates the game uses.

Settings: MONTH/DATE/YEAR OR DATE/MONTH/YEAR

Factory Default: MONTH/DATE/YEAR

A.1 24 SHOW DATE AND TIME

The date and time show in the Attract mode.

Settings: YES - Show the date, time in status report or in the Attract mode.
NO - Do not show date, time in status report or in the Attract mode.

Factory Default: NO

A.1 25 ALLOW DIM ILLUMINATION

The game program dims the general illumination for special effects and during the Attract mode.

Settings: YES - Dim the general illumination during the Attract mode.
NO - Do not dim the general illumination.

Factory Default: YES

A.1 26 TOURNAMENT PLAY

Equalize random game features and global score values during multi-player games.

Settings: YES - Equalize random game features and global score values.
NO - Do not equalize random game features and global score values.

Factory Default: NO

A.1 27 EUROPEAN SCORE FORMAT

Use either commas or dots between digits when numbers are displayed.

Settings: YES - Dots instead of commas, (example- 1.000.000).
NO - Commas instead of dots, (example- 1, 000, 000).

Factory Default: NO

A.1 28 MINIMUM VOLUME OVERRIDE

The volume can be turned off.

Settings: YES - Volume can be turned off.
NO - Volume can be turned down but not off.

Factory Default: NO

A.1 29 GENERAL ILLUMINATION POWER SAVER

This allows the general illumination and controlled lamps to be dimmed following a time interval after a game is played. Power Saver Level (A.1 30) determines dimness of the lamps. Using this feature substantially increases the life of the lamps.

Settings: OFF, 2 to 60 minutes.

Factory Default: 15 minutes

A.1 30 POWER SAVER LEVEL

When General Illumination Power Saver (A.1 29) is set for 2 to 60 minutes, the Power Saver Level controls the intensity of the general illumination and controlled lamps after the game has been idle for the specified period of time.

Settings: 4 to 7 (4 = dimmest, 7 = brightest)

Factory Default: 5

A.1 31 TICKET EXPANSION BOARD

When a Ticket Expansion board is connected, full control of the ticket dispenser is available. This includes a ticket low/error lamp, resume on ticket jam switch and manual ticket dispense switch.

Settings: YES - Ticket Expansion board is connected.
NO - Ticket Expansion board is NOT installed in the game.

Factory Default: NO

A.1 32 NO BONUS FLIPS

The activation of flippers during the end of ball "bonus" sequence. Setting to "YES" may extend the life of the flipper mechanisms.

Settings: YES, NO

Factory Default: YES

A.1 33 GAME RESTART

When you press the Start button during or after the 2nd ball, the game in progress ends and a new game begins. This adjustment has three settings to determine how to handle this.

Settings: NEVER - Do not allow a new game start until the current game is over.
SLOW - Restart if the Start button is pressed continuously for over 1/2 second. This helps to prevent the unintended restart of the game in progress.
INSTANTLY - Restart as soon as the Start button is pressed.

When you press the Start button during game over, or during the 1st ball (to add a player), it is always handled instantly.

Factory Default: SLOW

A.1 34 ALLOW CHASE BALL

The Chase Ball feature will attempt to keep a game operational in the event that a ball becomes stuck on the playfield. After a number of unsuccessful ball searches, the game software will end the player's current ball, give a bonus award, then serve a new ball (or end the game if that was the last ball in the player's game). This ball 'chases' the stuck ball on the playfield and will hopefully knock it loose.

Setting this adjustment to NO will revert to the previous WPC behavior of searching endlessly until the stuck ball becomes freed, or the machine's power is turned off and back on.

Settings: YES, NO
Factory Default: YES

A.2 FEATURE ADJUSTMENTS

A.2 01 BALL SAVES

This adjustment determines the number of "full" Ball Saves that each player receives in a game. A ball that is "saved" will be returned to play without a change in the player up number or the ball in play number. A "full" Ball Save is "used" if a ball drains after it is launched into play within the amount of time specified by A.2 02 (Ball Save Time). Once all "full" Ball Saves are used, balls will no longer be returned to play should they drain quickly after being launched into play.

Settings: OFF - Balls will not be saved.
01-05: 1 to 5 "full" Ball Saves given to each player per game.

A.2 02 BALL SAVE TIME

This adjustment determines the number of seconds in which a ball may drain after being launched into play, such that it will be returned to play without a change in the player up number or the ball in play number.

Settings: 03-15: 3 to 15 seconds.

A.2 03 EXTRA BALL PERCENTAGE

This adjustment determines the total percentage of Extra Balls desired (for all Extra Balls awarded from all features except Replay Score levels). The game will adjust the percentage of the Random Award (Concert Hall) "Light Extra Ball" award to achieve the requested percentage. When this adjustment is set to "FIXED", no automatic percentaging will be done for the Random Award "Light Extra Ball" Award; it will operate with a FIXED percentage of 2%.

Settings: FIXED - Do not percentage the Random Award "Light Extra Ball" Award.
15-40: Percentage the Random Award "Light Extra Ball" Award to achieve this percentage.

A.2 04 CREATURE FEATURE TIMER

This adjustment specifies the number of seconds the player has to complete a shot during Creature Feature.

Settings: 10-30: The starting number of seconds for the timer.

A.2 05 BALL AND CHAIN TIMER

This adjustment specifies the number of seconds in which the player has to complete the Ball and Chain feature.

Settings: 20-40: The starting number of seconds for the timer.

A.2 06 FRANKENSTEIN BODY PART SPOT BALL START

This adjustment specifies whether or not Frankenstein Body Parts are spotted for the first Frankenstein Multiball at the start of each ball. Setting this adjustment to YES makes the first Frankenstein Multiball easier to achieve.

Settings: YES - Spot Frankenstein Body Parts.
NO - Do not spot Frankenstein Body Parts.

A.2 07 MUMMY MAYHEM TIMER

This adjustment specifies the number of seconds in which the player has to complete the Mummy Mayhem feature.

Settings: 30-60: The starting number of seconds for the timer.

A.2 08 DRACULA LETTERS

This adjustment specifies the number of free Dracula letters that are given to each player at the start of a game. The higher this number is, the easier it is to light the Drac-Attack feature.

Settings: 00-06: The starting number of Dracula letters.

A.2 09 DRAC-ATTACK TIMER

This adjustment specifies the number of seconds in which the player has to hit Dracula during Drac-Attack.

Settings: 20-40: The starting number of seconds for the timer.

A.2 10 MONSTERS EXTRA BALL

This adjustment specifies the number of Monsters that must be collected to light an Extra Ball.

Settings: OFF - Do NOT light an Extra Ball for collecting Monsters.
1-6: Light and Extra Ball for collecting this number of Monsters.

A.2 11 INSTRUMENT SPECIAL

This adjustment specifies the number of Instruments that must be collected to light a Special.

Settings: OFF - Do NOT light a Special for collecting Instruments.
1-6: Light a Special for collecting this number of Instruments.

A.2 12 MAXIMUM INSTRUMENTS SPECIALS

This adjustment limits the number of Specials that can be lit for collecting Instruments.

Settings: 1-10: The number of times the Special can be lit.
UNLIMITED - Instrument Specials can be lit an unlimited number of times.

A.2 13 CENTER LOOP EXTRA BALL 1

This adjustment specifies the number of Center Loop shots that must be made before lighting the first Center Loop Extra Ball.

Settings: NO EXTRA BALL - Do not light the first Extra Ball from the Center Loop.
3, 6, 9, 12, 15 - Light an Extra Ball when this number of Center Loop shots is made.

A.2 14 CENTER LOOP EXTRA BALL 2

This adjustment specifies the number of Center Loop shots that must be made before lighting the second Center Loop Extra Ball.

Settings: NO EXTRA BALL - Do not light the second Extra Ball from the Center Loop.
24, 27, 30, 33, 36 - Light an Extra Ball when this number of Center Loop shots is made.

A.2 15 SPECIAL MEMORY

This adjustment determines whether or not lit Specials remain in memory from ball to ball.

Settings: YES - Specials stay lit from ball to ball.
NO - Specials will be turned off at the start of each ball.

A.2 16 PHANTOM FLIP BALL SAVE

This adjustment allows activation of the ball save feature for a brief period when an automatic flip is underway.

Settings: YES - Activate the ball save feature during automatic flips.
NO - Do not activate the ball save feature.

A.2 17 KNOCKER SOUND

This adjustment is used to turn off the knocker sound.

Settings: OFF – Disable the knocker sound.
 NO – Kocker sound active.

A.2 18 PLAYER TOURNAMENT MODE

This adjustment determines whether or not lit Specials remain in memory from ball to ball.

Settings: YES - Specials stay lit from ball to ball.
 NO - Specials will be turned off at the start of each ball.

A.2 19 FAMILY MODE

This adjustment allows the game to operate in "Family Mode". Any possibly offensive or objectionable dot matrix images and sounds will not be utilized.

Settings: YES - Do NOT utilize any possibly offensive or objectionable dot matrix images and sounds.
 NO - Utilize all dot matrix images and sounds.

A.2 20 ATTRACT MODE MUSIC

This adjustment is used to allow the playing of music in Attract Mode.

Settings: YES - Allow music to be played in Attract Mode.
 NO - Do NOT allow music to be played in Attract Mode.

A.2 21 ATTRACT MODE SOUND

This adjustment is used to allow the playing of sound effects in Attract Mode.

Settings: YES - Allow sounds effects to be played in Attract Mode.
 NO - Do NOT allow sound effects to be played in Attract Mode.

A.2 22 TIMED PLUNGER

This adjustment specifies the number of seconds before automatically plunging a ball onto the playfield that can otherwise be plunged by the player via the launch button.

Settings: OFF - Never automatically plunge a ball onto the playfield that can otherwise be plunged by the player via the launch button.
 30-90: The number of seconds before automatically plunging the ball.

A.2 23 FLIPPER PLUNGER

When this adjustment is set to YES, the right flipper will cause a ball sitting in the shooter lane to be launched onto the playfield. This adjustment is provided for use when the launch button is broken and/or intermittent. The game will automatically detect a broken launch button, but it may take several games to perform the detection. In this case, set this adjustment to YES until the launch button can be repaired.

Settings: YES - Allow the right flipper to launch a ball sitting in the shooter lane.
 NO - Do NOT allow the right flipper to launch a ball sitting in the shooter lane.

A.2 24 DISABLE PHANTOM FLIP

This adjustment is used to disable the Phantom Flip feature.

Settings: YES - Disable the feature.
 NO - Do NOT disable the feature.

A.2 25 DISABLE UP/DOWN BANK

This adjustment is provided for use when the Up/Down Bank is broken and/or intermittent. The game will automatically detect a broken Up/Down Bank, but it may take several games to perform the detection. In this case, set this adjustment to YES until the Up/Down Bank can be repaired.

If it is necessary to set this adjustment to YES, and the Up/Down Bank motor is operable, use T.17 (Up/Down Bank Test) to move the Bank to its UP or its DOWN position. This will minimize possible damage to the top of the unit during game play, and provide for better game-play software compensation.

Settings: YES - Disable the Up/Down Bank.
NO - Do NOT disable the Up/Down Bank.

A.2 26 DISABLE FRANKENSTEIN TABLE

This adjustment is provided for use when the Frankenstein Table is broken and/or intermittent. The game will automatically detect a broken Frankenstein Table, but it may take several games to perform the detection. In this case, set this adjustment to YES until the Frankenstein Table can be repaired.

If it is necessary to set this adjustment to YES, and the Frankenstein Table motor is operable, use T.18 (Frankenstein Table Test) to move the Table to its UP or its DOWN position. This will minimize possible damage to the bottom of the unit during game play, and provide for better game-play software compensation.

Settings: YES - Disable the Frankenstein Table.
NO - Do NOT disable the Frankenstein Table.

A.2 27 DISABLE RAMP LOCK POST

This adjustment is used to disable the Ramp Lock Post.

Settings: YES - Disable the Ramp Lock Post.
NO - Do NOT disable the Ramp Lock Post.

A.2 29 DISABLE MUMMY

This adjustment is used to disable the Mummy Coffin.

Settings: YES - Disable the Mummy Coffin.
NO - Do NOT disable the Mummy Coffin.

A.2 30 DISABLE LEFT GATE

This adjustment is provided for use when the Left Gate is broken and/or intermittent. The game will automatically detect a broken Left Gate, but it may take several games to perform the detection. In this case, set this adjustment to YES until the Left Gate can be repaired.

Settings: YES - Disable the Left Gate.
NO - Do NOT disable the Left Gate.

A.2 31 DISABLE RIGHT GATE

This adjustment is provided for use when the Right Gate is broken and/or intermittent. The game will automatically detect a broken Right Gate, but it may take several games to perform the detection. In this case, set this adjustment to YES until the Right Gate can be repaired.

Settings: YES - Disable the Right Gate.
NO - Do NOT disable the Right Gate.

A.2 32 DISABLE DRACULA

This adjustment is provided for use when the Dracula mechanism is broken and/or intermittent. The game will automatically detect a broken Dracula mechanism, but it may take several games to perform the detection. In this case, set this adjustment to YES until the Dracula mechanism can be repaired.

Settings: YES - Disable the Dracula Mechanism.
 NO - Do NOT disable the Dracula Mechanism.

A. 3 PRICING ADJUSTMENTS

A.3 01 GAME PRICING (If set to custom, then 02 to 09 are available).

The cost of a game is selected here from the Standard Pricing Table or by using the custom pricing editor (A.3 27).

A.3 02 to A.2 09 NOT USED

A.3 10 COIN DOOR TYPE (If set to custom, then 11 to 15, 20 and 25 are available).

This adjustment is used to preset adjustments 11 through 15, 20 and 25, based on standard coin doors.

A.3 11 COLLECTION TEXT

The coin system is used to display the Earning Audits.

A.3 12 LEFT SLOT VALUE

A.3 13 CENTER SLOT VALUE

A.3 14 RIGHT SLOT VALUE

A.3 15 4TH SLOT VALUE

These are the values for the coins for these respective coin slots. These values are used for determining collection totals. The corresponding adjustments A.3 28 (Left Slot Credit Value) through A.3 31 (4th Slot Credit Value) typically contain the same values and are used to determine the number of credits awarded for the coin slot. Whenever these values are changed, the new value is copied to the corresponding A.3 28 through A.3 31 adjustment. If a bonus is desired for a particular coin (such as three credits for dollar coin), then the corresponding A.3 28 through A.3 31 "Credit Value" adjustment should be modified to award the bonus. See "Bonus for Special Coin" section for more information.

A.3 16 MAXIMUM CREDITS

The maximum number of credits the game can accumulate, either through game plays awards or coin purchases. The range of this setting is 5 through 99. Reaching the specified setting prevents the award of any credits. Factory default is 10.

A.3 17 FREE PLAY

A player can operate the game without a coin (free play), or with a coin.

- NO - A coin is necessary for game play.
- YES - Game play is free; no coin required.

A.3 18 HIDE COIN AUDITS

The coin audits may, or may not, be displayed.

- YES - The coin audits are not displayed.
- NO - The coin audits are displayed.
- HIDE NAMES - The coin audit value is shown but not the audit name.

A.3 19 NOT USED

A.3 20 BASE COIN SIZE

This is the smallest unit of coin that may be used when creating a custom pricing mode using the Pricing Editor (A.3 27). For example, in the USA this is typically \$0.25. All pricing levels are then specified in 25 cents (or greater) increments.

A.3 21 COIN METER UNITS

The adjustment determines the value of each coin unit on the coin meter. For example, to show the total amount of money collected as total quarters, set the adjustment to 0.25. To show the total amount of money collected as "total dollars", set this adjustment to 1.00. Setting this adjustment to anything other than OFF establishes the coin unit for the meter installed on the Coin Door Interface board. **Note:** All WPC-95 games are cable ready to operate a coin meter mounted to the Coin Door Interface board. Boards without a meter can use the parts listed below to take advantage of the coin meter feature. The coin meter and spacer may be purchased from your distributor. coin meter +6V p/n 20-9302-3; spacer p/n 20-9914

A.3 22 DOLLAR BILL SLOT

The system normally requires 150 microseconds between coin pulses. This is too long a delay for a fast-pulsing dollar bill validator. This adjustment may be used to tell the game that there is a fast-pulsing dollar bill validator connected to one of the coin switches.

NONE = No validator connected.
LEFT = Validator connected to left slot.
CENTER = Validator connected to center slot.
RIGHT = Validator connected to right slot
FOURTH = Validator connected to fourth.

A.3 23 MINIMUM COIN MILLISECONDS

This is the minimum width required for coin pulses to be accepted as valid coins. This may be changed to prevent certain kinds of cheating.

A.3 24 NOT USED

A.3 25 ALLOW HUNDREDTHS

This is used for a custom door specifier. If set to YES, then the values for A.3 12-15 are specified in units and hundredths (such as dollars and quarters). If set to NO, then all values are in units (such as Francs and Lire.)

A.3 26 CREDIT FRACTION

This determines the smallest fraction used for credits. It must be even to accommodate the extra ball buy-in option of 1/2 credit, and is typically 1/2 but may need to be a different value for modes requiring more coins per credit.

A.3 27 PRICING EDITOR

This function is now used to enter information for a custom pricing mode. The adjustment A.3 26 (Credit Fraction) may need to be set before entering the custom pricing editor. This specifies the smallest fraction available for partial credits.

Because of availability of an extra ball (buy-in) for 1/2 credit, this value is always even (1/2, 1/4, 1/6etc.). The typical setting for A.3 26 is 1/2 (such that there are only full credits and half credits) but you may need to use a different value for other pricing modes.

Please note that formerly, the coin values specified by custom coin doors adjustments A.3 12-15 only affected audit totals that showed collection totals. In the 10/94 pricing system, these coin values are added up for each coin received and credits are awarded based on pricing levels being reached. The pricing editor described here allows you to set these levels, however it may be necessary for you to set A.3 10 (Coin Door Type) to CUSTOM and then change A.3 11-15, 20 and 25 to reflect the value of the coins being used. This is usually NOT NECESSARY, but must be done BEFORE using the custom pricing editor when it is necessary.

Begin the custom pricing function by pressing the Enter button while A.3 27 Pricing Editor is showing in the display.

The pricing editor will now show the data for the currently selected pricing mode. If this is the 1st use of the pricing editor then this will show the last built-in pricing that was selected. Otherwise it will be the last custom mode created by this function. (Note that A.3 01 will display Custom any time a non-standard pricing has been selected.)

Assuming the last mode installed was 1/\$0.50, 2/\$0.75, 3/\$1.00 the display appears as follows:

CUSTOM PRICING EDITOR		
1)	\$0.25	1/2 cred.
2)	\$0.50	1 cred.
3)	\$0.75	2 cred.
4)	\$1.00	3 cred.

DISPLAY VIEW

The \$0.25 field will be flashing. You may now use the test mode buttons to perform the following functions:

Escape:

Undo any changes to the current field and move to the previous field.

"-" (Down):

Make the current field lower.

"+" (Up):

Make the current field higher.

Enter:

Save any changes to the current field and move to the next field. Note that there are 2 columns of fields. Price levels are in the left column and credit levels are in the right column. Pressing Enter will move from left column to right column before moving to the next line.

Start:

Save the current price mode or start over

By using the above functions, you simply enumerate each pricing level and the number of credits that should be awarded at that level. Please note that you must specify each fractional level in sequence.

Example:	1/\$0.50	2/\$1.00	4/\$1.50	6/\$2.00
1)	\$0.25	1/2 cred.		
2)	\$0.50	1 cred.		
3)	\$0.75	1 1/2 cred.		
4)	\$1.00	2 cred.		
5)	\$1.25	2 1/2 cred.		
6)	\$1.50	4 cred.		
7)	\$1.75	4 1/2 cred.		
8)	\$2.00	6 cred.		

Also note that once the value of the coins repeat that no further specification is necessary.

Example:	1/\$0.50	2/\$1.00
1)	\$0.25	1/2 cred.

In the above example, only one line needs to be specified, indicating that 1/2 credit is awarded for each \$0.25 received.

Special Features:

There are some special features available by pressing the Down button while in the left column. The following words will be displayed instead of a pricing level:

<i>End</i>	<i>Repeat 3</i>	<i>Repeat 9</i>	<i>Repeat 15</i>
<i>Delete</i>	<i>Repeat 4</i>	<i>Repeat 10</i>	<i>Repeat 16</i>
<i>Insert</i>	<i>Repeat 5</i>	<i>Repeat 11</i>	<i>Repeat 17</i>
<i>Clear</i>	<i>Repeat 6</i>	<i>Repeat 12</i>	<i>Repeat 18</i>
<i>Repeat 1</i>	<i>Repeat 7</i>	<i>Repeat 13</i>	<i>Repeat 19</i>
<i>Repeat 2</i>	<i>Repeat 8</i>	<i>Repeat 14</i>	<i>Repeat 20</i>

Pressing Enter with the above words selected will activate the following instructions:

End

This is the same as pressing the Start button. A menu of choices will be provided (see Start Button later in this section).

Delete

This deletes the current level from the pricing mode.

Insert

This inserts a new pricing level ABOVE the current level. The current level will be unaffected. There must be room for at least one coin between the current level and the previous level, and at least one fractional credit unit between the current level and the previous level.

Example: Inserting a new pricing level.

CUSTOM PRICING EDITOR		
1)	\$0.50	1 cred.
2)	\$1.00	2 cred.
3)	\$1.50	4 cred.
4)	\$2.00	6 cred

DISPLAY VIEW

Use the Enter button to move to the \$1.50 field. Now press the Down button once to create the following display:

CUSTOM PRICING EDITOR		
1)	\$0.50	1 cred.
2)	\$1.00	2 cred.
3)	INSERT	4 cred.
4)	\$2.00	6 cred

DISPLAY VIEW

Now press the Enter button. The display will now show:

CUSTOM PRICING EDITOR		
1)	\$0.50	1 cred.
2)	\$1.00	2 cred.
3)	\$1.25	2 1/2 cred.
4)	\$1.50	4 cred

DISPLAY VI

Note that the line "5) \$2.00 6 cred." No longer fits on the display. Whenever there are more than four pricing levels that the display will scroll up and down as Enter and Escape are used to move from field to field. If you repeatedly press Enter the display will then show:

CUSTOM PRICING EDITOR		
2)	\$1.00	2 cred.
3)	\$1.25	2 1/2 cred.
4)	\$1.50	4 cred.
5)	\$2.00	6 cred

DISPLAY VIEW

Clear

This clears out the current entries to allow a new pricing mode to be entered.

Repeat (1-20)

This causes all of the entries above the current line to be repeated the number of times specified. This is only available when there are no pricing levels below the current line.

Example: 1/\$0.50 2/\$1.00 15/\$5.00

Use the "Edit New Pricing Mode" feature described below to clear out the current levels.

Use the Up and Enter buttons to specify 1/2 credit for \$0.25:

CUSTOM PRICING EDITOR		
1)	\$0.25	1/2 cred.

DISPLAY VIEW

Now, use the Up button until the display shows "Repeat 20". The display looks like this:

CUSTOM PRICING EDITOR		
1)	\$0.50	1 cred.
2)	REPEAT 20	

DISPLAY VIEW

Press the Enter button and the display will show the following:

CUSTOM PRICING EDITOR		
1)	\$0.25	1/2 cred.
2)	\$0.50	1 cred.
3)	\$0.75	1 1/2 cred.
4)	\$1.00	2 cred

DISPLAY VIEW

Actually, by repeating the 1st line 20 times the pricing mode is currently set up as follows, but only the 1st four lines are displayed.

CUSTOM PRICING EDITOR		
1)	\$0.25	1 /2 cred.
2)	\$0.50	1 cred.
3)	\$0.75	1 1/2 cred.
4)	\$1.00	2 cred.
5)	\$1.25	2 1/2 cred.
6)	\$1.50	3 cred.
7)	\$1.75	3 1/2 cred.
8)	\$2.00	4 cred.
9)	\$2.25	4 1/2 cred.
10)	\$2.50	5 cred.
11)	\$2.75	5 1/2 cred.
12)	\$3.00	6 cred.
13)	\$3.25	6 1/2 cred.
14)	\$3.50	7 cred.
15)	\$3.75	7 1/2 cred.
16)	\$4.00	8 cred.
17)	\$4.25	8 1/2 cred
18)	\$4.50	9 cred.
19)	\$4.75	9 1/2 cred.
20)	\$5.00	10 cred

DISPLAY VIEW

Now repeatedly press the Enter button to move the right hand column to the 20th level. The display will show (with "10 cred." Blinking):

CUSTOM PRICING EDITOR		
17)	\$4.25	8 1/2 cred.
18)	\$4.50	9 cred.
19)	\$4.75	9 1/2 cred.
20)	\$5.00	10 cred

DISPLAY VIEW

Now press the Up button repeatedly until the right hand column of line 20 reads "15 cred."

Start Button

Once the pricing mode has been specified, you exit the custom pricing editor by pressing the 'Start' button. This will bring up a menu with some or all of the following choices:

Choose an Option:
Return to Editor
Clear Pricing
Ignore Changes
Save Changes

DISPLAY VIEW

Use the Up and Down buttons to select your choice and press the Enter button to activate it. The selections cause the following actions:

Return To Editor

This option will allow you to continue to edit the pricing information.

Clear Pricing

This option will clear out all pricing levels and bring you back to the pricing editor to create a pricing mode from scratch.

Ignore Changes

This option will discard the work done in the previous pricing editor and leave the previously installed pricing mode in the game.

Save Changes

Press the Enter button to save your custom edited pricing mode and install it as the pricing for the game. Note that this choice will not be displayed if there is not at least one pricing level specified in the pricing editor, or if no changes have been made.

Exit Pricing Editor

This option will appear if no changes have been made. It will exit the Pricing Editor leaving the pricing as is.

Bonus for Special Coins

For most coin modes, the system allows the mixing of any combination of any size coin and awards credits as each appropriate amount is accumulated. With A.3 10 (Coin Door Type) set to "custom", the value of each coin slot may be entered for adjustments A.3 12 (Left Slot Value) through A.3 15 (4th slot value). Whenever these values are changed, the new values are copied to A.3 28 (Left Slot Credit Value) through A.3 31 (4th Slot Credit Value) respectively. To give a bonus for a particular coin, you need to modify the Credit Value adjustment to specify the value to be given for the bonus coin.

For example, in a game with a Left Coin Slot that takes quarters and a center coin slot that takes dollars, if you wish to charge 50 cents for 1 play and \$1.00 for 2 plays, you setup the pricing editor to show:

CUSTOM PRICING EDITOR		
1)	\$0.25	1/2 cred.
2)	\$0.50	1 cred.
3)	\$0.75	1-1/2 cred.
4)	\$1.00	2 cred

DISPLAY VIEW

If you set A.3 10 (Coin Door Type) to Custom you will see the following coin door specifier adjustments:

A.3 12	Left Slot Value	0.25
A.3 13	Center Slot Value	1.00
A.3 28	Left Slot Credit Value	0.25
A.3 29	Center Slot Credit Value	1.00

To change the pricing to 1 play for \$0.50, 2 plays for \$1.00 and 3 plays for a dollar coin, you change A.3 29 (Center Slot Credit Value) to 1.50. This will result in the following settings:

A.3 12	Left Slot Value	0.25
A.3 13	Center Slot Value	1.00
A.3 28	Left Slot Credit Value	0.25
A.3 29	Center Slot Credit Value	1.50

This will cause \$1.50 worth of credits (3) to be awarded for each coin inserted in the center coin slot (dollar coin). This is due to the \$1.50 setting of A.3 29 (Center Slot CREDIT VALUE). Note that the 1.00 setting of A.3 13 tells the game that each coin in the center slot adds \$1.00 to the total collection.

A.3 28 LEFT SLOT CREDIT VALUE

A.3 29 CENTER SLOT CREDIT VALUE

A.3 30 RIGHT SLOT CREDIT VALUE

A.3 31 4TH SLOT CREDIT VALUE

This adjustment specifies the value to be used for awarding credits. It is typically the same value as the corresponding A.3 12 (Left Slot Value) through A.3 15 (4th Slot Value) adjustment.

The A.3 12 through A.3 15 values are used to determine the auditing value of each coin (for collection totals) while the A.3 28 through A.3 31 value determine the coin value for awarding credits. By making this "Credit Value" adjustment higher than the A.3 12 through A.3 15 "Value" adjustment, a bonus may be given for a specific call (see Bonus for Special Coin section for more information).

Pricing Table

COUNTRY	COIN CHUTES			4 TH CHUTE	GAMES/COINS	DISPLAY	PRICING ADJUSTMENTS A3 02 03 04 05 06 07 08 09
	LEFT	CENTER	RIGHT				
USA	25¢	\$1.00*	25¢	\$1.00	1/50¢, 2/75¢, 3/\$1 ²	50¢, 75¢, \$1.00	
	25¢	\$1.00*	25¢	\$1.00	1/75¢, 2/\$1.50, 3/\$2.00 ²	1/.75, 3/2.00	
	25¢	\$1.00	25¢	\$1.00	1/3X25¢ ²	USA 1/\$0.75	
	25¢	\$1.00	25¢	\$1.00	1/50¢, 2/\$1 ²	USA 2/\$1.00	
	25¢	\$1.00	25¢	\$1.00	1/50¢, 3/\$1.00 ²	USA 3/\$1.00	
	25¢	\$1.00	25¢	\$1.00	1/2x25¢, 2/\$1.00, 3/\$1.50, 6/\$2.00 ²	USA 6/\$2.00	
	25¢	\$1.00	25¢	\$1.00	1/2x25¢, 2/\$1.00, 3/\$1.50, 5/\$2.00 ^{1,2}	USA 5/\$2.00	
	25¢	\$1.00	25¢	\$1.00	1/3x25¢, 2/\$1.50, 4/\$2.00 ²	1/.75, 4/\$2.00	
	25¢	\$1.00	25¢	\$1.00	1/2x25¢, 2/\$1.00, 4/\$1.50, 6/\$2.00 ²	6/\$2.00 4/\$1.50	
	25¢	25¢	25¢	-	1/4x25¢, 6/\$5.00 ²	1/1, 6/5	
	25¢	25¢	25¢	-	1/4x25¢ ²	1/\$1.00	
Canada	25¢	-	\$1.00	-	1/50¢, 2/75¢, 3/\$1 ²	CAN. 50-75-1	
	25¢	-	\$1.00	-	1/50¢, 2/\$1 ²	CAN. 2/\$1.00	
	25¢	-	\$1.00	-	1/50¢, 3/\$1.00 ²	CAN. 3/\$1.00	
	25¢	-	\$1.00	-	1/2x25¢, 2/4x25¢, 3/\$1.00 ²	3/\$1.00 Coin	
	25¢	-	\$1.00	-	1/2x25¢, 2/\$1.00, 3/\$1.50, 6/\$2.00 ²	CAN. 6/\$2.00	
	25¢	-	\$1.00	-	1/2x25¢, 2/\$1.00, 3/\$1.50, 5/\$2.00 ^{1,2}	CAN. 5/\$2.00	
	25¢	-	\$1.00	-	1/2x25¢, 2/\$1.00, 4/\$1.50, 6/\$2.00 ²	6/\$2, 4/1.50	
	25¢	-	\$1.00	-	1/3x25¢, 2/\$1.50, 4/\$2.00 ²	1/.75, 4/2.00	
	25¢	-	\$1.00	-	1/75¢, 2/\$1.50, 3/\$2.00 ²	1/.75, 3/2.00	
	25¢	-	\$1.00	-	1/3X25¢ ²	CAN. 1/\$0.75	
Canada 3/Dollar Coin	25¢	-	\$1.00	-	1/0.50, 2/\$1.00, 3/\$1.00-Coin	CAN.\$ BONUS	
Austria	5sch	10sch	10sch	-	1/2x5sch, 3/2x10sch ²	AUSTRIA	
	5sch	-	10sch	-	12/5sch, 5/10sch	CUSTOM	02 00 05 00 01 00 01 00
Australia	20¢	\$1	\$1	\$2	1/\$1, 3/\$2 ²	AUSTRALIA 1	
	20¢	\$1	\$1	\$2	1/\$1, 2/\$2	AUSTRALIA 2	
U.K.	£1.00	50P	20P	10P	1/3x10P, 2/50P, 4/£1 ²	U. KINGDOM	
Switzerland	1Fr	2Fr	5Fr	-	1/1Fr, 3/2Fr, 7/5Fr ²	SWISS 1	
	1Fr	2Fr	5Fr	-	1/2Fr, 2/3Fr, 3/4Fr, 5/5Fr	SWISS 2	
	1Fr	2Fr	5Fr	-	1/1Fr, 5/5Fr	SWISS 3	
	1Fr	2Fr	5Fr	-	1/1Fr, 2/2Fr, 3/3Fr, 4/4Fr, 6/5Fr ¹	SWISS 4	
	1Fr	1Fr	1Fr	-	1/1Fr (all slots = 1Fr)	SWISS 5	
Belgium	5Fr	20Fr	50Fr	-	1/4x5Fr, 1/20Fr, 3/50Fr ²	BELGIUM	
Belgium 2	5Fr	20Fr	50Fr	-	1/20Fr, 3/60Fr, 3/50Fr-Coin	BELG. BONUS	
Germany	1DM	2DM	5DM	-	1/1DM, 2/2DM, 6/5DM ^{1,2}	GER. 6/5DM	
				-	1/2DM, 2/3DM, 3/4DM, 4/5DM ²	GER. 4/5DM	
				-	1/2DM, 2/3DM, 3/4DM, 5/5DM ²	GER. 1/2DM	
				-	1/1DM, 2/2DM, 5/5DM ²	GER. 1/1DM	
Holland	1G	-	1G	-	1/1G ²	HOLLAND	
Sweden	1Kr	5Kr	10Kr	1Kr	1/10Kr, 2/15Kr, 3/20Kr ^{1,2}	SWEDEN 1	
	1Kr	5Kr	10Kr	1Kr	1/5Kr ²	SWEDEN 2	
France	1Fr	5Fr	10Fr	20Fr	1/3x1Fr, 2/5Fr, 5/10Fr, 10/20Fr ^{2,3}	TARIFF 1	
	1Fr	5Fr	10Fr	20Fr	1/2x1Fr, 3/5Fr, 7/10Fr, 14/20Fr ^{2,3}	TARIFF 2	
	1Fr	5Fr	10Fr	20Fr	1/5Fr, 3/10Fr, 7/2x10Fr, 7/20Fr ^{2,3}	TARIFF 3	
	1Fr	5Fr	10Fr	20Fr	2/5Fr, 4/10Fr, 9/2x10Fr, 9/20Fr ^{2,3}	TARIFF 4	
	1Fr	5Fr	10Fr	20Fr	2/5Fr, 5/10Fr, 11/2x10Fr, 11/20Fr ^{2,3}	TARIFF 5	
	1Fr	5Fr	10Fr	20Fr	1/5Fr, 3/10Fr, 6/20Fr ^{2,3}	TARIFF 6	
Italy	500L	500L	500L	-	1/500L ²	ITALY 1	
	500L	500L	500L	-	1/2x500L, 3/4x500L ^{1,2}	ITALY 2	
	500L	500L	500L	-	1/2x500L, 2/4x500L ²	ITALY 3	
Spain	100P	-	500P	-	1/100P, 6/500P ²	SPAIN	
	25P	-	100P	-	1/25P, 5/100P	CUSTOM	01 00 04 00 01 04 01 00
	25P	-	100P	-	1/25P, 4/100P	CUSTOM	01 00 04 00 01 00 01 00
	25P	-	100P	-	1/2x25P, 2/100P	CUSTOM	01 00 04 00 02 00 01 00
	25P	-	100P	-	1/2x25P, 3/100P	CUSTOM	03 00 12 00 04 00 01 06
Japan	100¥	-	100¥	-	1/100¥ ²	JAPAN	
Chile	Token	-	Token	-	1/1Token ²	CHILE	
Denmark	1Kr	5Kr	10Kr	20Kr	1/2x1 Kr, 3/5 Kr, 7/10 Kr ²	DENMARK 1	
	1Kr	5Kr	10Kr	20Kr	1/5 Kr, 3/10 Kr, 6/20 Kr ^{1,2}	DENMARK 2	
Finland	1Mka	-	5Mka	-	1/2x1Mka, 3/5Mka ²	FINLAND 1	
	1Mka	-	5Mka	-	1/3x1Mka, 2/5Mka ²	FINLAND 2	
New Zealand	\$1.00	-	\$2.00	-	1/\$1, 3/\$2 ²	NEW ZEALAND 1	
	\$2.00	-	\$1.00	-	1/\$1, 3/\$2, (\$2-\$1 door)	NEW ZEALAND 2	
Norway	5Kr	-	10Kr	-	1/5Kr, 2/10Kr, 5/20Kr ²	NORWAY	
Argentina	10¢	10¢	10¢	-	1/1 Token ²	ARGENTINA	
Greece	10D	20D	50D	-	1/2x10D, 1/20D, 3/50D	GREECE	
Antilles	25¢	25¢	1G	-	1/25¢, 4/1G	ANTILLES	
Netherlands 1	1 HFI	2.5 HFI	2.5 HFI	-	1/1HFI, 3/2.5HFI	NETHERLANDS	
Netherlands 2	1 HFI	2.5 HFI	2.5 HFI	-	1/1HFI, 3/3HFI, 3/2.5HFI-Coin	NETH. BONUS	
Netherlands 3	1 HFI	2.5 HFI	5 HFI	-	1/1HFI, 3/2.5HFI	NETH. CSHFL	
Hungary	20 Old	20 New	50F	-	1/40F, 2/60F, 4/100F	HUNGARY	

1. Factory Default. 2. Standard Setting - Change by pressing Enter button. 3. Other functions are also affected. * Only if Bill Acceptor and Center Chute are available.

A.4 HIGH SCORE TO DATE (H.S.T.D.) ADJUSTMENTS

A.4 01 HIGHEST SCORES

The game maintains a record of the four highest scores achieved to date.

OFF - No high scores are recorded, or displayed.

ON - The four highest scores are stored in memory and displayed in Attract Mode.

A.4 02 H.S.T.D. AWARD

This is the award given for achieving the High Score to Date or the Champion High Score to Date. Credit or Ticket

A.4 03 CHAMPION H.S.T.D.

The "Highest" High Score can be displayed in the Attract Mode. This score is not cleared when "High Score Reset Every" occurs.

ON - The "Highest" High Score is retained in memory and displayed.

OFF - The "Highest" High Score is not retained.

A.4 04 CHAMPION CREDITS

The number of credits or tickets awarded for a Grand Champion Score.

Range: 00 to 10.

A.4 05 H.S.T.D. 1 CREDITS

A.4 06 H.S.T.D. 2 CREDITS

A.4 07 H.S.T.D. 3 CREDITS

A.4 08 H.S.T.D. 4 CREDITS

The number of credits or tickets awarded whenever a player exceeds the four highest scores.

Range: 00 to 10.

A.4 09 HIGH SCORE RESET EVERY

The number of games to be played before an automatic reset of the displayed Highest Score occurs. The operator selects the values provided at reset in the Back-up High Scores.

Range: OFF (disabled), 250 to 20,000.

A.4 10 BACKUP CHAMPION

The Back-up Grand Champion Score.

Range: 00 to 200,000,000

A.4 11 BACKUP H.S.T.D. 1

A.4 12 BACKUP H.S.T.D. 2

A.4 13 BACKUP H.S.T.D. 3

A.4 14 BACKUP H.S.T.D. 4

The first through fourth Back-up High Score values. The game automatically restores this value when the "High Score Reset Every" value is reached.

Range: 00 to 200,000,000

A.4 15 MONSTER BASH CHAMPION

This adjustment is used to set the score to be achieved during the Monster Bash feature to become the new Monster Bash Champion.

Range: 10,000,000 to 60,000,000

A.4 16 MONSTER BASH CREDITS

This adjustment specifies the number of credits to award the new Monster Bash Champion at the end of a game.

Range: 00-03

A.4 17 MONSTERS OF ROCK CHAMPION

This adjustment is used to set the score to be achieved during the Monsters of Rock feature to become the new Monsters of Rock Champion.

Range: 50,000,000 to 90,000,000

A.4 18 MONSTERS OF ROCK CREDITS

This adjustment specifies the number of credits to award the new Monsters of Rock Champion at the end of a game.

Range: 00-03

A.5 PRINTER ADJUSTMENTS (optional board required)

A.5 01 COLUMN WIDTH

The column width to be printed. Range: 22 to 80.

A.5 02 LINES PER PAGE

This is the amount of lines per page. Range: 20 to 80.

A.5 03 PAUSE EVERY PAGE

Choose whether the printer pauses at the end of a page.

- YES - The printer does pause.
- NO - The printer doesn't pause.

A.5 04 PRINTER TYPE

Select the type of printer: Parallel, Serial, ADP, Mini-Drucker, or NSM.

A.5 05 SERIAL BAUD RATE

Select which baud rate to use for serial or ADP communications (bit rate): 300, 600, 1200, 2400, 4800, or 9600.

A.5 06 SERIAL D.T.R. (DATA TERMINAL READY)

When a serial printer is used, this line may be connected to a printer output line signaling that the printer is busy.

- NORMAL - Normal D.T.R. signal goes low to indicate the printer is not ready.
- INVERTED - Inverted D.T.R. (busy) signal goes high to indicate the printer is not ready.
- IGNORE - D.T.R. signal is ignored.

A.5 07 AUTO PRINTOUT

With the optional printer board installed, this adjustment allows the initiation of printouts whenever the game detects a printer connected to the game. Parallel printers are detected automatically by plugging them in and putting them on-line. Serial printers (or computers) are detected by sending a carriage return (ASCII 0x0D) or XON (ASCII 0x11).

This adjustment has the following settings:

OFF	Disable automatic printouts
MAIN AUDITS	Main Audit Table (B.1)
EARNINGS	Earning Audits (B.2)
STD. AUDITS	Standard Audits (B.3)
FEATURES	Feature Audits (B.4)
HISTOGRAMS	Histograms (B.5)
TIMESTAMPS	Time Stamps (B.6)
ALL DATA	All of the above data

The table specified above will automatically be printed when a printer (or computer) is detected.

If the printer is detected during game over or test mode, the printout will be taken right away.

If the printer is connected while a game is being played, it will take up to 10 seconds to be detected, after which the printout will occur. The game will resume after the printout is complete.

Automatic printouts will only take place if the coin door is open.

After an automatic printout has been generated, a 2nd automatic printout will not be possible until a new game has started, or test mode begins.

ERROR MESSAGES

The WPC-95 game program has the capability to aid the operator and service personnel. At game turn-on, or after pressing the Begin Test switch, once the game has been operating for an extended period, the display may signal with a message, "Press ENTER for Test Report". This indicates the game program has detected a possible problem with the game.

MONSTER BASH features a new coin door display. When the coin door is open (in Attract mode and game play), the display shows that the high-power has been disabled. It also shows the Test Report (if there is anything to report), and some game specific information. Use the flipper buttons to page through this information.

To obtain details of the problem open the coin door and press the Begin Test switch. Press the Enter button to begin displaying the message(s). The following messages apply to your game.

GAME SPECIFIC ERROR MESSAGES.

CHECK LEFT GATE - STUCK CLOSED.

The game has detected that the Left Gate is stuck closed. Use T.16 (Loop/Gate Test), Loops Mode, to verify that all of the Loop switches and the Left Gate are operating properly.

CHECK LEFT GATE - STUCK OPEN.

The game has detected that the Left Gate is stuck open. Use T.16 (Loop/Gate Test), Jets Mode, to verify that the Right Loop switches and the Left Gate are operating properly.

CHECK RIGHT GATE - STUCK CLOSED.

The game has detected that the Right Gate is stuck closed. Use T.16 (Loop/Gate Test), Loops Mode, to verify that all of the Loop switches and the Right Gate are operating properly.

CHECK RIGHT GATE - STUCK OPEN.

The game has detected that the Right Gate is stuck open. Use T.16 (Loop/Gate Test), Jets Mode, to verify that the Left Loop switches and the Right Gate are operating properly.

GENERAL ERROR MESSAGES.

CHECK SWITCH ##

This message indicates that at least one switch was stuck 'On' at game turn-on or has NOT been actuated during ball play (for 90 balls or apx. 30 games). The game program compensates the game play requirements affected by each disabled switch to allow 'nearly normal' play. This helps keep your game earning, until the service technician can repair the problem. To verify the problem, refer to the Test Menu text describing Switch Testing, and check each reported switch using applicable switch tests. Always check switch operation using a ball, to simulate game conditions. Switch problems may often be resolved by adjusting the wire switch actuators, fixing switch circuitry problems, securing loose connectors, etc. Mechanisms using 'opto switches' (drop targets, etc.) need to be checked for proper power connections (+12V dc and ground).

CHECK FUSES F115 AND F116 AND OPTO 12V SUPPLY

This message will be displayed if the game senses that all optical switches are not functioning. This usually occurs when there is no +12V supply to the playfield optics.

The problem is likely to be a blown fuse (F109), or at connectors J138, J139, J140 or J141 on the power driver board.

OPTO TROUGH BAD CHECK CONNECTORS, WIRES AND 12V SUPPLY

This message will be displayed if all of the opto switches in the playfield ball trough are not functioning. This is usually caused by a problem with a ball trough connector supplying +12V and ground for the optical circuits.

PINBALL MISSING

This game normally uses four balls, however, it will operate with less. This message announces that a ball is missing or stuck. When the ball is located, return it to the game via the Outhole. Other possibilities for this problem could be malfunctions of the Ball Trough switches or the Ball Shooter switch.

XXXX SW. IS STUCK ON

This message indicates that a switch, which is not usually on, remains in the On position after. The stuck switch is essential for game play (for example, a coin chute switch, the slam tilt switch, and the plumb bob tilt switch), and should be cleared to permit proper game operation.

GROUND SHORT ROW - N, WHT - XXX

This message indicates that the switch wires being called out are touching a grounded part on the playfield or coin door. The following should be checked:

1. Slam tilt (or other coin door switch) touching the grounded coin door.
2. A leaf-type, playfield switch touching a grounded part.
3. Players poking metallic objects (wires, coat hangers, etc.) into the game.
4. Switch cable insulation pierced or damaged allowing bare wire contact with a grounded part.
5. All switches in a row closing at the same time. **Note:** This is NOT a switch problem; however, for most games this is a very rare possibility.

G10 ERROR

The security chip is incorrect or faulty. If this occurs, replace the security chip.

G11 CHECKSUM ERROR

The game ROM checksum is invalid. If this occurs replace the game ROM.

TIME AND DATE NOT SET.

The real time clock is not set. Go to U.4 of the Utilities Menu and set the time and date.

FACTORY SETTINGS RESTORED.

This message indicates that the CMOS RAM (U8) no longer retains any custom Pricing or Game Adjustment settings and has reverted to factory default settings. Generally, the following CPU checks will isolate the cause of the CMOS RAM memory failure. The voltages at pin 28 and pin 26 of U8 should be +5V (game turned On) and at least +4V (game turned Off). When the voltage drops below +4V, memory reset occurs. Check the batteries and battery holder. Be sure that the batteries are good and that there is no contamination on the battery holder terminals. Turn the game OFF, and use an ohmmeter to check diodes D1 and D2 on the CPU Board. D1 should read 0 ohms when forward-biased and infinite ohms when reverse-biased. D2 should read 15 ohms when forward-biased and infinite ohms when reverse-biased. (Readings taken with an analog meter.) This message can also indicate that there is an open diode on a 50V-coil circuit and noise is entering the circuit.

CPU AND AUDIO/VISUAL BOARD ERROR CODES

The CPU has three LED's, 201, 202, and 203. At game turn-on LED 201 and LED 202 are on, LED 203 is off. During normal operation LED 201 is off, LED 202 is on, and LED 203 is flashing. If the system detects an error the following happens:

CPU board error codes

<u>Center LED blinks once</u>	<u>= G11 ROM Failure</u>
<u>Center LED blinks twice</u>	<u>= U8 RAM Failure</u>
<u>Center LED blinks three times</u>	<u>= G10 Security Chip Failure</u>

The Audio/Visual board produces one beep upon game turn on if the board is operating properly. If the system detects an error the following happens:

CPU and Audio/Visual Board Error Codes Continued...

Audio/Visual board error codes

1 Beep	= Audio/Visual Board is O.K.
2 Beeps	= S2 Failure
3 Beeps	= S3 Failure
4 Beeps	= S4 Failure
5 Beeps	= S5 Failure
6 Beeps	= S6 Failure
7 Beeps	= S7 Failure
10 Beeps	= Audio Static RAM Failure

OPTO THEORY

The opto receiver (Photo Transistor) should be approximately 0.1 - 0.7 volts when the opto beam is unblocked and approximately 11 - 13 volts when the opto beam is blocked. The opto transmitter (LED) should always be approximately 1.4 volts.

Note: The transmitter (LED) is larger than the receiver (Photo Transistor); it protrudes further from its case.

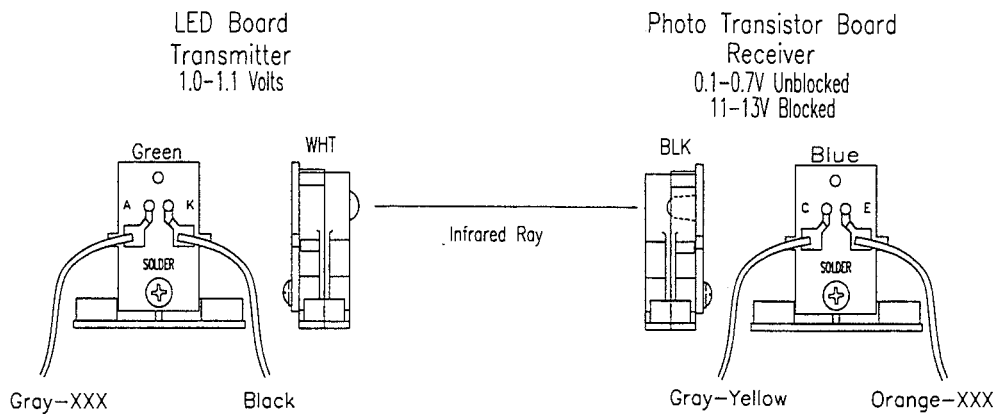

LED LIST

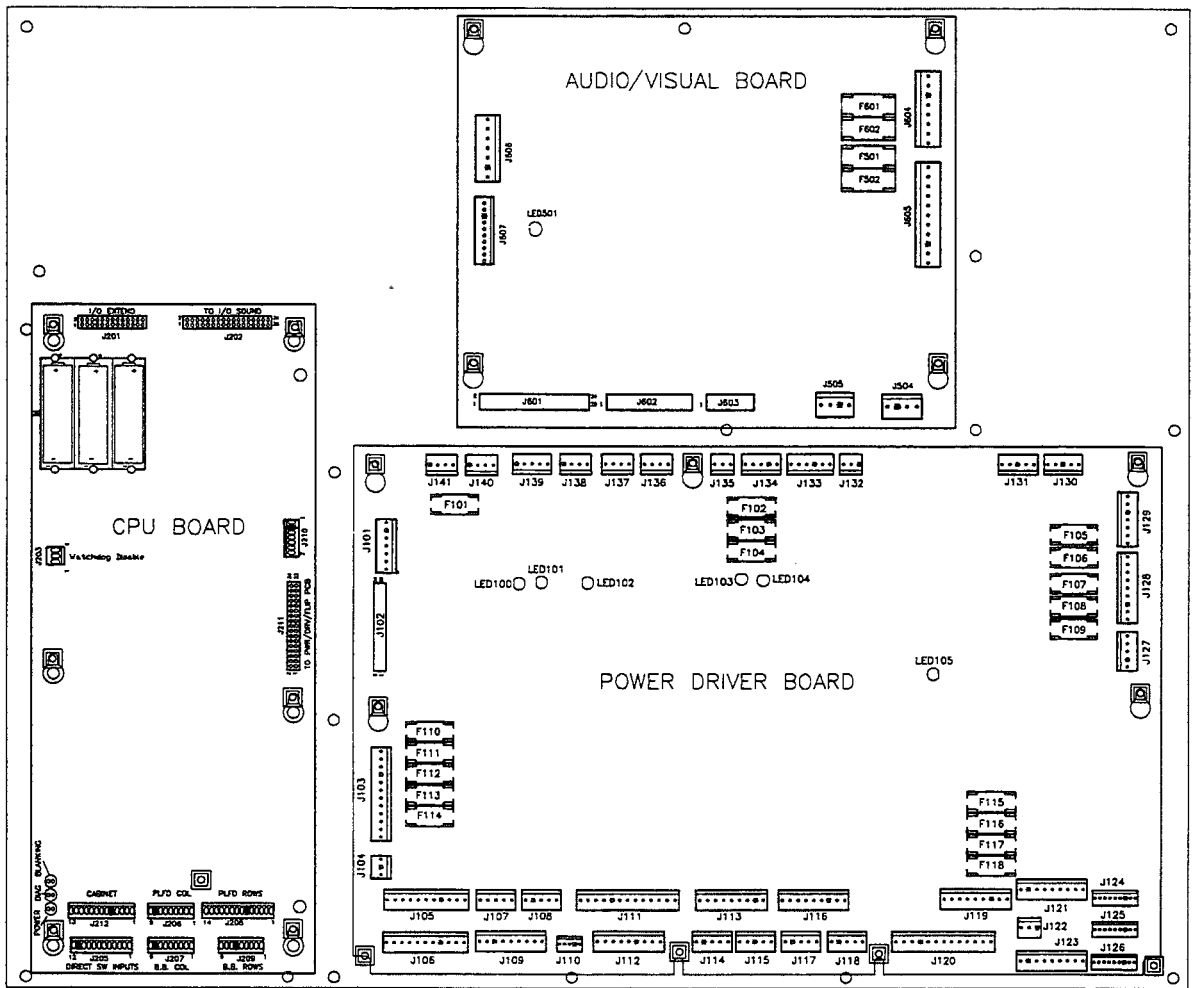

CPU BOARD

- LED 201 Blanking
- LED 202 Power
- LED 203 Diagnostics

At game turn-on, LED 201 and LED 202 are on, LED 203 is off. During normal operation LED 201 is off, LED 202 is on, and LED 203 is flashing.

AUDIO/VISUAL BOARD

- LED 501 +5VDC, Normally flashing, but at a slower rate than LED 203.

POWER DRIVER BOARD

- LED 100 +12VDC Regulated, Normally On
- LED 101 +5VDC Digital, Normally On
- LED 102 +18VDC Lamps, Normally On
- LED 103 +12VDC Unregulated, Normally On
- LED 104 +20VDC Flashlamps, Normally On
- LED 105 +50VDC Coils, Normally On

FUSE LIST

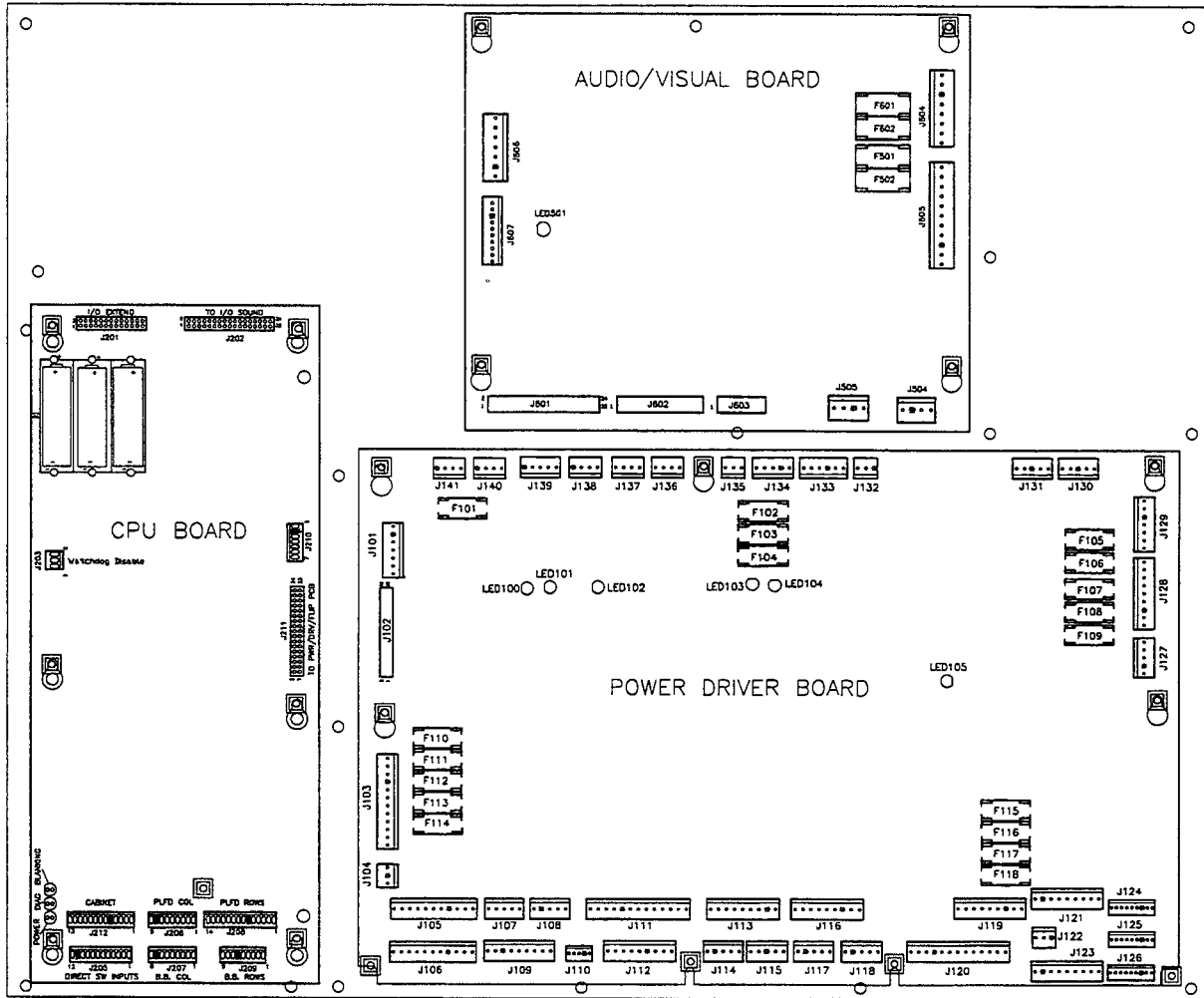

AUDIO/VIDEO BOARD

Loc.	Description	Part Number	Value
F501	-25V	5731-14532-00	T2.5A, 250V
F502	+25V	5731-14532-00	T2.5A, 250V
F601	+62V	5731-14840-00	T0.315A, 250V
F602	-113V & -125V	5731-14840-00	T0.315A, 250V

CPU BOARD

There are no fuses on the CPU board.

POWER DRIVER BOARD

Loc.	Description	Part Number	Value	Loc.	Description	Part Number	Value
F101	Regulated 12V	5731-14531-00	T0.63A, 250V	F110	G.I. #5 WHT-VIO	5731-14530-00	T4.0A, 250V
F102	Solenoid. #25 to #28	5731-14530-00	T4.0A, 250V	F111	G.I. #4 WHT-GRN	5731-14530-00	T4.0A, 250V
F103	Solenoid #1-#8	5731-14530-00	T4.0A, 250V	F112	G.I. #3 WHT-YEL	5731-14530-00	T4.0A, 250V
F104	Solenoid #9 to #16	5731-14530-00	T4.0A, 250V	F113	G.I. #2 WHT-ORG	5731-14530-00	T4.0A, 250V
F105	+5V Logic	5731-14530-00	T4.0A, 250V	F114	G.I. #1 WHT-BRN	5731-14530-00	T4.0A, 250V
F106	+18V Lamp Matrix	5731-14046-00	T5.0A, 250V	F115	+50V Flippers	5731-14530-00	T4.0A, 250V
F107	Flasher Secondary	5731-14530-00	T4.0A, 250V	F116	+50V Flippers	5731-14530-00	T4.0A, 250V
F108	Solenoid Secondary	5731-14529-00	T6.3A, 250	F117	+50V Flippers	5731-14530-00	T4.0A, 250V
F109	Unregulated 12V	5731-14530-00	T4.0A, 250V	F118	+50V Flippers	5731-14530-00	T4.0A, 250V

LINE FILTER

Loc.	Part Number	Value
Foreign	5731-14530-00	T4.0A, 250V
Domestic	5731-14046-00	T5.0A, 250V

MAINTENANCE INFORMATION

LUBRICATION

The two main lubrication points of the Ball Release mechanism are the pivots for the arm. The mechanisms of other playfield devices are somewhat similar to the Ball Release device, and have the same lubrication requirements. A medium viscosity oil (switch target grease) is satisfactory for these devices.

Because of the functional design (arm-actuated via solenoid plunger operation), the pivot points of the Left and Right Kickers ("Slingshots") all require lubrication as a regular servicing procedure.

Lubrication to ensure proper operation also applies to the target blades of the Drop Targets. MBI Instrument Grease, also known as Drop Target Switch Lubricant, with a Williams' part number of EI165, is a recommended lubricant.

SWITCH CONTACTS

Playfield Switches

For proper game operation, switch contacts should be free of dust, dirt, contamination, and corrosion. Blade switch contacts are plated to resist corrosion. Cleaning blade switch contacts requires gentle closing of the contacts on a clean business card or piece of paper, and then pulling the paper about 2 inches, which should restore the clean contact surface. Adjust the switch contacts to a 1/16-inch gap.

Flipper Switches

This game uses the new Fliptronic II Electronic Flipper System. The End-of-Stroke switches are NORMALLY OPEN. The switch should close when the flipper is energized. All E.O.S. switches are gold flashed computer grade leaf switches. Only low computer current is carried through these switches. DO NOT FILE or abrasively clean these switches! DO NOT REPLACE these switches with the tungsten high current switches, as intermittent operation could occur.

Note: Unlike the old style of flipper, an E.O.S. switch failure does not harm the flipper. The game notifies the operator that the switch is misadjusted in the test report, but continues to play. The E.O.S. switches are a means by which the new electronic flippers feel and play with all of the subtleties of the old flippers.

CLEANING

Good game action and extended playfield life are the results of regular playfield cleaning. During each collection stop, the playfield glass should be removed and thoroughly cleaned and the playfield should be wiped off with a clean, lint-free cloth. The game balls should be cleaned and inspected for any chips, nicks, or pits. Replace any damaged balls to prevent playfield damage.

Regular, more extensive, playfield cleaning is recommended. However, avoid excessive use of water and caustic or abrasive cleaners because they tend to damage the playfield surface. Playfield wax (or any carnauba based wax), or polish may be used sparingly, to prevent a buildup on the playfield surface. Do not use cleaners containing petroleum distillates on any playfield plastics because they may dissolve the plastic material or damage the artwork.

SECTION TWO

PARTS INFORMATION

50065-BB Backbox Assembly

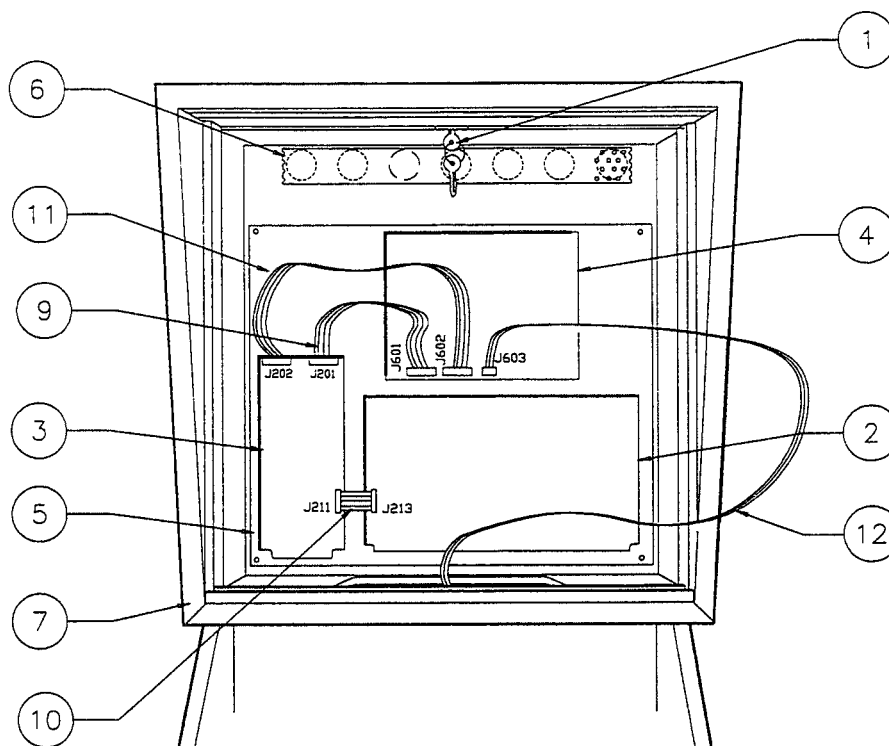

Item	Part Number	Description	Miscellaneous Parts: (Not Shown)	
			Part Number	Description
1	A-21998	Lock & Plate Assembly	01-8397	Bracket Trunk Latch
a)	20-10462	Lock & Cam Kit	02-5223	Button Speaker Panel (4)
2	A-20028	WPC '95 Power Driver PCB		
3	A-21377-50065	WPC '95 CPU PCB Assy.		
4	A-20516-50065	WPC '95 Audio Visual PCB Assy.		
5	A-14092-7	Mounting Plate Assembly		
6	01-6645	Vent Screen		
7	04-11038	Wood Backbox		
*8	A-21559	Speaker/Display Assembly		
Ribbon Cables:			Cables:	
9	5795-12653-15	Ribbon Cable, 34-Pin, 2 Conn.	H-20477	Logic Power Cable
10	5795-12653-03	Ribbon Cable, 34-Pin, 3"	H-20478	Secondary Cable
11	5795-10938-19	Ribbon Cable, 26-Pin, 2 Conn.	H-20479	Dot Matrix Power Cable
12	5795-13434-25	Ribbon Cable, 14 Pin w/Ferrite	H-22725	Insert Cable

* Not Shown.

50065-CAB Cabinet Assembly

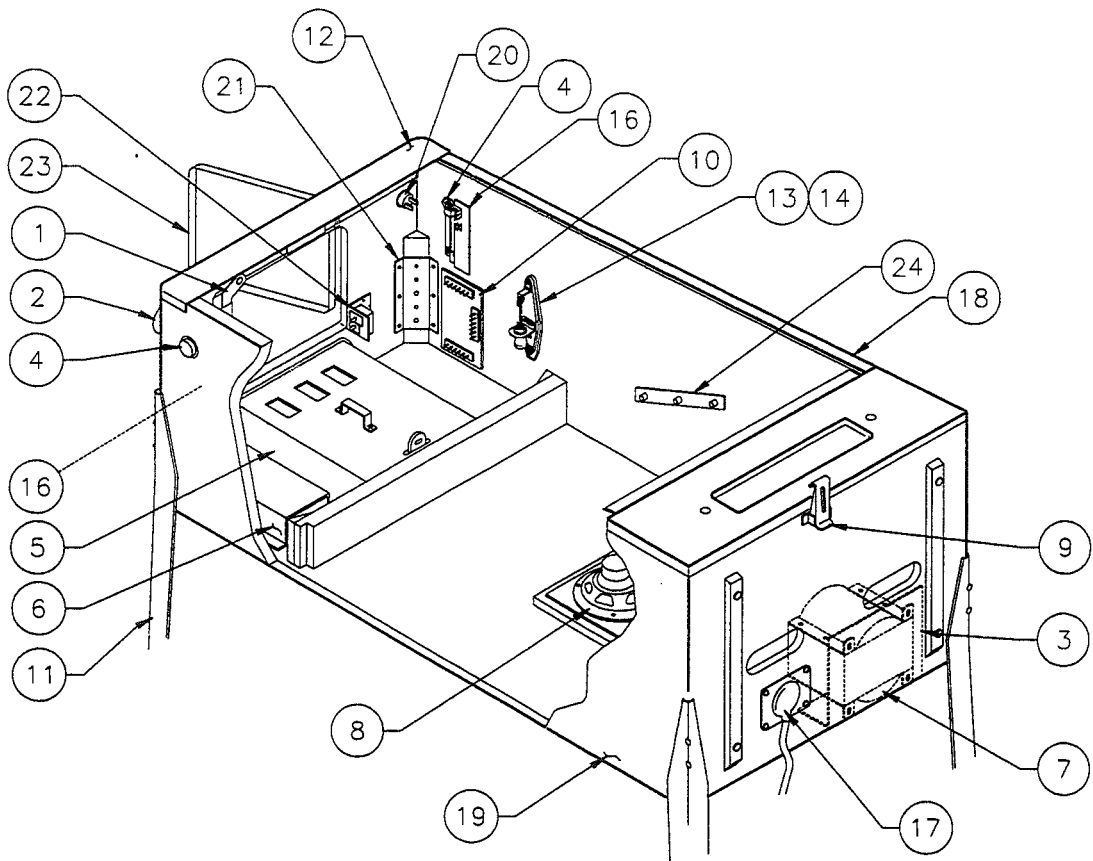

Item	Part Number	Description
1	A-16773-1	Lever Guide Assembly
2	20-9663-B-4	Large Round Push Button
3	01-13936	Drip Plate – Narrow
4	A-16883-6	Flipper Button w/Spring (2)
5	A-20729-5	4-Ball Cashbox Assembly
6	A-20731	Power Interface Assy.
7	5610-14515-01	WPC Transformer
8	5555-12929-00	Speaker, 4Ω, 6", 25w
9	20-9347	Toggle Latch
10	A-20580	Coin Door Interface Board
11	A-19514	Leg Assembly, Chrome (4)
12	D-12615	Front Molding Assembly
13	20-6502-A	Plumb Bob
14	04-10346	Tilt Mechanism Assembly
15	*	Cordset
16	A-17316	Opto Flipper Assembly (2)
17	01-10714	Line Cord Cover
18	A-12359-3	Side Molding Assembly (2)
19	11-1458	Wood Cabinet
20	20-9663-16	Push Button w/Sw., <i>Start</i> (Yellow)
21	01-11400	Leg Plate (4)
22	A-18249-3	Cable & Interlock Switch Assy.
23	09-61000-1	Coin Door-U.S.A.
24	01-11408	Plate Spacer (2)

Miscellaneous Parts: (Not Shown)

A-17195	Tilt Switch Assy. w/Cable
A-19562.1	Stay Arm Assembly
01-12352	Clip Bracket
01-9011.2-L	Backbox Mtg. Bracket, Left
01-9011.2-R	Backbox Mtg. Bracket, Right
01-6389-1	Cashbox Lock Bracket
08-7028-T	Playfield Glass
08-7377	Leg Leveler Adjuster, 3"
20-6500	Steel Ball, 1-1/16" (4)

Cabinet Cables:

A-20201	Cable & Jumper Assy., Coin Door
H-17217.1	Plumb/Bob Mech. Protect Cable
H-17837-2	Voltage Program Jumper Cable
H-20599-1.1	WPC '95 Cabinet Cable
H-19601-1	Power Extension Cable
H-21838	Cabinet Sw/Lamp Cable

* See Power Interface/Cordset Application Chart on page 2-37.

A-20516-50065 WPC '95 Audio Visual PCB Assembly

Part Number	Designator	Description	Part Number	Designator	Description
4004-01005-06	-	Mach. Screw, 4-40 x 3/8"	5048-13610-00	C8, C10, C11, C13, C14	Cap., 1000pf, 50v, 5% Ax.
4404-01119-00	-	Nut 4-40 ESN	5048-13611-00	C16, C17, C20, C21	Cap., 680pf, 50v, 5% Ax.
5010-08774-00	R2, R17, R22, R23, R35, R36, R40, R42, R87	Resistor, 22K Ω , 1/4w, 5%	5048-14563-00	C29-C31, C81, C82	Cap., .01 μ f, 200v, 10% Axial
5010-08991-00	R20, R46-R48, R50, R72, R76, R77, R81, R107	Resistor, 4.7K Ω , 1/4w, 5%	D19-D22	D19-D22	Diode MR501, 3.0A
5010-09034-00	R21	Resistor, 10K Ω , 1/4w, 5%	5070-09054-00	D4, D6-D17, D23	Diode 1N4004, 1.0A
5010-09036-00	R19	Resistor, 100 Ω , 1/4w, 5%	5075-12823-00	D1, D18	Zener, 1N4758A 56v, 1w
5010-09134-00	R32-R34	Resistor, 150K Ω , 1/4w, 5%	5075-12824-00	D3, D5	Zener, 1N4742A 12v, 1w
5010-09219-00	R1, R3	Resistor, 8.2K Ω , 1/4w, 5%	5075-12826-00	D2	Zener, 1N4759, 62v, 1w
5010-09416-00	R73, R74, R82, R88, R105, R106	Resistor, 470 Ω , 1/4w, 5%	5160-08938-00	Q13-Q15	Transistor, 2N4401 NPN
5010-09807-00	R30, R31, R67-R69, R102	Resistor, 120 Ω , 1/4w, 5%	5164-09056-00	Q2, Q3	Transistor, MPSD02 NPN
5010-10171-00	R24	Resistor, 56 Ω , 1/4w, 5%	5164-12154-00	Q1, Q7	Transistor, MJE15030 NPN
5010-10258-00	R86	Resistor, 1M Ω , 1/4w, 5%	5194-09055-00	Q4, Q5	Transistor, MPSD52 PNP
5010-10983-00	R53, R75, R79, R84, R85, R89, R90	Resistor, 1.8K Ω , 1/4w, 5%	5194-12155-00	Q6	Transistor, MJE15031 PNP
5010-12832-00	R25, R26, R27, R29	Resistor, 47K Ω , 1/4w, 5%	5250-13302-00	U7	Reg. 78L05T 5v
5010-13215-00	R78, R97-R101	Resistor, 200K Ω , 1/4w, 5%	5250-13303-00	U8	Reg. 79L05T 5v
5010-13372-00	R91-R96, R103, R104	Resistor, 220 Ω , 1/8w, 5%	5311-12538-00	U4	IC 74HC14 Hex. S-T
5010-13420-00	R37, R41	Resistor, 680 Ω , 1/4w, 5%	5317-12211-00	U12-U14	IC Octal Buffer 74ALS541
5010-13517-00	R38, R39	Resistor, 15 Ω , 1/4w, 5%	5340-12278-00	U25	S/Ram 2064 150NS
5010-13607-00	R4, R5, R7-R15	Resistor, 6.19K Ω , 1/8w, 1%	5370-12687-00	U27	IC MC 340640Reset Chp
5012-14558-00	R44	Resistor, 1.8K Ω , 5w vertical	5349-14351-00	U9-U11	SRAm 8Kx8-35ms, 28pdip
5012-14559-00	R43	Resistor, 4.7K Ω , 5w vertical	5370-12730-00	U1, U2	IC Op Amp TL084
5012-14560-00	R28	Resistor, 120 Ω , 5w vertical	5370-13419-00	U5, U6	IC TDA 2030AV 18w, Audio Amp
5013-13661-00	R16	Resistor, 9.09K Ω , 1/4w, 1%	5371-13299-00	U3	IC Ad-1851 16bit mono
5013-14456-00	R6, R18	Resistor, 3.32K Ω , 1/4w, 1%	5410-14705-00	U26	IC Custom WPC AV Asic 120PQFP
5040-14569-00	C35	Cap., 100mf, 25v, Axial	5400-13298-00	U21	IC MPU 210kp-40 ADSP
5040-09365-00	C38, C39, C43, C44	Cap., 1m, 63v(+50,-10%)Ax.	5520-14561-00	X2	Crystal 20mHz, parallel 20pf
5040-12750-00	C48, C52, C73	Cap., 22m, 35v Radial	5671-14516-00	LED 501	Led-Display Red T 1-3/4
5040-13098-00	C18, C67, C68	Cap., 4.7 μ , 35v (\pm 20%)	5700-08985-00	U24	Socket IC 40-pin .6
5040-15413-00	C36, C37	Cap., 10000 μ f, 35v, 25mm	5700-12047-00	U22	Socket IC 24.3P
5040-14564-00	C28, C42	Cap., 150 μ f, 160v, 20%Rad.	5700-12088-00	S2-S7	Socket Dip 32.6P"
5043-08996-00	C2, C3, C19, C22- C24, C26, C32, C34, C45, C46, C49, C50, C53-C66, C69, C72, C74-C76, C79, C80	Cap., 0.1 μ f, 50v (\pm 20%) Ax.	5705-12638-00	U5, U6	Heatsink 5298B
5048-10992-00	C27	Cap., .0047m, 50v, 10% Ax.	5705-14562-00	Q1, Q6, Q7	Heatsink 10-220 wave sol 287
5048-11028-00	C77	Cap., 22p, 50v, Axial	5733-14528-00	F501, F502, F601, F602	Fuse Holder 5x20mm 10A.
5048-11029-00	C25	Cap., 100p, 50v, 5% Axial	5731-14532-00	F501, F502	Fuse 5x20mm T2.5A., 250V
5048-11030-00	C7	Cap., 470p, 50v, Axial	5731-14840-00	F601, F602	Fuse 5x20mm T0.315A., 250V
5048-11033-00	C1	Cap., .022m, 50v, 10% Ax.	5791-10850-00	J602	Connector, 26-pin Header Str.
5048-12036-00	C40, C41	Cap., .22m, 50v, Axial	5791-10862-04	J504, J505	Connector, 4-pin Header Str.
5048-13172-00	C78	Cap., 47pf, 50v, 20% Ax.	5791-10862-07	J606	Connector, 7-pin Header Str.
5048-13418-00	C4 - C6	Cap., .047m, 50v, 5% Ax.	5791-10862-08	J604	Connector, 8-pin Header Str.
5048-13609-00	C9, C12, C15	Cap., 3900pf, 50v, 5% Ax.	5791-10862-11	J605	Connector, 11-pin Header Str.
			5791-12516-00	J601	Connector, 34 hdr 2 x 17 .100
			5791-12827-00	J603	Connector, 14 Hen 7x2 Str.
			5791-13830-10	J607	Connector, 10-pin Str. Sq.
			5010-09534-00	W0, W1, W12-W17, R49	Resistor, 0 Ω , 0w
			A-5343-50065-S2	S2	ROM Assembly
			A-5343-50065-S3	S3	ROM Assembly
			A-5343-50065-S4	S4	ROM Assembly
			A-5343-50065-S5	S5	ROM Assembly
			A-5343-50065-S6	S6	ROM Assembly
			A-5343-50065-S7	S7	ROM Assembly

A-20516-50065 WPC '95 Audio Visual PCB Assembly

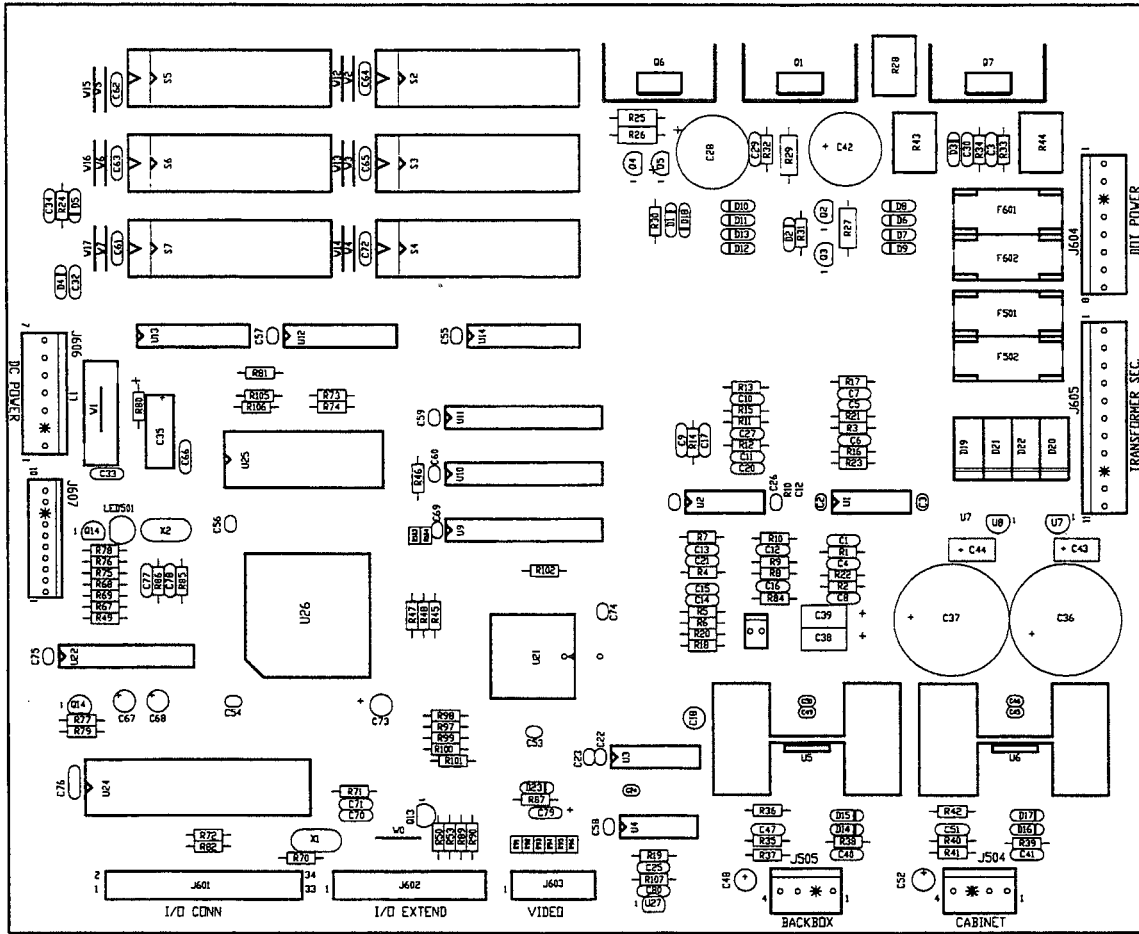

A-20028 WPC '95 Power Driver PCB Assembly

Part Number	Designator	Description	Part Number	Designator	Description
5040-14569-00	C1, C40	Capacitor, 100µF, 25v, Ax.	5010-09999-00	R3, R4, R6-R8, R43, R44, R81-R83, R190	Resistor, 2KΩ, 1/4w, 5%
5043-08996-00	C2, C4, C5, C7, C13, C16-C21, C24-C39, C41-C43	Capacitor, 0.1m, 50v (±20%) Ax.	5012-12632-00	R9	Resistor, .12Ω, 10w, 5%
5040-13417-00	C8 - C12	Capacitor, 10000µf, 35v Radial	5010-09324-00	R10	Resistor, 27KΩ, 1/4w, 5%
5048-11031-00	C14, C15	Capacitor, .001m, 50v, 10% Ax.	5010-09358-00	R11, R157, R159, R161, R163, R165, R167, R169, R171, R216-R224	Resistor, 1KΩ, 1/4w, 5%
5040-09537-00	C22, C23	Capacitor, 100µ, 100v (±20%) Radial	5010-09036-00	R247	Resistor, 100Ω, 1/4w, 5%
5070-09054-00	D1, D2, D23, D24, D33 - D100, D103 D3-D22	Diode 1N4004 1.0A.	5010-09034-00	R12, R13, R189, R208-R215, R248	Resistor, 10KΩ, 1/4w, 5%
5070-14526-00	D101, D102	Diode P600G 6A 400 PIV	5010-08992-00	R18, R21, R24, R192, R194, R196, R198, R200, R202, R204, R206	Resistor, 560Ω, 1/4w, 5%
5070-08919-00	F101	Diode, 1N4148 150mA.	5010-08991-00	R19, R22, R25, R28, R30, R32, R34, R50, R52, R54, R56, R58, R60, R62, R64, R84, R86, R88, R90, R92, R94, R96, R98, R116, R119, R122, R125, R128, R131, R134, R137, R246	Resistor, 4.7KΩ, 1/4w, 5%
5731-14531-00	F102-F105, F107, F109-F118	Fuse 5 x 20mm T.63A., 250V	5010-11079-00	R20, R23, R26, R254-R256	Resistor, 51Ω, 1/4w, 5%
5731-14046-00	F106	Fuse 5 x 20mm T.63A., 250V	5010-09416-00	R27, R29, R31, R33, R45-R49, R51, R53, R55, R57, R59, R61, R63, R85, R87, R89, R91, R93, R95, R97, R99, R117, R120, R123, R126, R129, R132, R135, R138, R156, R158, R160, R162, R164, R166, R168, R170, R245, R250-R253, R257	Resistor, 470Ω, 1/4w, 5%
5731-14529-00	F108	Fuse 5 x 20mm T6.3A, 250V	5010-08993-00	R35, R37, R39, R41, R65-R72, R100-R107, R140-R147	Resistor, 68Ω, 1/4w, 5%
5733-14528-00	F101-F118	Fuse Holder 5 x 20mm10A	5010-08997-00	R36, R38, R40, R42, R73-R80, R108, R109, R110-R115, R118, R121, R124, R127, R130, R133, R136, R139	Resistor, 2.7kΩ, 1/4w, 5%
5705-14724-00	Q1	Heat Sink TO-3 5.1DEG/W	5010-09361-00	R148-R155, R184-R187	Resistor, 220Ω, 1/4w, 5%
5701-09652-00	Q1	Thermal Pad TO-3	5011-12956-00	R172, R173, R178-R183	Resistor, 2.7KΩ, 1/4w, 5%
4406-01128-00	Q1	Nut 6-32 KEPS	5010-10171-00	R174-R177, R241-R244	Resistor, 56Ω, 1/4w, 5%
4006-01005-06	Q1	Mach. Screw, 6-32 x 3/8"	5010-14711-00	R188	Resistor, 10KΩ, 1/4w, 5%
5705-14562-00	Q2	Heat Sink 10-220 Wave Sol 287	5010-09314-00	R191, R193, R195, R197, R199, R201, R203, R205	Resistor, 1.2kΩ, 1/4w, 5%
4004-01005-06	Q2-Q5	Mach. Screw, 4-40 x 3/8"	5010-09086-00	R207	Resistor, 6.8kΩ, 1/4w, 5%
4404-01119-00	Q2-Q5	Nut 4-40 ESN	5010-12427-00	R225, R228, R231, R234, R237-R240	Resistor, .22kΩ, 1/4w, 5%
5705-12638-00	Q3-Q5	Heat Sink 5298B	5010-08998-00	R226, R227, R229, R230, R232, R233, R235, R236	Resistor, 2.2kΩ, 1/4w, 5%
5791-10862-07	J101, J129	Connector, 7-pin Header Str.	5010-13517-00	R249	Resistor, 150Ω, 1/4w, 5%
5791-12516-00	J102	Connector, 34 Hdr 2x17	5010-09534-00	D25-D32	Resistor, 0Ω, 0w
5791-10862-12	J103	Connector, 12-pin Header Str.	5019-10143-00	SRI	SIP RES 470 x 9R
5791-10862-03	J104, J122, J132, J135	Connector, 3-pin Header Str.	5824-09248-00	TP100-TP107	Test Point #1502-1
5791-10862-11	J105, J106	Connector, 11-pin Header Str.	5370-12272-00	U1, U16, U17	I.C. LM339 Quad Comp
5791-10862-05	J107, J108, J114, J115, J117, J118, J127, J130, J131, J134, J139	Connector, 5-pin Header Str.	5281-09486-00	U2, U4-U8, U10	I.C. 74LS374 8dff
5791-10862-09	J109, J112, J113, J116, J119, J121, J123, J128	Connector, 9-pin Header Str.	5162-12422-00	U3, U11	Trans uln 2803 Oc-drl
5791-10862-13	J111, J120	Connector, 13-pin Header Str.	5281-10182-00	U9	I.C. 74LS240 l/dvrr
5791-13830-09	J124-J126	Connector, 9-pin Header Str.	5791-13830-05	J110	Connector, 5-pin Header
5791-10862-06	J133	Connector, 6-pin Header Str.			
5791-10862-04	J136-J138, J140, J141	Connector, 4-pin Header Str.			
5671-14516-00	LED100-LED105	LED Dspl Red T-1			
5250-14527-00	Q1	Regulator Voltage LM317K			
5460-12423-00	Q2	I.C. LM7812			
5131-12725-00	Q3-Q5	Triac 4 Quad Low Gate Current			
5194-09055-00	Q6-Q12, Q17-Q24, Q33-Q40, Q49-Q56, Q109	Transistor, MPSD52 PNP			
5162-12635-00	Q13-Q16, Q25-Q32, Q41-Q48, Q57-Q64, Q82, Q83, Q85, Q86, Q88, Q89, Q91, Q92, Q101-Q108	Transistor, TIP102			
5191-12179-00	Q65-Q72, Q81, Q84, Q87, Q90	Transistor, TIP36C			
5190-09016-00	Q73 - Q80	Transistor, 2N4403 PNP			
5192-12428-00	Q93 - Q100	Transistor, TIP107			
5160-10269-00	Q110	Transistor, 2N3904			
5013-14535-00	R1	Resistor, 750Ω, 1/4w, 1%			
5013-14534-00	R2	Resistor, 243Ω, 1/4w, 1%			
5010-09224-00	R5, R14-R17	Resistor, 270Ω, 1/4w, 1%			

A-20028 WPC '95 Power Driver PCB Assembly

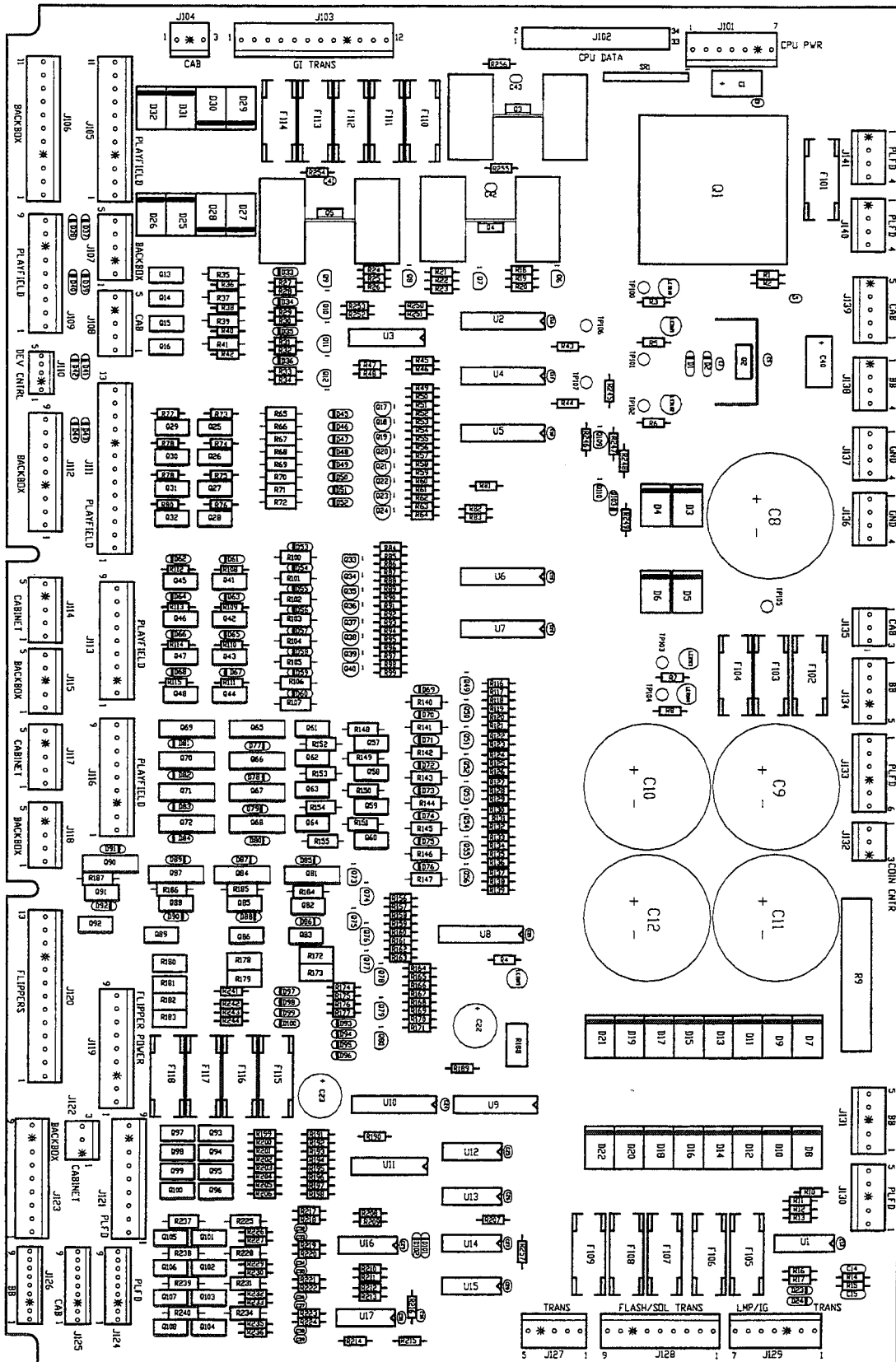

A-21377-50065 WPC '95 CPU PCB Assembly

Part Number	Designator	Description
A-15814	B1	Battery Holder
5048-11033-00	C1, C42	Capacitor, .022m, 50v, 10% Axial
5048-11030-00	C3-C26, C34-C41	Capacitor, 470p, 50v, Axial
5043-09030-00	C27	Capacitor, .047m, 50v ($\pm 20\%$) Axial
5048-13375-00	C28	Capacitor, 100p, 50v (10%) Axial
5048-11028-00	C29, C30, C43, C44	Capacitor, 22p, 50v Axial
5040-14569-00	C31, C77	Capacitor, 100mf, 25v Axial
5048-11031-00	C32	Capacitor, .001m, 50v, 10% Axial
5043-08996-00	C45-C70, C74-C76	Capacitor, 0.1m, 50v ($\pm 20\%$) Axial
5040-13098-00	C73	Capacitor, 4.7 μ F, @35v ($\pm 20\%$)
5645-09025-00	DIPSW1	Switch Dip 8 Pos
5070-09266-00	D1, D25	Diode 1N5817 1.0A.
5070-08919-00	D2-D24, D26, D27	Diode 1N4148 150ma
5700-10176-00	G10A	Socket Dip 28.6
5700-12088-00	G11	Socket Dip 32.6p"
5700-08985-00	U4	Socket I C 40PI N .6
5700-12424-00	U9	socket 84 PI N PL CC
5700-10389-00	U20	Socket I C 18 PIN 3"
5791-10850-00	J201	26H STR Sq. .100
5791-12516-00	J211, J202	34 HDR 2x17 .100
5791-13830-12	J205	12H STR Sq. Pin .100 Solid Tab
5791-13830-09	J206, J207, J209	9H STR Sq. Pin .100 Solid Tab
5791-13830-14	J208	14H STR Sq. Pin .100 Solid Tab
5791-10862-07	J210	7H STR Sq. Pin .156
5791-13830-13	J212	13H STR Sq. Pin .100 Solid Tab
5671-14516-00	LED201, LED202, LED203	LED DSPL RED T-1 3/4
5160-10269-00	Q1	Trans 2N3904 NPN
5019-09669-00	RP1	SIP 1K 9R 10 5%
5010-09358-00	R1, R2, R3, R4, R9, R10, R11, R23, R24, R25, R26, R43, R44, R45, R46, R47, R48, R49, R50, R51, R52, R53, R54, R55, R56, R57, R58, R59, R60, R61, R62, R63, R64, R65, R66, R67, R68, R69, R70, R71, R72, R73, R74, R75, R76, R77, R78, R79, R80, R81, R82, R83, R84, R93, R95, R96, R97, R99, R100, R101, R102, R103, R104, R105, R106, R107, R108, R109, R110, R111, R112, R113, R114, R117	Resistor, 1K Ω , 1/4w, 5%
5010-09416-00	R5, R6, R7, R8, R12, R13, R87, R88, R89	Resistor, 470 Ω , 1/4w, 5%
5010-09034-00	R14, R15, R16, R17, R18, R19, R20, R21, R22, R27, R28, R29, R30, R31, R32, R33, R34, R35, R36, R37, R38, R39, R40, R41, R42, R86, R90, R94, R98	Resistor, 10K Ω , 1/4w, 5%
5010-12104-00	R91	Resistor, 22M, 1/4w, 5%
5010-10989-00	R92	Resistor, 470K Ω , 1/4w, 5%
5010-09187-00	R118, R119, R120, R121, R122, R123, R128, R130	Resistor, 150 Ω , 1/4w, 5%
5010-09534-00	W3, W4, W7, R124, R125	Resistor, 0 Ω , 0w
5010-10258-00	R126	Resistor, 1M, 1/4w, 5%
5010-09040-00	R127	Resistor, 33 Ω , 1/4w, 5%
5281-09867-00	U1, U2	I C 74LS244 OCT BUF
5281-09308-00	U3	I C 74LS245 TRNC
5281-09851-00	U5	I C 74LS14 SMT/TRG
5315-12031-00	U7	I C 74HCT244
5340-12558-00	U8	I C RAM 8K x8 Static Cmos 100ns
5370-12687-00	U10	I C MC 34064 Reset CHP
5281-10182-00	U11, U12, U13, U15	I C 74LS240 L/DRVR
5311-14068-00	U14, U24	I C 74HC574 OCTAL D-Latch
5370-12272-00	U16, U17, U18, U19, U25, U26	I C LM339 Quad Comp
5284-12651-00	U21	I C 4584 Hex Schmitt
5311-14554-00	U23	U I C 74HC237 3 to 8 NON I NV DE
5281-09247-00	U27	I C 74LS02 Quad Nor
5520-12084-00	X1	Crystal 32. 768 KHZ
5520-14761-00	X2	XTL 8MHz Anti-Res Parallel Cut
A-5400-50065-1	G10	PIC16C57 Assembly
A-5343-50065-1	G11	Game ROM Assembly
5880-09022-00	B1	Battery 1.5v, AA Alk.
5400-10320-00	U4	IC MPU 68B09E
5410-12426-00	U9	IC WPC-89 ASIC
5162-12422-00	U20	Trans Uln 2803 Oc-Drl

A-21377-50065 WPC '95 CPU PCB Assembly

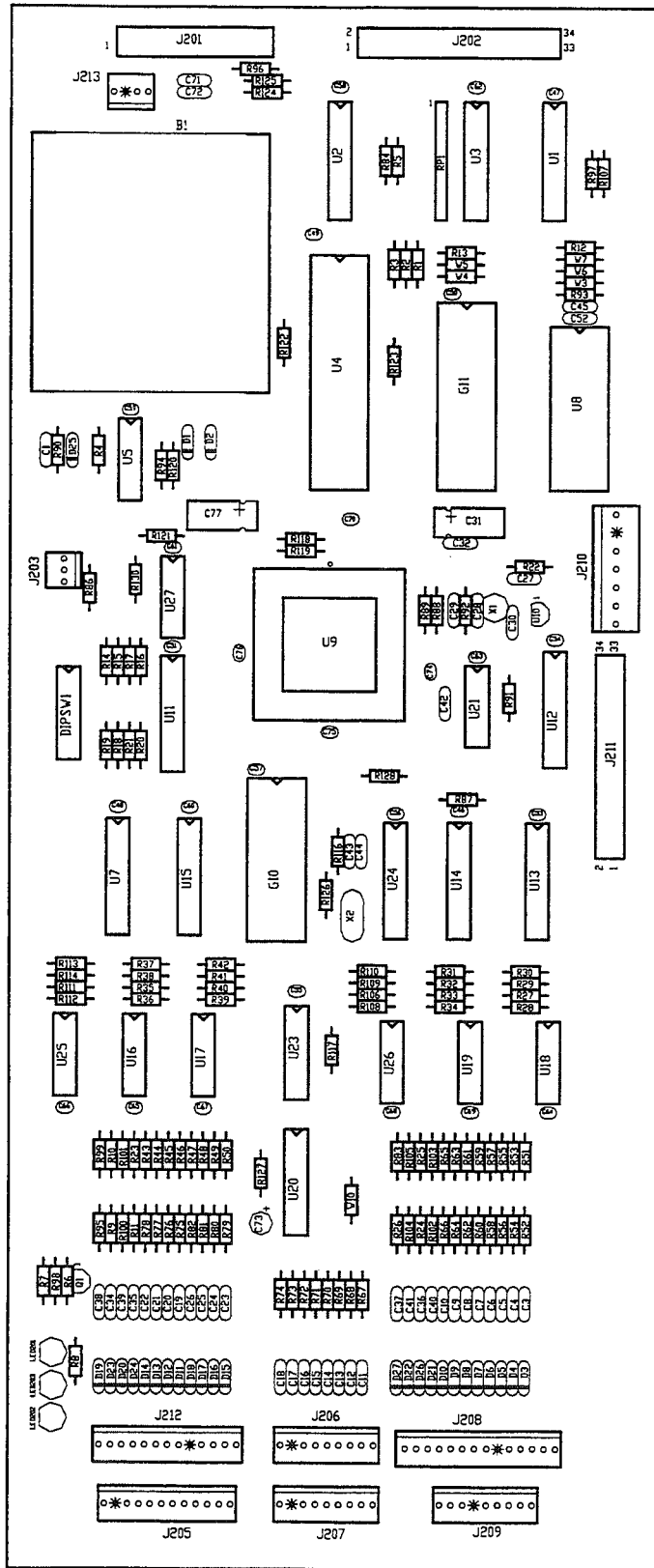

A-18617-1 Trough IR LED PCB Assembly

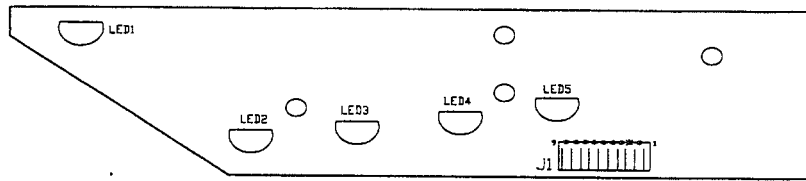

Part Number	Description	Description
5671-12731-00	LED1 - LED	Infra Red Diode
5791-12622-09	J1	Connector, 9-pin Header Sq.

A-18618-1 Trough IR Photo Transistor PCB Assembly

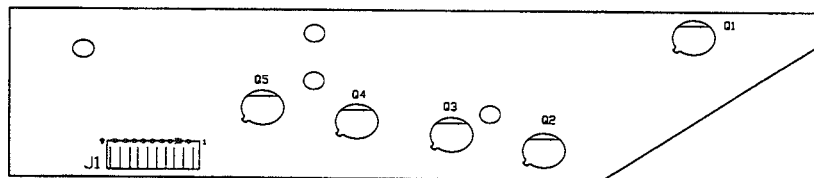

Part Number	Description	Description
5163-14114-00	Q1 -Q5	Infra Red Photo Trans.
5791-12622-09	J1	Connector, 9-pin Header Sq.

A-15542 Motor EMI Assembly

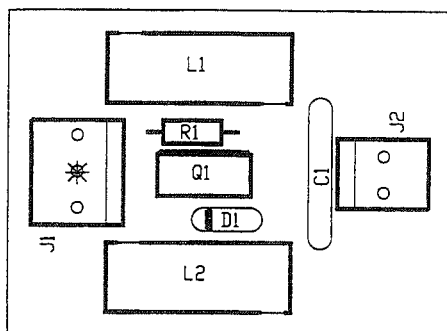

Part Number	Designator	Description
5551-09822-00	L1, L2	Ind. 4.7 μ H, 3A.
5791-12273-03	J1	Connector, 3-Pin Hdr.
5791-12273-02	J2	Connector, 2-Pin Hdr.
5070-09054-00	D1	Diode 1N4004, 1.0A.

A-20580 Coin Interface PCB Assembly

(This board does not contain optional items such as the coin counter and printer interface.)

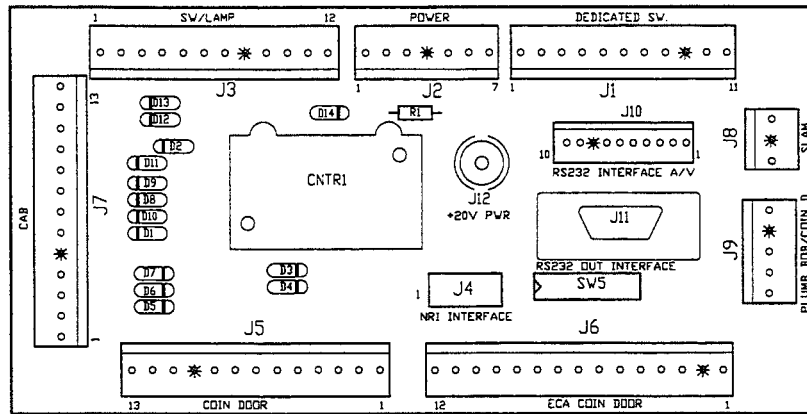

Part Number	Designator	Description
5070-09054-00	D1-D14	Diode 1N4004 1.0A.
5791-10862-11	J1	Connector, 11-pin Header Str. Sq.
5791-10862-07	J2	Connector, 7-pin Header Str. Sq.
5791-10862-12	J3	Connector, 12-pin Header Str. Sq.
5791-11000-10	J4	Connector, 10-pin Header Str. Sq.
5791-10862-13	J5, J7	Connector, 13-pin Header Str. Sq.
5791-10862-15	J6	Connector, 15-pin Header Str. Sq.
5791-10862-03	J8	Connector, 3-pin Header Str. Sq.
5791-10862-05	J9	Connector, 5-pin Header Str. Sq.
5791-12462-10	J10	Connector, 10-pin Header Str. Sq.
5010-13517-00	R1	Resistor, 15Ω, 1/4w, 5%
5645-09025-00	SW5	Switch DIP 8 Pos.

A-17316 Flipper Opto PCB Assembly

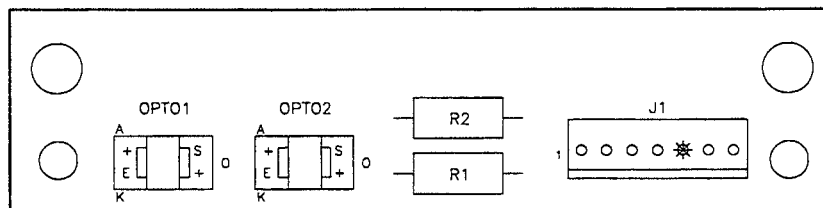

Part Number	Designator	Description
A-20207.1	-	Flipper Opto Switch PCB
5010-09061-00	R1, R2	Resistor, 680Ω, 1/2w, 5%
5490-14575-00	OPTO1, OPTO2	IC Opto Integ Schmitt 10mA.
5791-13830-07	J1	Connector, 7-pin Header Solid Sq.
03-9001.1	-	Interrupter Flip-Opto
01-14348	-	Spring Flipper Switch

A-22149-1 Auto Adjust Eddy Sensor PCB

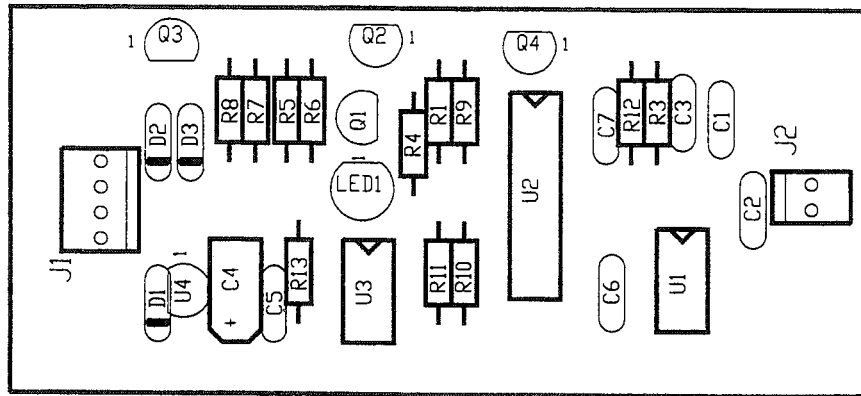

Part Number	Designator	Description
5048-12036-00	C3	Capacitor, .22m, 50v, Axial
5010-09999-00	R5, R6, R8, R10	Resistor, 2K Ω , 1/4w, 5%
5010-08992-00	R4, R12	Resistor, 560 Ω , 1/4w, 5%
5010-09034-00	R7, R11	Resistor, 10K Ω , 1/4w, 5%
5010-09807-00	R3	Resistor, 120 Ω , 1/4w, 5%
5010-09534-00	R1	Resistor, 0 Ω
5010-09160-00	R13	Resistor, 220 Ω , 1/4w, 5%
5041-09031-00	C4	Capacitor, 1M, 25v, \pm 20% Axial
5048-13609-00	C1, C2	Capacitor, 390pf, 50v, 5% Axial
5043-08996-00	C5-C7	Capacitor, 0.1m, 50v, \pm 20% Axial
5070-08919-00	D1-D3	Diode 1N4148 150ma
5160-10269-00	Q1, Q3, Q4	Trans 2N3904 NPN
5190-10270-00	Q2	Trans 2N3906
5250-13302-00	U4	Reg. 78105t 5v
5370-13452-00	U1	IC TDA0161 Prox Sensor
04-11001	U3	IC Auto Adjust Eddy Controller
5432-15411-00	U2	IC Dual E2POT X9221W
5671-13732-00	LED1	Led Dspl Red
5791-13830-02	J2	Connector, 2-pin Header Str Sq.
5791-13830-04	J1	Connector, 4-pin Header Str Sq.
5700-09329-00	U3	Socket Dip 8 pin

A-21402 Defender Switch Board Assembly

(See page 2-13 for PCB diagram)

Part Number	Designator	Description
5043-08996-00	C1	Capacitor, .1m, 50v, \pm 20% Axial
5070-09054-00	D1-D10	Diode 1N4004 1.0A.
5791-12622-09	J1	Connector, 9-pin Header
5160-10269-00	Q1-Q5	Trans. 2N3904 NPN
5010-09061-00	R1, R4, R7, R10, R13	Resistor, 680 Ω , 1/2w, 5%
5010-09358-00	R2, R5, R8, R11, R14	Resistor, 1K Ω , 1/4w, 5%
5010-08998-00	R3, R6, R9, R12, R15	Resistor, 2.2K Ω , 1/4w, 5%
5490-14575-00	U1-U5	IC Opto Inter w/Switch 10mA.

A-20246 10-Opto PCB Assembly w/Bracket

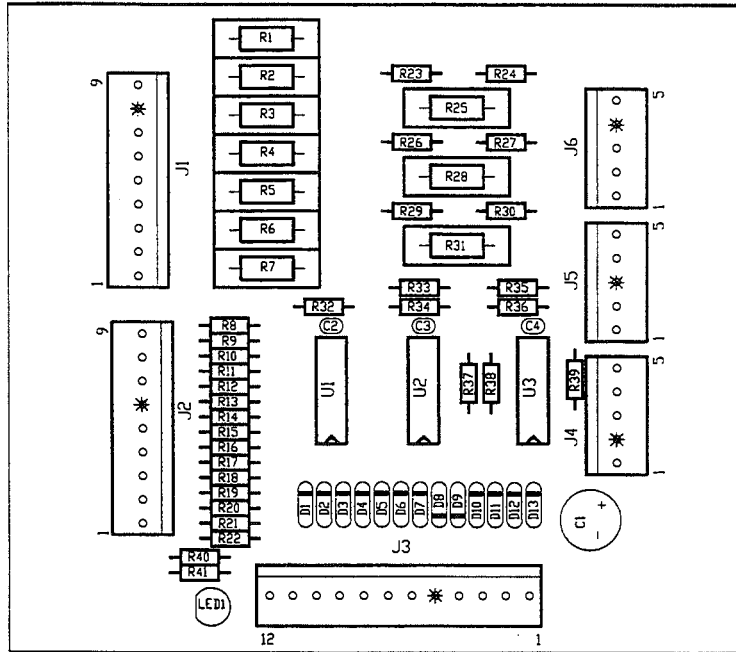

Part Number	Designator	Description
A-18159.1	-	10-opto PCB Assembly
5040-10974-00	C1	Capacitor, 100M, 35v Radial
5043-08996-00	C2-C4	Capacitor, 0.1M, 50v ±20% Ax.
5070-09054-00	D1-D13	Diode 1N4004, 1.0A.
5791-10862-09	J1, J2	Connector, 9-pin Header
5791-10862-12	J3	Connector, 12-pin Header
5791-10862-05	J4-J6	Connector, 5-pin Header
5671-14516-00	LED1	LED Dspl Red T-1 3/4
5010-12928-00	R1-R7, R28, R31, R50	Resistor, 270Ω, 2w, 5%
5010-09999-00	R8-R24, R26, R27, R29, R30	Resistor, 2KΩ, 1/4w, 5%
5010-09162-00	R32, R35, R39-R41	Resistor, 100KΩ, 1/4w, 5%
5010-08774-00	R34, R36-R38	Resistor, 22KΩ, 1/4w, 5%
5370-12272-00	U1-U3	IC LM339 Quad Comp
5010-08776-00	R33	Resistor, 68KΩ, 1/4w, 5%
01-10756	-	PCB Mounting Bracket
07-6688-18N	-	Rivet: 1/8 x 3/16"

A-21402 Defender Switch Board Assembly (see page 2-12 for parts listing)

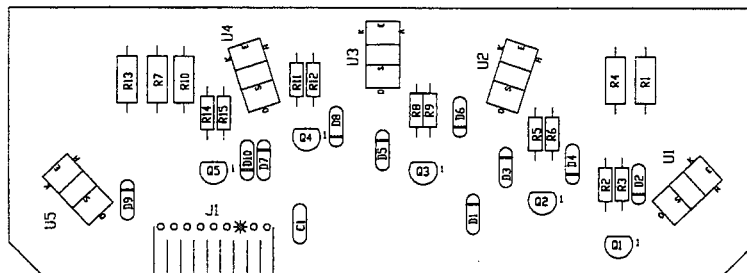

A-16120 DC Motor Control Assembly (4 Way)

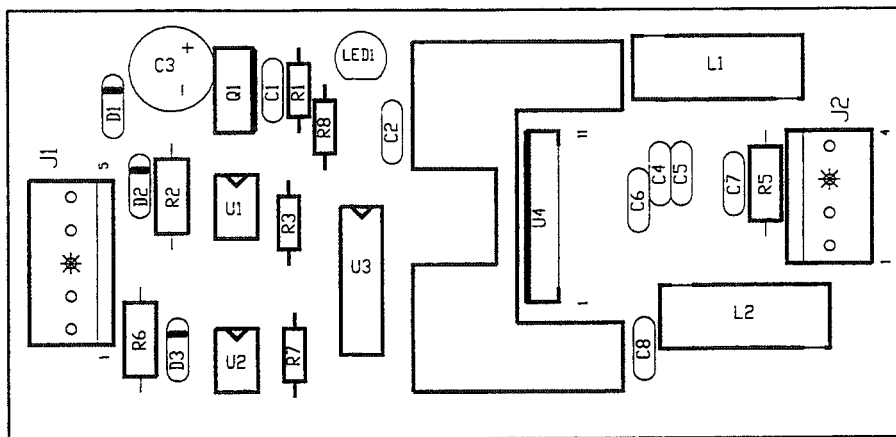

Part Number	Designator	Description
5791-12273-04	J2	Connector 4-H STR Sq. Lck. .156
5791-12273-05	J1	Connector 5H STR Sq. Lck. .156
5671-13732-00	LED1	Display RED LED
5070-09054-00	D1-D3	Diode 1N4004 1A.
5551-09822-00	L1, L2	Ind. 4.7µH, 3A.
5010-09061-00	R2, R6	Resistor, 680µ, 1/2w, 5%
5010-10255-00	R5	Resistor, 10Ω, 1/2w, 5%
5010-08997-00	R3, R7, R8	Resistor, 2.7KΩ, 1/4w, 5%
5010-09085-00	R1	Resistor, 1.5KΩ, 1/4w, 5%
5040-10974-00	C3	Capacitor, 100µF, 35V. Rad.
5281-09500-00	U3	IC 74LS32 Quad OR
5370-13342-00	U4	IC 3A. DMOS Bridge Driver
5490-10892-00	U1, U2	IC Opto Isolator 4N25
5250-09157-00	Q1	Reg. 7805 1A 5V
5043-08980-00	C2, C4, C6-C8	Capacitor, 0.01µF, 50v, +80-20%
5043-12807-00	C1	Capacitor, 1µF, 50v, +80-20%
5043-08996-00	C5	Capacitor, 0.1µF, 50v, +80-20%

A-17796-1 Ball Gate Actuator Assembly

Item	Part Number	Description
1	01-12348	Ball Gate Coil Bracket
2	A-14406	Coil Assembly
3	A-11146	Armature Assembly
4	A-6892	Frame & Eyelet Assy.
5	10-120	Spring
6	4701-00003-00	Lockwasher #18 Split
7	4700-00089-00	Flat Washer: 11/64 x 7/16 x 16ga.
8	4008-01021-07	Mach. Screw, 8-32 x 7/16"
9	10-194	Extension Spring
10	H-19523-1	Cable

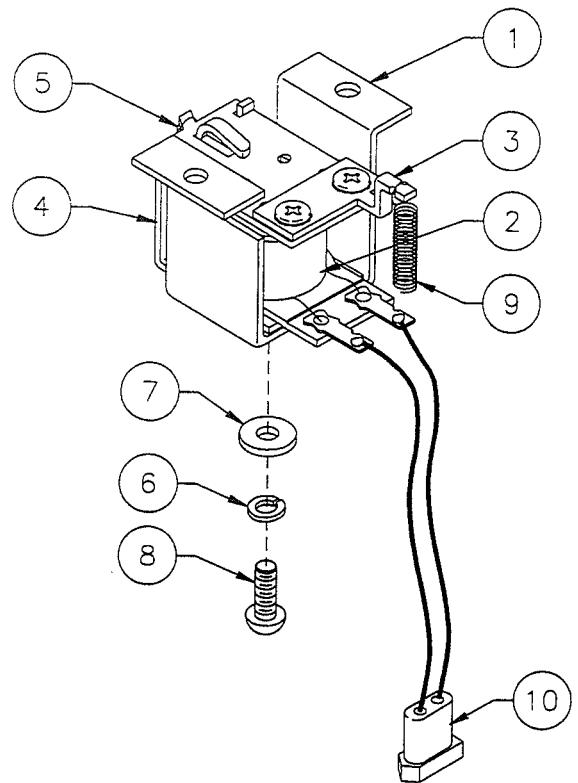

A-22449 Eject Assembly

Item	Part Number	Description
1	04-10702.2-1	NBA Eject Bracket
2	AE-30-2000	Coil Assembly
3	5647-12693-66	Sub-Mini Micro Switch
4	10-135	Plunger Spring
5	04-10322-2	Coil Bracket 8-32 Stud
6	23-6420	Rubber Grommet
7	A-15371	Plunger Assembly
8	03-7067-5	Coil Tubing
9	4002-01105-06	Mach. Screw, 2-56 x 3/8"
10	4408-01119-00	Nut 8-32 ESNA
11	H-16437	Mini Switch Cable
12	5070-09054-00	Diode

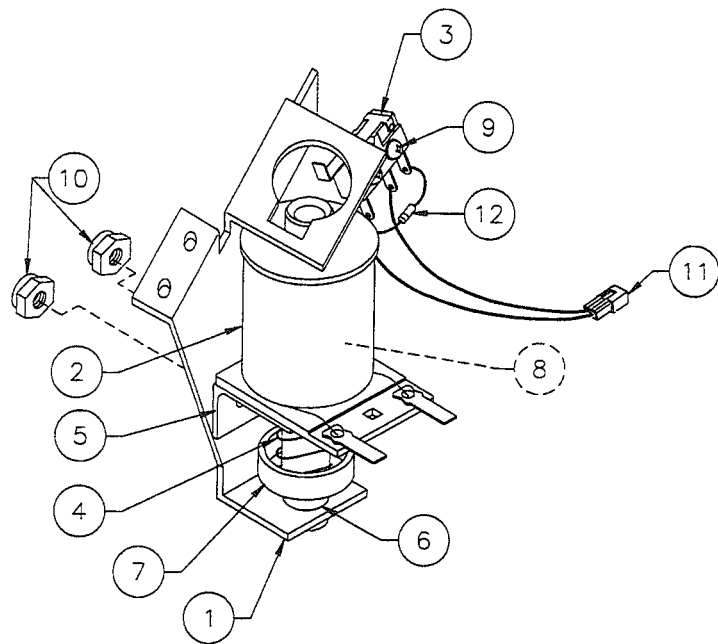

A-15849-L-2 Flipper Assembly

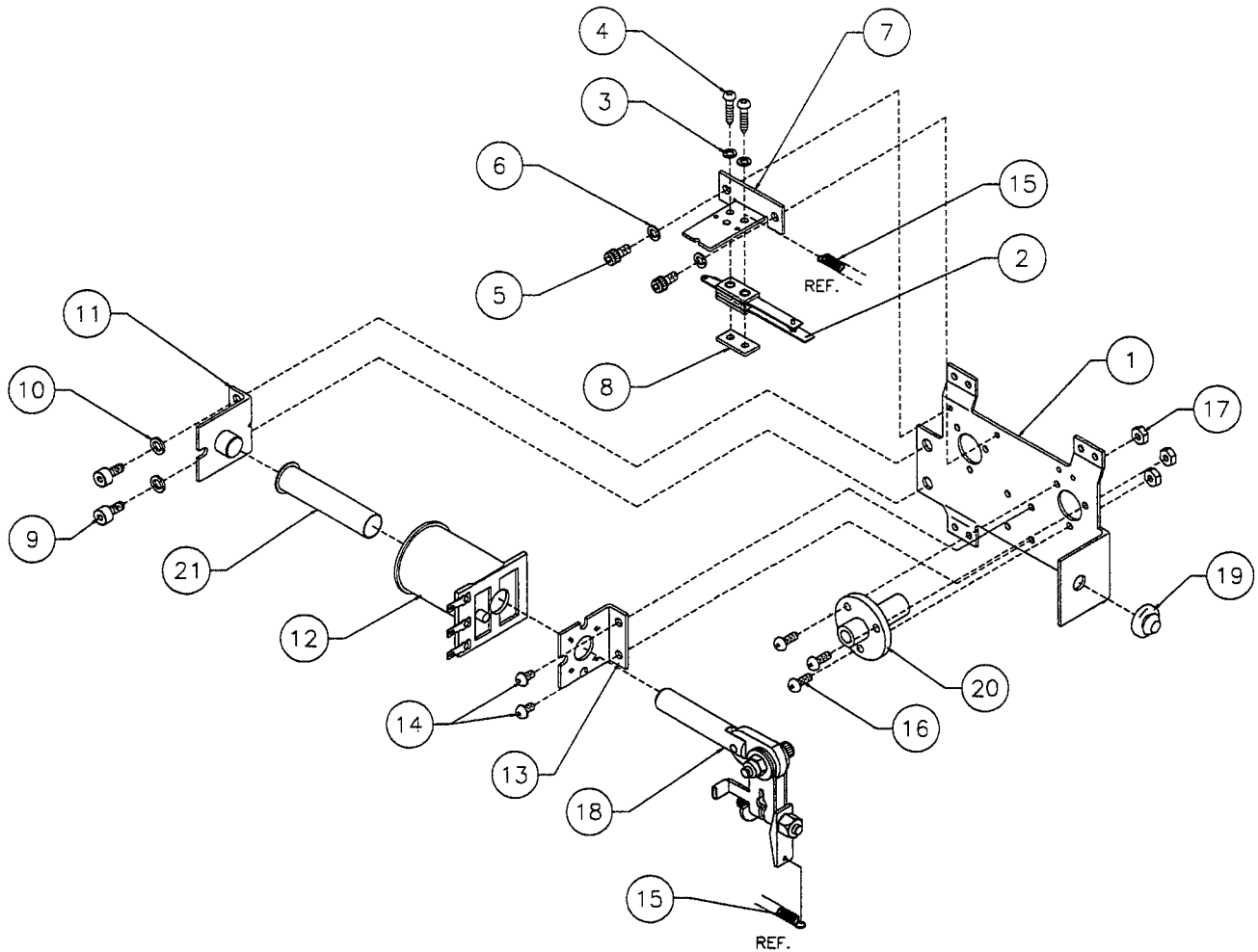

Item	Part Number	Description	Item	Part Number	Description
1	B-13104-L	Flipper Base Assembly, Left	*18	A-15848-L	Crank Link Assembly, Left
2	SW-1A-194	Switch Assembly	a)	A-17050-L	Flipper Crank Assembly, Left
3	4701-00002-00	Lock Washer #6 Split	b)	A-15847	Flipper Link Assembly
4	4105-01019-10	Sh. Metal Screw, #5 x 5/8"	c)	02-4676	Link Spacer Bushing
5	4008-01079-05	Mach. Screw, 8-32 x 5/16"	d)	4010-01086-14	Cap Screw, 10-32 x 7/8"
6	4701-00003-00	Lock Washer #8 Split	e)	4700-00023-00	Flat Washer, 5/8 x 13/64 x 16ga.
7	01-9375	Switch Mounting Bracket	f)	4701-00004-00	Lock Washer #10 Split
8	20-6516	Speednut, Tinnerman	g)	4410-01132-00	Nut 10-32 ESN
9	4010-01066-06	Cap Screw, 10-32 x 3/8"	19	23-6577	Bumper Plug, 5/8"
10	4701-00004-00	Lock Washer #10 Split	20	03-7568	Flipper Bushing
11	A-12390	Flipper Stop Assembly	21	03-7066-5	Coil Tubing
12	FL-11629	Flipper Coil			
13	01-7695-1	Solenoid Bracket			
14	4006-01017-04	Mach. Screw, 6-32 x 1/4"			
15	10-364	Spring			
16	4006-01005-06	Mach. Screw, 6-32 x 3/8"			
17	4406-01117-00	Nut 6-32 Hex.			

Associated Parts: (Not Shown)

23-6695	Flipper Ring
20-10110-5	Flipper Bat w/Shaft

* See page 2-17 for assembly detail drawing.

A-22603-R Flipper Assembly

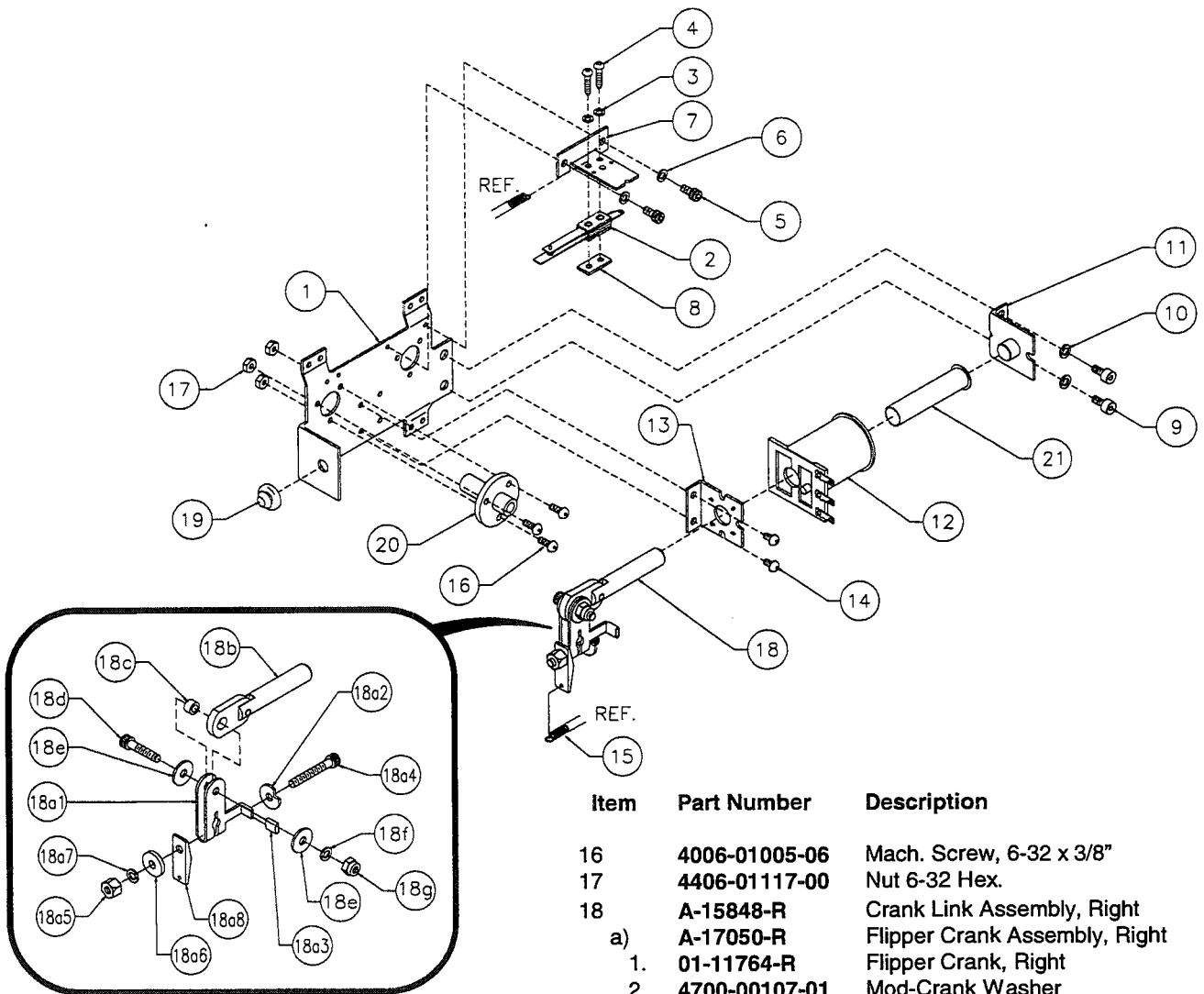

Item	Part Number	Description
1	04-12342	Flipper Base Assembly-Mod., R.
2	SW-1A-194	Switch Assembly
3	4701-00002-00	Lock Washer #6 Split
4	4105-01019-10	Sh. Metal Screw, #5 x 5/8"
5	4008-01079-05	Mach. Screw, 8-32 x 5/16"
6	4701-00003-00	Lock Washer #8 Split
7	01-9375	Switch Mounting Bracket
8	20-6516	Speednut, Tinnerman
9	4010-01066-06	Cap Screw, 10-32 x 3/8"
10	4701-00004-00	Lock Washer #10 Split
11	A-12390	Flipper Stop Assembly
12	FL-11629	Flipper Coil
13	01-7695-1	Solenoid Bracket
14	4006-01017-04	Mach. Screw, 6-32 x 1/4"
15	10-364	Spring

Item	Part Number	Description
16	4006-01005-06	Mach. Screw, 6-32 x 3/8"
17	4406-01117-00	Nut 6-32 Hex.
18	A-15848-R	Crank Link Assembly, Right
a)	A-17050-R	Flipper Crank Assembly, Right
1.	01-11764-R	Flipper Crank, Right
2.	4700-00107-01	Mod-Crank Washer
3.	RM-23-06	H.S. Tubing 1/4"
4.	4010-01066-20	Mach. Screw, 10-32 x 1-1/4"
5.	4410-01127-00	Nut, 10-32 Hex.
6.	4700-00107-00	FW: 13/64 x 5/8 x 12ga.
7.	4701-00004-00	Lockwasher #10 Split
8.	01-9376	Spring Retainer Bracket
b)	A-15847	Flipper Link Assembly
c)	02-4676	Link Spacer Bushing
d)	4010-01086-14	Cap Screw, 10-32 x 7/8"
e)	4700-00023-00	Flat Washer, 5/8 x 13/64 x 16ga.
f)	4701-00004-00	Lock Washer #10 Split
g)	4410-01132-00	Nut 10-32 ESN
19	23-6577	Bumper Plug, 5/8"
20	03-7568	Flipper Bushing
21	03-7066-5	Coil Tubing

Associated Parts: (Not Shown)

23-6695	Flipper Ring
20-10110-5	Flipper Bat w/Shaft

Flipper Notes...

1. Each Flipper Assembly is mounted beneath the playfield, in conjunction with the Plastic Flipper & Shaft, and Flipper Rubber on the upper side of the playfield.
2. With the flipper, in the non-activated position, the E.O.S. Switch contacts must have a gap of .062 (± 0.015) inch. When flipper is activated switch must close.
3. Any adjustment of the E.O.S. switch must be made at a minimum distance of 0.25 inch from the switch body.
4. Longer blade of E.O.S. switch must be made straight. Gap adjustment is done by adjusting shorter blade.
5. All moving elements of the assembly must operate freely without any evidence of binding.
6. Apply Loctite™ 245 when reattaching screws to the Flipper Stop Assembly, the Solenoid Bracket, and the Flipper Bushing.

A-17811 Kicker Arm (Slingshot) Assembly

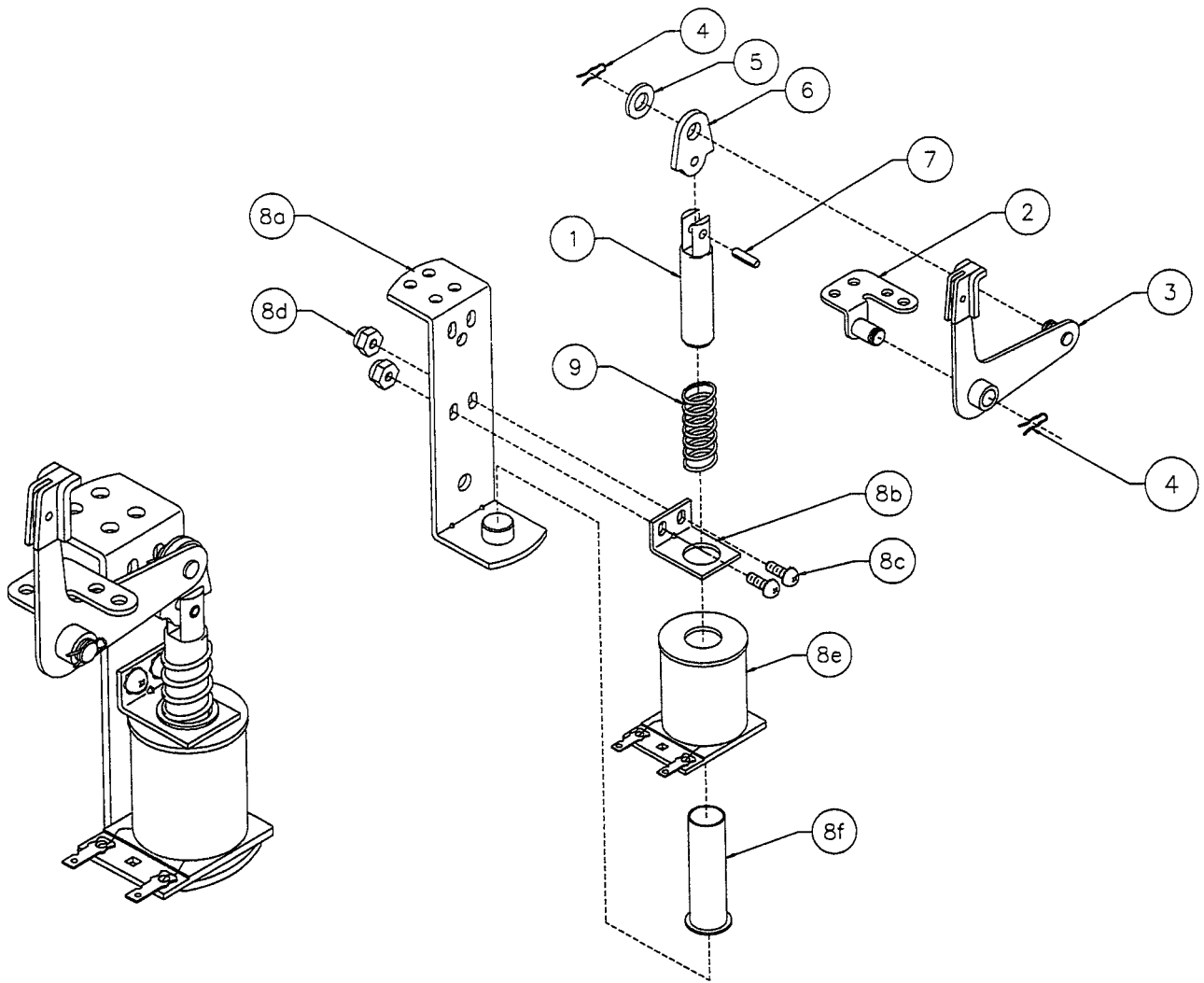

Associated Parts for Right & Left Kickers:

Item	Part Number	Description	Item	Part Number	Description
1	02-2364	Coil Plunger	8	A-22206-2	Coil & Bracket Assembly, R.
2	A-17810	Mounting Bracket Assy.		A-22207-2	Coil & Bracket Assembly, L.
3	A-12664	Kicker Crank Assembly	a)	A-17808	Bracket & Stop Assembly
4	12-6227	Hairpin Clip	b)	01-8-508-S	Coil Retaining Bracket
5	4700-00030-00	FW, 17/64 x 1/2 x 15ga.	c)	4006-01017-06	Mach. Screw, 6-32 x 3/8"
6	03-8085	Armature Link	d)	4406-01119-00	Nut, 6-32 ESN
7	20-8716-5	Roll Pin, 1/8 x 7/16"	e)	AE-26-1200	Coil Assembly
			f)	03-7066	Coil Tubing
			9	10-128	Spring

A-19963 Ball Trough Assembly Complete

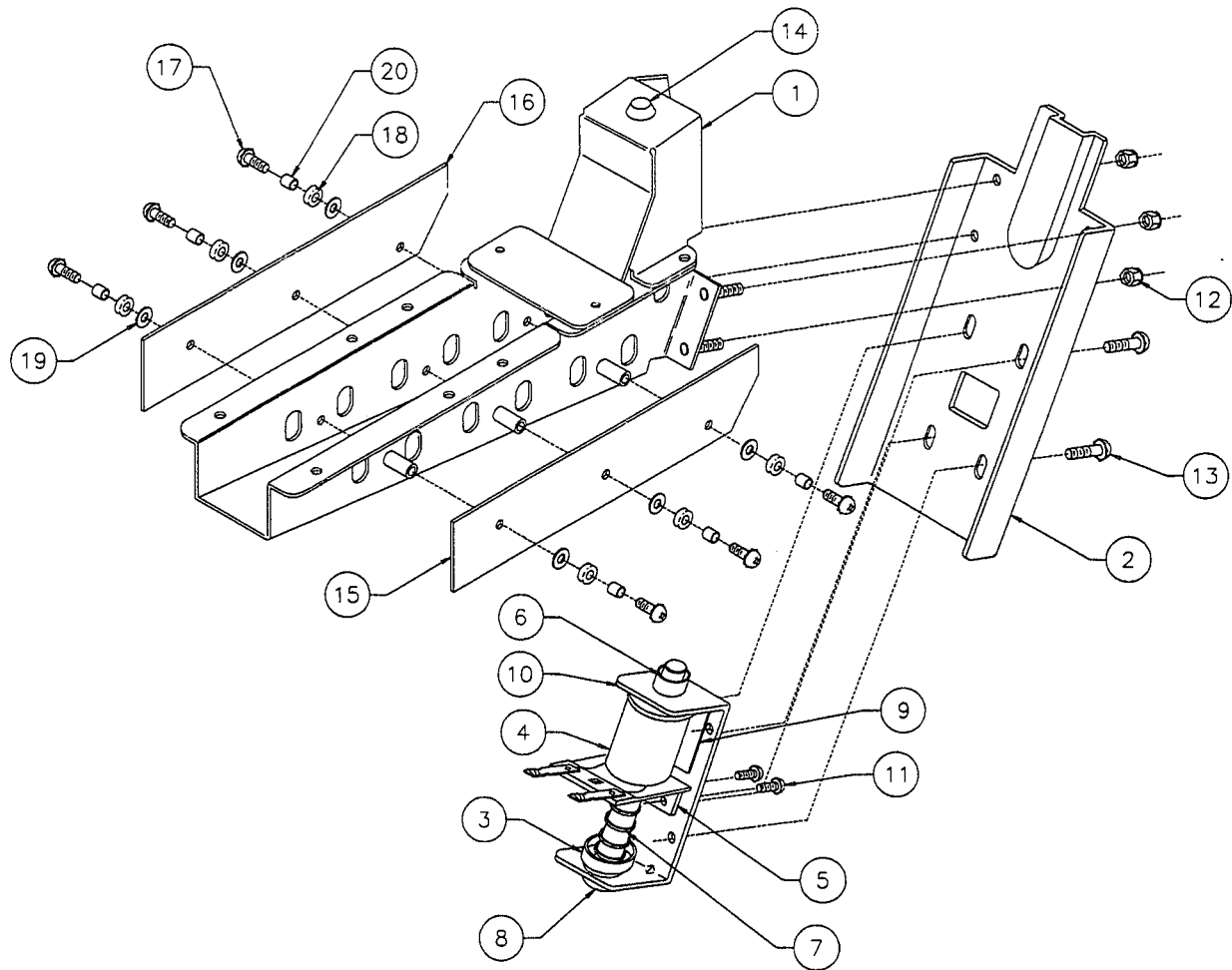

Item	Part Number	Description	Item	Part Number	Description
1	A-16809-2	Ball Trough Welded Assy.	11	4008-01017-05	Mach. Screw, 8-32 x 5/16"
2	01-11587	Ball Trough Front	12	4408-01119-00	Nut 8-32 ESN
3	A-6306-2	Bell Armature Assembly	13	4008-01017-06	Mach. Screw, 8-32 x 3/8"
4	AE-26-1500	Coil Assembly	14	23-6702	Bumper Plug
5	01-8-508-T	Solenoid Assembly	15	A-18617-1	Trough IRED LED PCB Assembly
6	03-7067-5	Coil Tubing	16	A-18618-1	Trough IRED Transistor PCB Assy.
7	10-135	Spring	17	4006-01003-10	Mach. Screw, 6-32 x 5/8" SEMS
8	23-6420	Rubber Grommet	18	23-6626	Rubber Grommet
9	03-8523	Insulator	19	4700-00004-00	Flat Washer, 9/64 x 7/16 x 21ga.
10	01-11586	Coil Mounting Bracket	20	02-4975	Bushing

A-22205-2 Jet Coil & Bracket Assembly

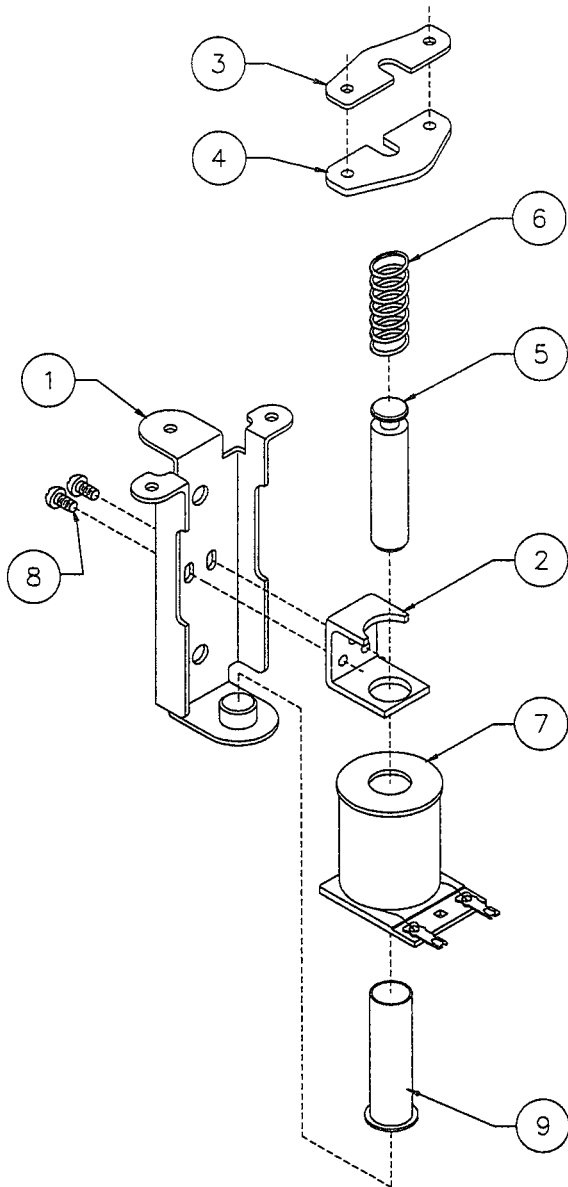

Item	Part Number	Description
1	04-10888	Bracket & Stop Assembly
2	01-1747	Coil Retaining Bracket
3	01-5492	Armature Link, Steel
4	01-5493	Armature Link, Bakelite
5	02-3406-1	Coil Plunger
6	10-326	Armature Spring
7	AE-26-1200	Coil Assembly
8	4006-01017-04	Mach. Screw, 6-32 x 1/4"
9	03-7066	Coil Tubing

Associated Parts: (Not Shown)

10	B-12030-2	Leaf Switch Assembly
a)	A-16443	Switch & Diode Assembly
b)	01-1168	Switch Mounting Bracket
c)	01-3670	Switch Plate
d)	03-7395	Switch Actuator
e)	4005-01003-12	Mach. Screw, 5-40 x 3/4"
f)	4405-01117-00	Nut 5-40 Hex.

B-9414-5 Jet Bumper Assemblies

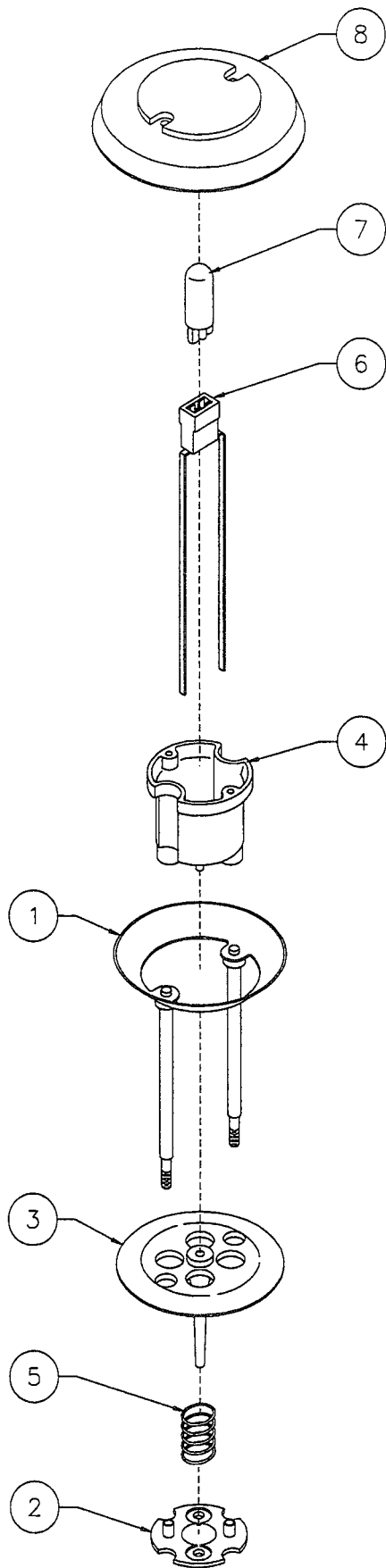

Item	Part Number	Description
1	A-4754	Bumper Ring Assembly
2	03-6009-A5	Bumper Base, White
3	03-6035-15	Bumper Wafer, Orange
4	03-7443-5	Bumper Body, White
5	10-7	Spring
6	24-8776	Socket-Wedge Base
7	24-8768	Bulb #555(6.5v., 0.25A.)

Associated Parts:

8	03-8254-12	Jet Bumper Cap (3)
---	------------	--------------------

A-22429-1 Auto Fire Assembly

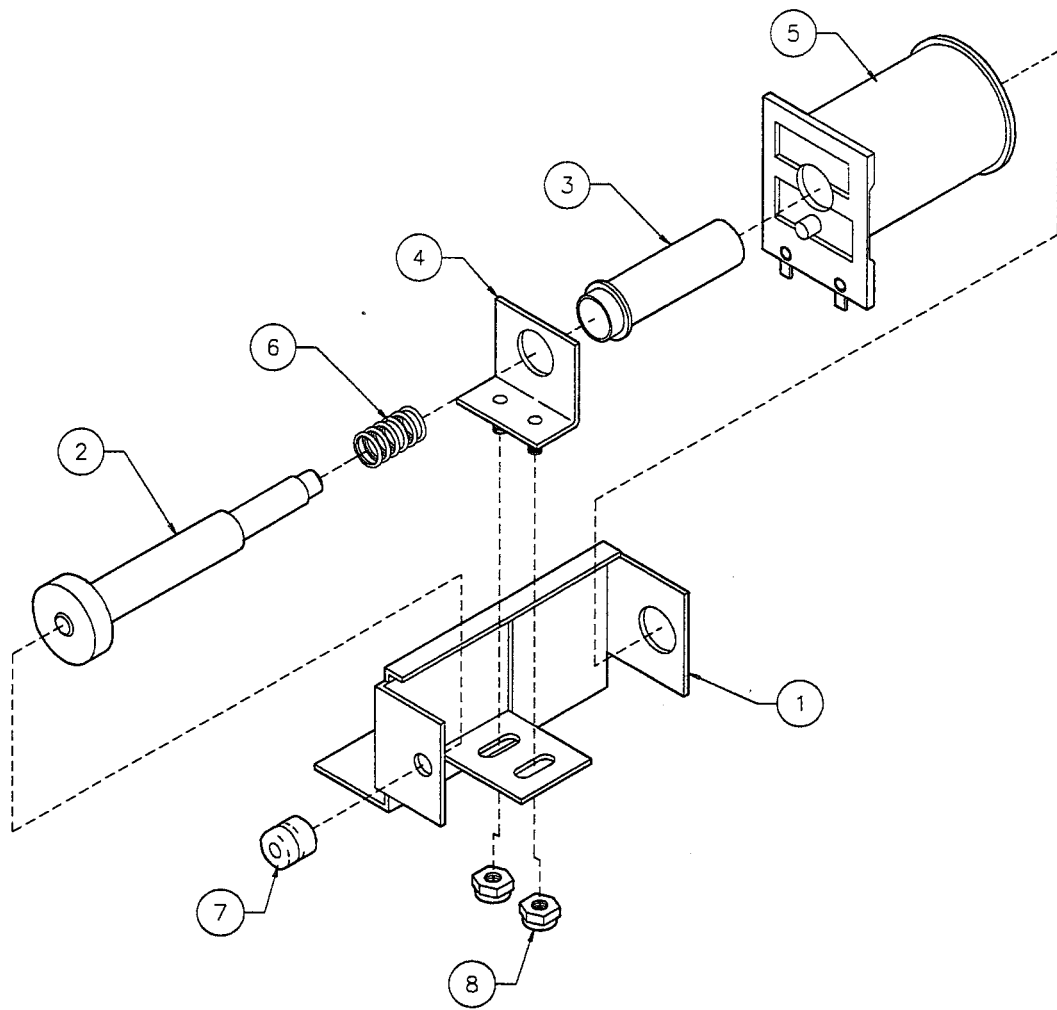

Item	Part Number	Description
1	01-14618.1	Auto Fire Bracket
2	A-6306-2	Plunger
3	03-7067	Coil Tubing
4	04-10322-2	Coil Bracket
5	AE-24-900	Coil Sub-Assembly
6	10-135	Spring
7	23-6420	Rubber Grommet
8	4408-01119-00	Nut, 8-32 ESN

A-22293 Up Down Post Assembly

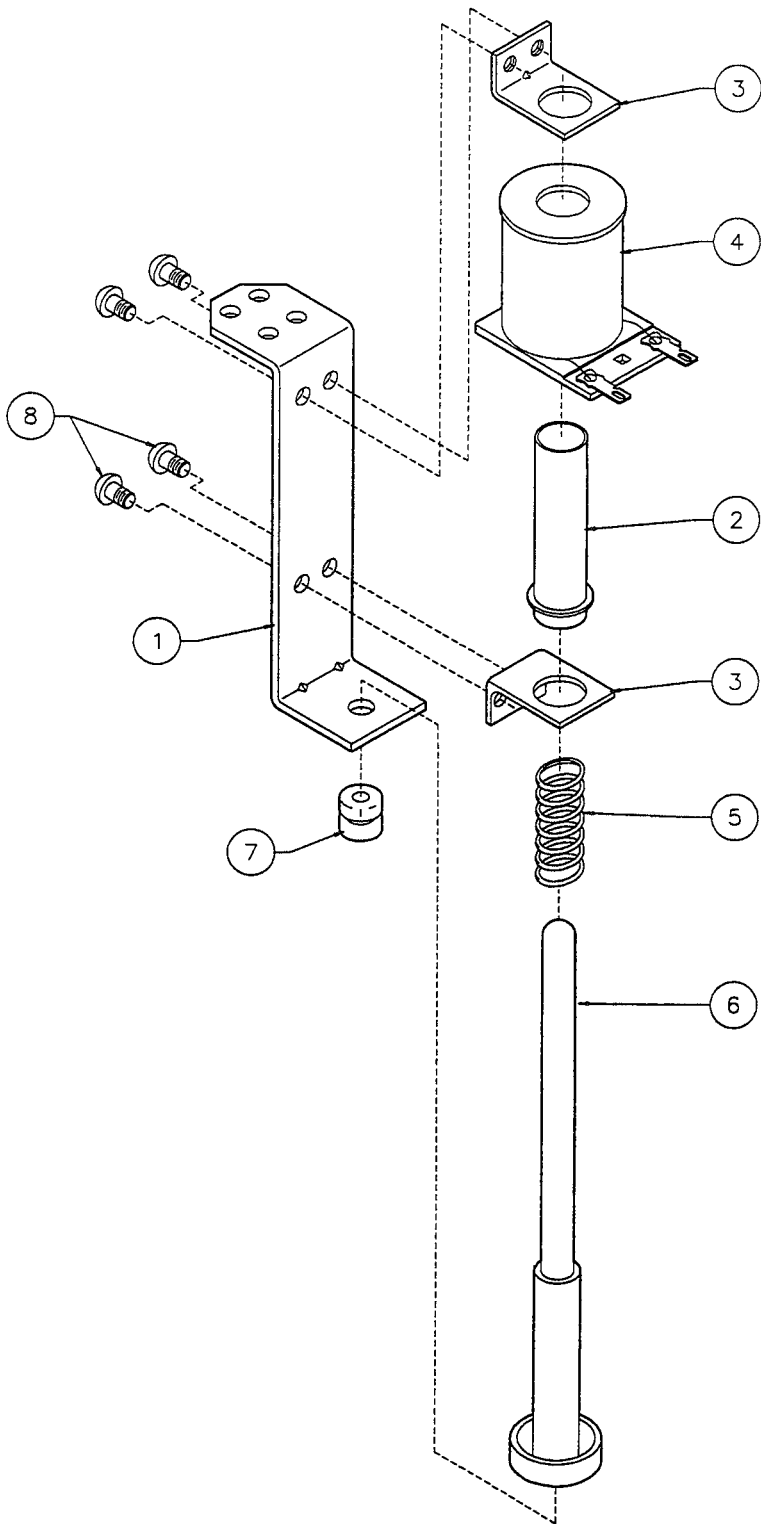

Item	Part Number	Description
1	01-12441	Diverter Post Bracket
2	03-7067-5	Coil Tubing
3	01-8-508-T	Coil Retainer Bracket
4	AE-27-1200	Coil Assembly
5	10-135	Spring
6	04-11212	Armature Assembly
7	23-6420	Rubber Grommet
8	4008-01017-04	Mach. Screw: 8-32 x 1/4"

A-22266 Popper Assembly

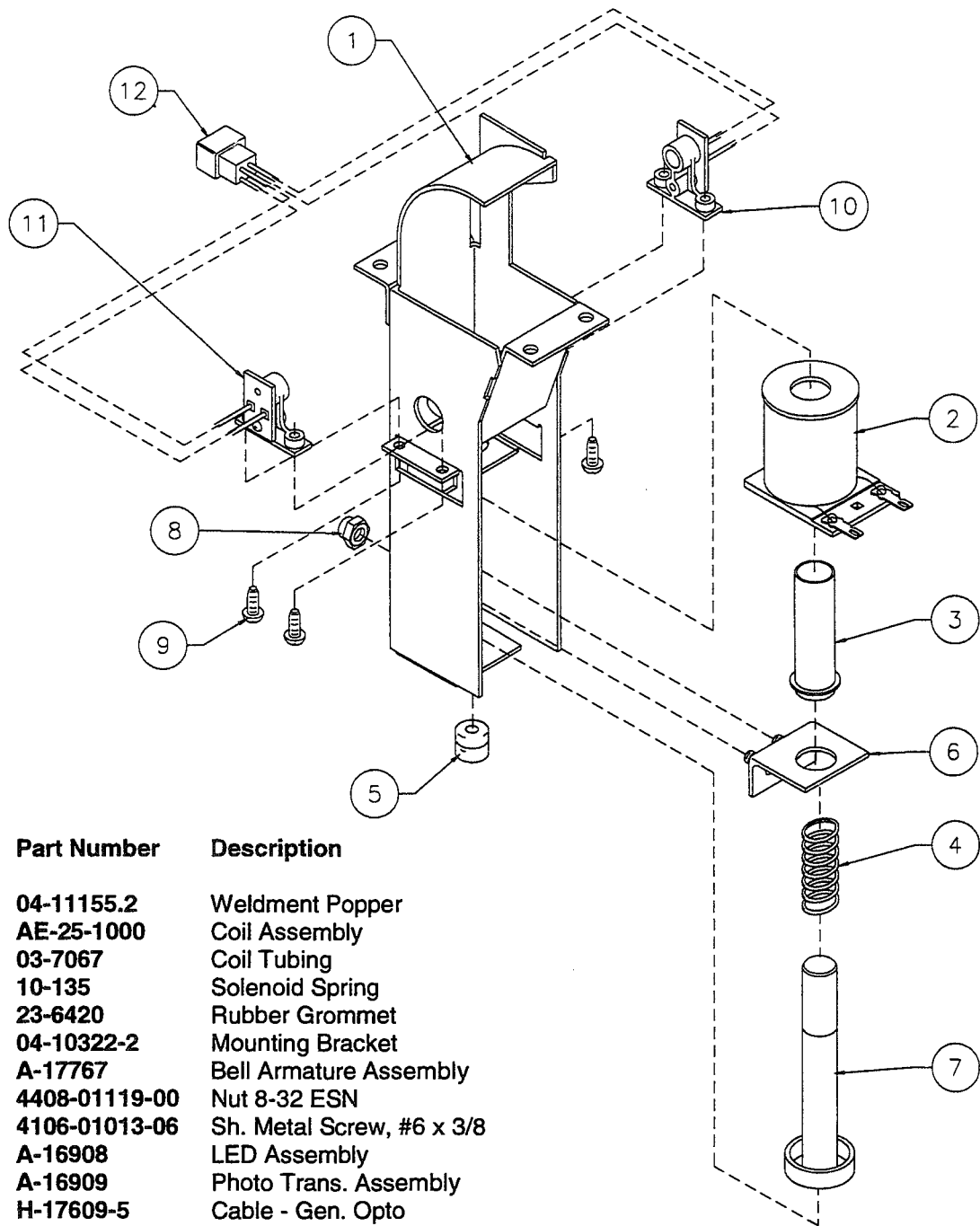

Item	Part Number	Description
1	04-11155.2	Weldment Popper
2	AE-25-1000	Coil Assembly
3	03-7067	Coil Tubing
4	10-135	Solenoid Spring
5	23-6420	Rubber Grommet
6	04-10322-2	Mounting Bracket
7	A-17767	Bell Armature Assembly
8	4408-01119-00	Nut 8-32 ESN
9	4106-01013-06	Sh. Metal Screw, #6 x 3/8
10	A-16908	LED Assembly
11	A-16909	Photo Trans. Assembly
12	H-17609-5	Cable - Gen. Opto

A-22425 Bride Mechanism Assembly

Item	Part Number	Description
1	01-14985	Bride Mech. Bracket
2	03-7067	Coil Tubing
3	01-8-508-T	Coil retainer Bracket
4	AE-26-1500	Coil Assembly
5	10-135	Spring
6	01-14172	Coil Stop Bracket
7	23-6420	Rubber Grommet
8	4008-01017-04	Mach. Screw: 8-32 x 1/4"
9	02-5453.1	Shaft Bride
10	04-11194	Bride Armature Assembly
11	4701-00003-00	Lockwasher #8 Split

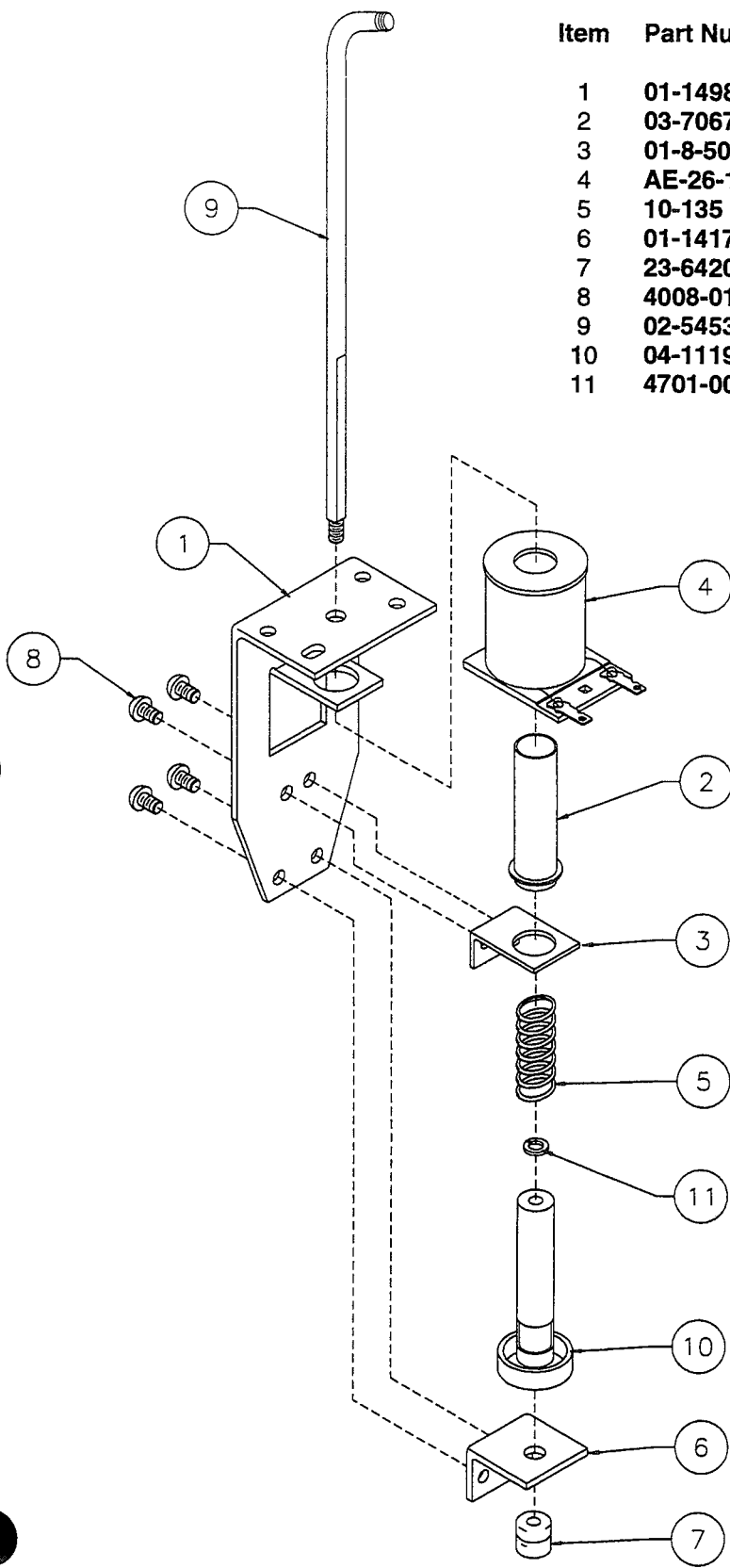

A-22297 Monster Table Assembly

Item	Part Number	Description	Item	Part Number	Description
1	A-22298	Monster Sub-Assy.	2	04-11174.2	Table
a)	A-22299	Monster Arm Sub-Assy.	3	01-14849	Table Support Brkt., Left
1.	04-11176	Arm Pivot Support Brkt.	4	01-14850	Table Support Brkt., Right
2.	04-11175	Arm Pivot Actuator	5	02-5446	Table Pivot Shaft
3.	01-14956	Arm Washer	6	02-5447	Monster Pivot Shaft
4.	02-5448	Arm Pivot Shaft	7	03-8365-18	Post # 8, Trans. Violet
5.	10-539	Arm Pivot Spring	8	20-8790	Nyliner Bearing
6.	31-3104	Monster Arm Left	9	20-8712-12	E-Ring, 1/8" Shaft
7.	31-3105	Monster Arm Right	10	4008-01113-40	Mach. Screw: 8-32 x 2-1/2"
8.	4008-01083-04	Set Screw< 8-32 x 1/4"	11	4008-01113-04	Mach. Screw: 8-32 x 1/4"
9.	4004-01073-04B	Cap Screw, 4-40 x 1/4"	12	5647-12693-69	Sub Mini Micro Switch
10.	20-8712-18	E-Ring, 3/16" Shaft	13	4002-01105-06	Mach. Screw: 2-56 x 3/8"
b)	31-3103	Monster Figurine	14	5070-09054-00	Diode 1N4004, 1.0A.
c)	4004-01073-04B	Cap Screw: 4-40 x 1/4"	15	H-18214-1	Cable
			16	03-9454	Ty-Wrap

A-22297 Monster Table Assembly

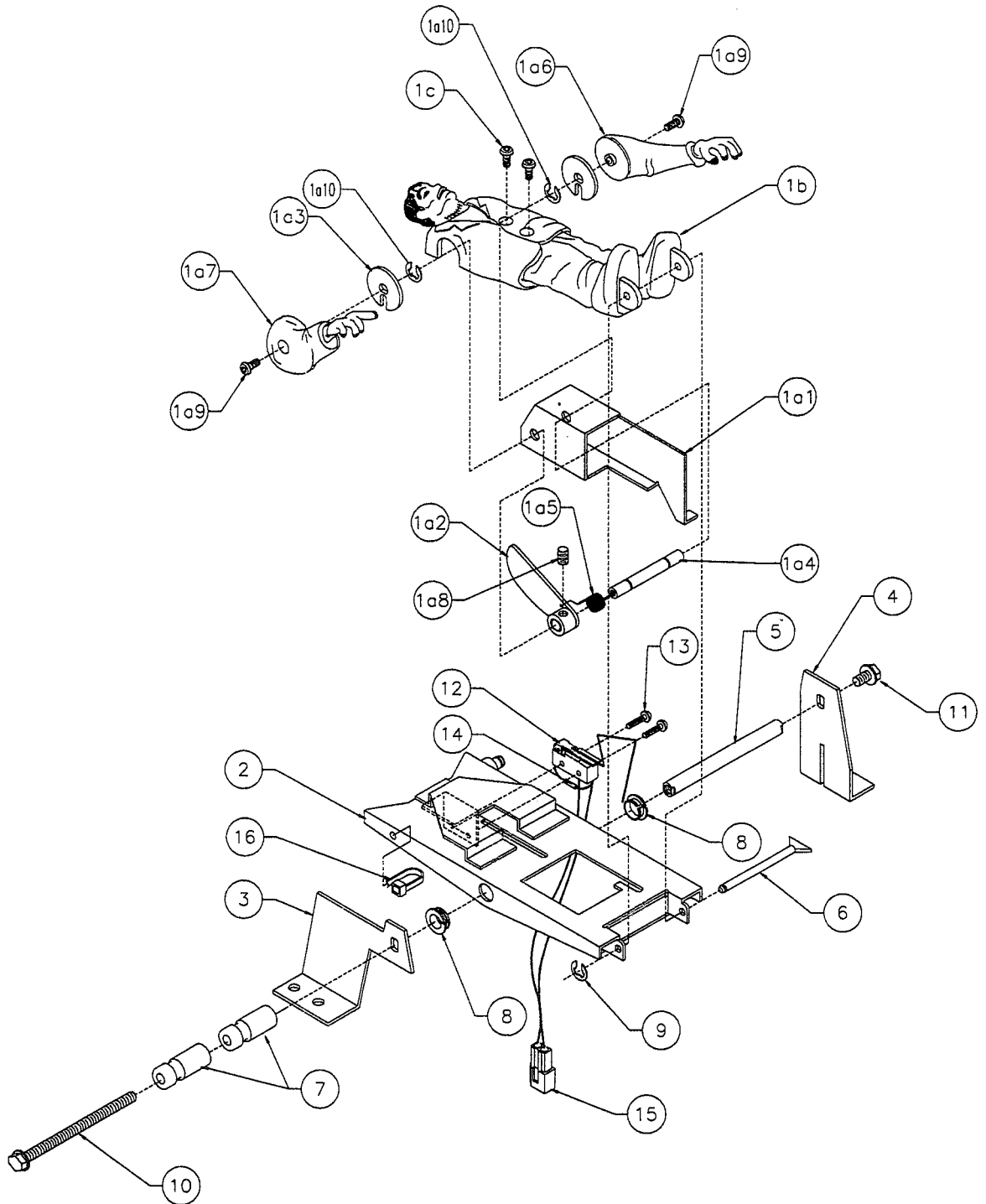

A-22292 Dracula Assembly

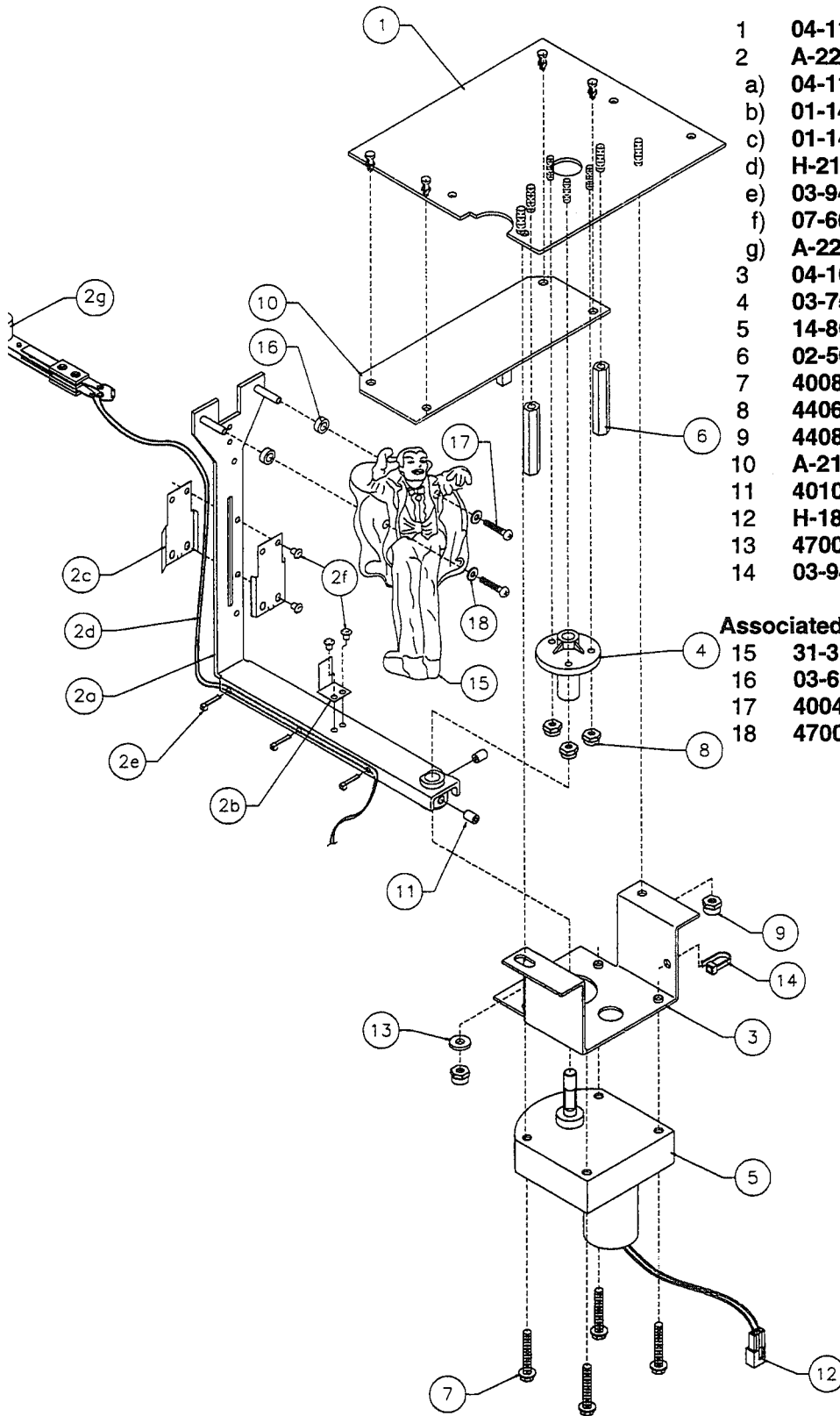

Item	Part Number	Description
1	04-11163	Base Plate
2	A-22409	Dracula Arm Assembly
a)	04-11171	Dracula Mounting Bracket
b)	01-14839	Dracula Mech. - Flap
c)	01-14960	Retainer Clip-Wire
d)	H-21778-18	Cable
e)	03-9454	Ty-Wrap
f)	07-6688-17N	Rivet: 1/8 x 5/32"
g)	A-22411	Dracula Switch Assembly
3	04-10708	Motor Bracket - Defender
4	03-7568	Flipper Bushing
5	14-8034	Motor - Defender
6	02-5049-6	F-F Spacer #8-32 x 1.62"
7	4008-01113-16	Mach. Screw, 8-32 x 1"
8	4406-01119-00	Nut 6-32 ESN
9	4408-01119-00	Nut 8-32 ESN
10	A-21402	Opto Board
11	4010-01082-04	Set Screw, 10-32 x 1/4"
12	H-18601-1	Cable
13	4700-00011-00	FW: 11/64 x 7/16 x 16ga.
14	03-9454	Cable Tie 4" Long

Associated Assemblies:

15	31-3112	Dracula Figure
16	03-6047-7	Spacer
17	4004-01003-10	Mach. Screw: 4-40 x 5/8"
18	4700-00003-00	FW: 1/8 x 9/32 x 21ga.

A-22302 Mummy Assembly

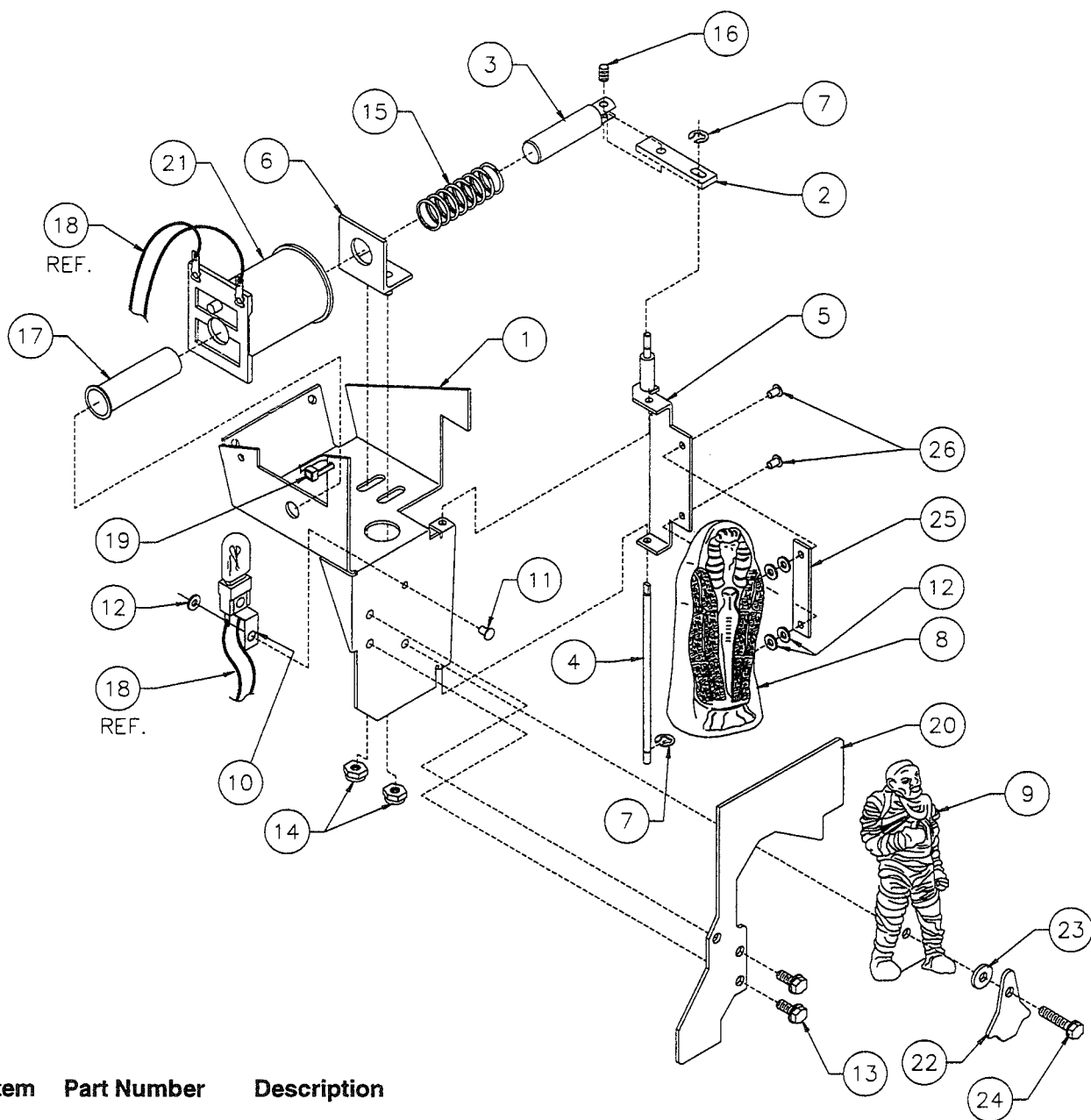

Item	Part Number	Description
1	04-11181.1	Mummy Main Bracket
2	01-14854	Link Arm
3	02-5449	Armature Shaft
4	02-5451	Hinge Pin
5	04-11190.1	Door Bracket
6	04-10910-1	Bracket 5/8" Coil Ctr.
7	20-8712-12	E-Ring, 1/8" Shaft (2)
8	03-9865.1	Mummy Coffin
9	03-9864	Mummy Figure
10	A-17802	Socket & Bulb Assy. (#906)
11	07-6688-18N	Rivet
12	4700-00003-00	FW: 1/8 x 9/32 x 21ga. (5)
13	4008-01113-06	Mach. Screw: 8-32 x 3/8"
14	4408-01119-00	Nut #8-32 ESNA (2)
15	10-399	Spring

Item	Part Number	Description
16	20-9370-1	Roll Pin: 5/32 x 7/16"
17	03-7066	Coil Tubing: 1-3/4"
18	H-22446	Cable
19	03-9454	Ty-Wrap
20	31-3219-11A	Playfield Plastic
21	AE-27-1200	Coil
22	31-3219-38	Playfield Plastic
23	4700-00011-00	FW: 11/64 x 7/16 x 16ga.
24	4008-01168-12	Mach. Screw: 8-32 x 3/4"
25	23-6842	Rubber Pad
26	07-6688-22N	Rivet: 5/16 x 1/8" (2)

A-22422 Monster Mech. Assembly

Item	Part Number	Description
1	A-22404	Motor & Gearbox Assembly
	a) 14-8015	Motor
	b) 03-9222	Pinion Gear
	c) 03-9219	Gear Cluster (3)
	d) 03-9219-2	Gear Cluster
	e) 20-10131-07Y	Metric Screw: M2.6 x 8" (2)
	f) 02-5450	Standoff (3)
	g) 02-5444	Shaft
	h) 02-5443	Drive Shaft
	j) 20-8712-12	E-Ring, 1/8" Shaft (4)
	k) 4700-00004-00	Flat Washer: 9/64 x 3/8 x 21ga.
	m) 4008-01168-04	Mach. Screw: 8-32 x 1/4 Hex Head w/ SEMS (3)
	n) 04-11168	Motor Mounting Bracket
	p) 04-11183	Faceplate
	q) 03-9873	Spacer
2	04-11189.1	Monster Mech. Bracket
3	04-11188	Monster Mech. Crank
4	01-14964	Monster Mech. Link
5	01-8600	Insulator (4)
6	01-8240	Nut Plate 2-56
7	4408-01119-01	Nut 8-32 ESNA
8	4008-01083-04	Set Screw: 8-32 x 1/4"
9	5647-12693-11	Mini Micro Switch
10	5070-09054-00	Diode 1N4004 1.0A.
11	4002-01105-10	Mach. Screw 2-56 x 5/8"
12	20-8712-18	E-Ring 3/16" Shaft
13	H-22008-8	Cable 8"
14	H-22420	Frank Switch Cable
15	03-9454	Cable Tie 4" Long .1 Wide

A-22422 Monster Mech. Assembly

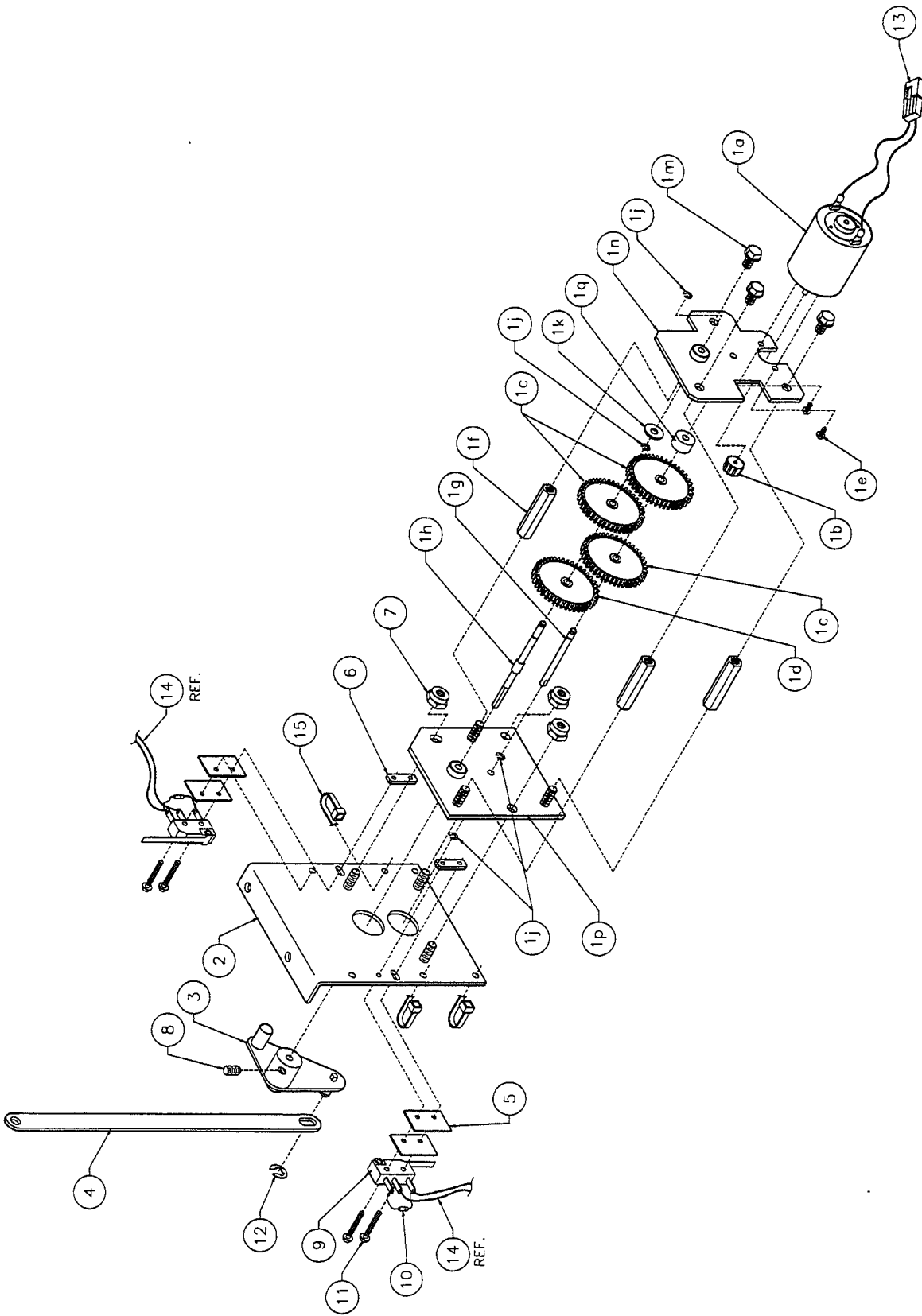

A-22275 Up/Down Target Assembly

Item	Part Number	Description
1	A-22276	Slide Bracket Assembly
	a) 04-11218	Slide Bracket
	b) 07-6688-16N	Rivet: 1/8 x 1/8"
	c) 01-14833	Up/Down Flap
2	04-11167	Cam
3	04-11166	Main Bracket
4	03-9859	Slide Roller
5	03-9860	Roller
6	01-14835	Fish Paper
7	A-22404	Motor & Gearbox Assembly
	a) 14-8015	Motor
	b) 03-9222	Pinion Gear
	c) 03-9219	Gear Cluster
	d) 03-9219-2	Gear Cluster
	e) 20-10131-07Y	Metric Screw: M2.6 x 8"
	f) 02-5450	Standoff
	g) 02-5444	Shaft
	h) 02-5443	Drive Shaft
	j) 20-8712-12	E-Ring 1/8"
	k) 4700-00004-00	Flat Washer: 9/64 x 3/8 x 21ga.
	m) 4008-01168-04	Mach. Screw: 8-32 x 1/4 Hex Head w/ SEMS
	n) 04-11168	Motor Mounting Bracket
	p) 04-11183	Faceplate
	q) 03-9873	Spacer
8	A-22414-1	Standup Target Assembly, Blue
9	03-9835	Pivot Spacer (2)
10	01-8240	Plate Nut #2-56 (2)
11	5647-12639-36	Mini Micro Switch (2)
12	20-8712-18	E-Ring, 3/16" Shaft (4)
13	4404-01119-00	Nut 4-40 ESNA (4)
14	4002-01105-10	Mach. Screw: 2-56 x 5/8"
15	4408-01119-01	Nut 8-32 ESNA
16	4700-00003-00	Flat Washer: 1/8 x 9/32 x 21ga.
17	03-9454	Cable Tie 4" Long
18	01-8657	Bracket Stop
19	23-6534-9	Rubber Protector 3/8"
20	SW-1A-217-4	Standup Target Assembly (2)
21	01-3670	Sw. Curved Plate (3)
22	4700-00123-00	Flat Washer: 7/32 x 7/16 x 18ga.
23	4008-01083-04	Set Screw 8-32
24	H-18600-1	Cable, Gen Motor 2-pin 8"
25	H-22444	Cable, Up Down Bank Target
26	5070-09054-00	Diode 1N4004 1.0A.
27	H-22445	Cable, Left Right Bank Target
28	4004-01005-16	Mach. Screw, 4-40 x 1" (2)

A-22275 up/Down Target Assembly

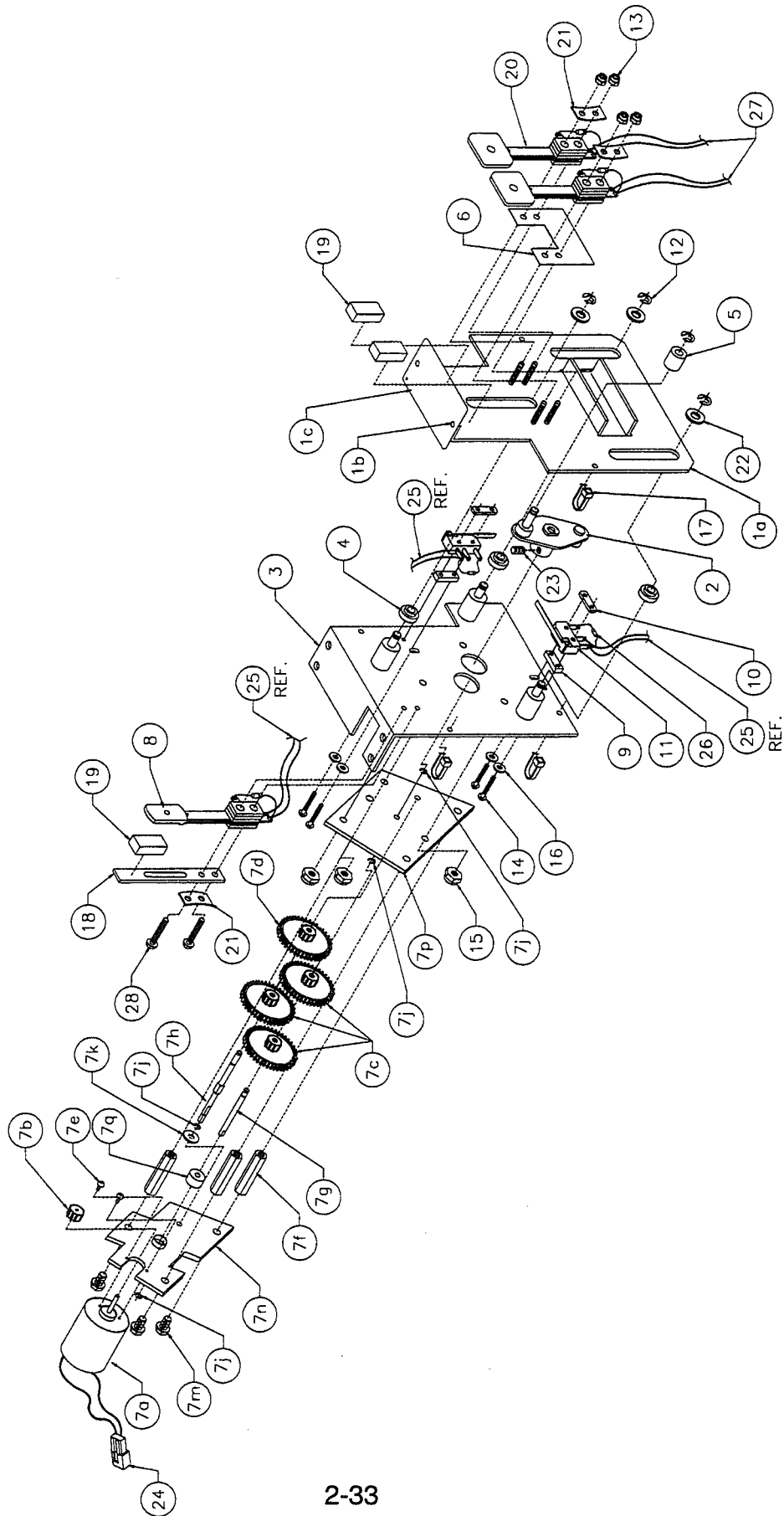

A-22408 Creature Mounting Bracket Assembly

Item	Part Number	Description
1	01-14961	Creature Mounting Bracket
2	03-9866	Creature
3	4408-01119-01	8-32 ESNA Nut
4	4008-01113-06	Mach. Screw: 8-32 x 3/8"

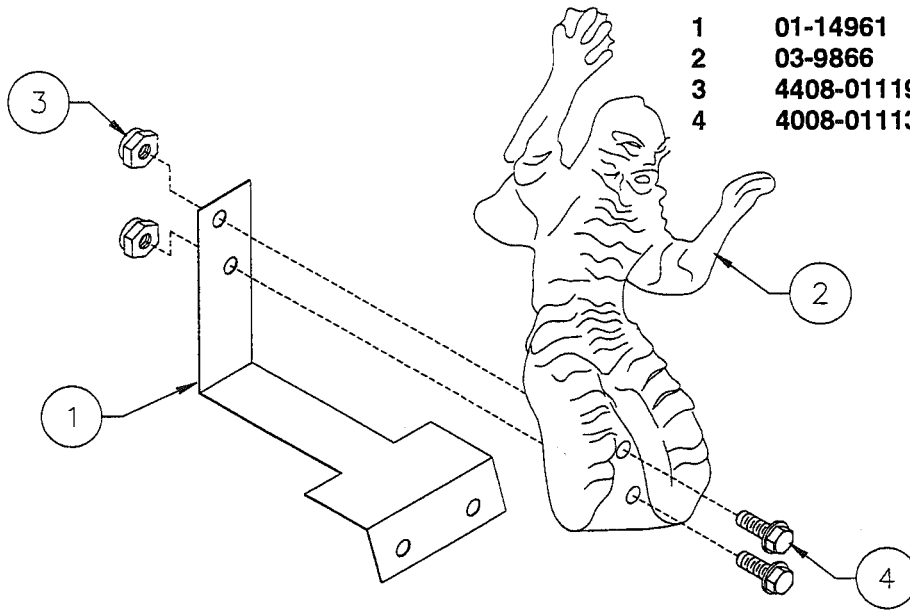

Posts

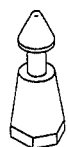

03-8044-12
Mini-Post, Trans. Org.
Qty.: 2

03-8044-13
Mini-Post, Clear
Qty.: 3

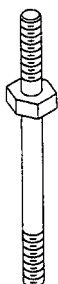

02-4425-1
Post #8-32/#8-32
Qty.: 3

02-4425-2
Post #8-32/#8-32
Qty.: 4



02-5294-18
1/4 Hex. Post 8F/8F, 1.13"
Qty.: 2



02-5295-16
Post M-F 8-32 x 1"
Qty.: 2

02-5295-22
Post M-F 8-32 x 1-3/8"
Qty.: 1



02-4660
Mini-Post Single Bumper
Qty.: 4



02-5296-17
1/4 Hex. Post 8M/8M, 1.06"
Qty.: 4

02-5296-21
1/4 Hex. Post 8M/8M, 1.31"
Qty.: 1

02-5296-28
1/4 Hex. Post 8M/8M, 1.75"
Qty.: 2

02-5296-50
1/4 Hex. Post 8M/8M, 3.13"
Qty.: 1

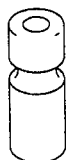

03-9357-13
Post 3/8 X 1.06", Clear
Qty.: 9

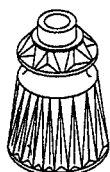

03-8319-12
Post #8 Starred, Tr. Org.
Qty.: 2

03-8319-13
Post #8 Starred, Clear
Qty.: 1

03-8319-18
Post #8 Starred, Tr. Violet
Qty.: 13

03-8319-9
Post #8 Starred, Tr. Red
Qty.: 1



02-5107
Post-Adjusting
Qty.: 2



03-8365-12
Post #8 Trans. Orange
Qty.: 6

03-8365-18
Post #8
Qty.: 2

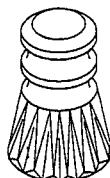

03-8247-12
Bumper Post Double Starred, Tr. Org.
Qty.: 1

03-8247-18
Bumper Post Double Starred, Tr. Violet
Qty.: 3

A-20871 Power Interface Assembly

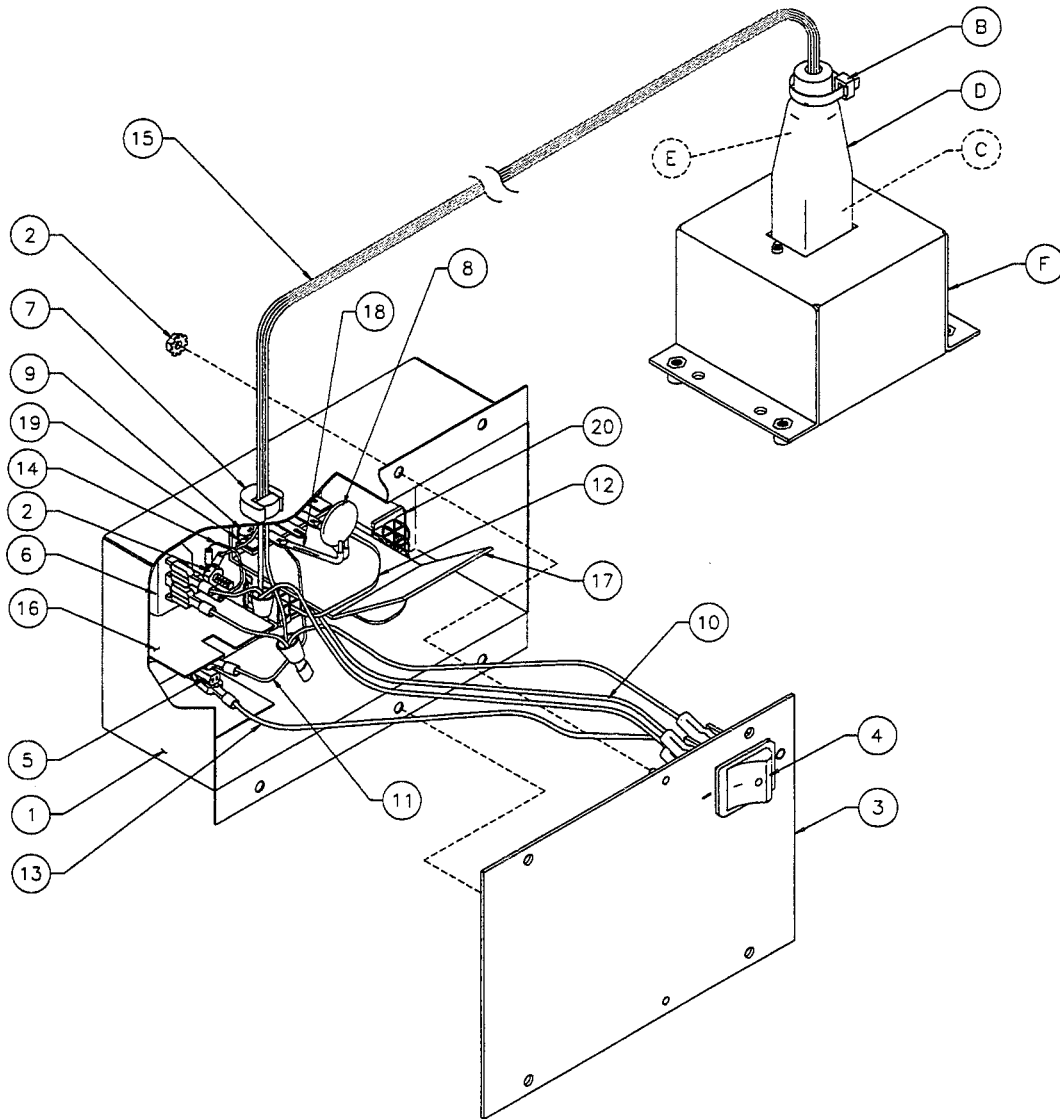

Item	Part Number	Description	Item	Part Number	Description
A	A-20872	Power Control Chassis Assembly	14)	H-17542	Ground Jumper Grn/Yel Cable
1)	04-10292	Power Control Chassis Box	15)	5797-13940-01	Jumper Cable
2)	4406-01128-00	Nut #6-32 KEPS (3)	16)	01-10623	Insulator, Thermistor
3)	01-12294	Switch Mounting Plate Assembly	17)	01-12299	Insulator, Terminal Strip
4)	5642-13935-00	Power Switch	18)	RM-21-06	#18 Vinyl Fgls
5)	5733-14734-00	Fuse Holder Panel (5x20mm)	19)	5822-13865-00	Terminal Strip 3-CKT 2-Mtg.
6)	5851-13867-00	Outlet-IEC Conn. 237 Socket	20)	H-18050	Jumper Cable, Transformer Prog
7)	03-8712	Strain Relief Bushing	B	03-7933	Ty-Wrap Nylon
8)	5016-12978-00	Thermistor 8A., 2.5R25	C	5045-14007-00	Capacitor, 1µF 275v
9)	4006-01003-10	Mach. Screw, #6-32 x 5/8"	D	23-6776-4	Heat Shrink
10)	H-17992	Jumper Cable Neutral Sw/1FC	E	RM-21-06	#18 Vinyl Sleeving
11)	H-17543	Hot Jumper Black Cable	F	A-20873	Line Filter Entry Chassis
12)	H-17546	Jumper Interface Hot Black Cable			
13)	H-17545	Jumper Switch/Fuse Black Cable			

Upper Playfield Parts

Item Number	Part Number	Description	Item Number	Part Number	Description
1	A-22429-1 AE-24-900	Auto-fire Kicker Assy Coil	22	A-22449 AE-30-2000	Left Eject Assy
2	A-19963 AE-26-1500 A-18617-1 A-18618-1	Complete Ball Trough Coil LED PC Board Photo Trans PC Board	23	A-17811 A-17801 A-22207-2	Slingshot Assy Count Switch Assy Coil & Bracket Assy
3	A-22603-R FL-11629 20-10110-5	Right Flipper Assy Coil Flipper Bat & Shaft	24	A-22473-2 01-14819	Left Flipper Ball Guide Ball Guide #1
4	A-22473-1 01-14819	Right Flipper Ball Guide Ball Guide #1	25	A-15849-L-2 FL-11629 20-10110-5	Left Flipper Assy Coil Flipper Bat & Shaft
5	A-17811 A-17801 A-22206-2	Slingshot Assy Count Switch Assy Coil & Bracket Assy	26	A-13204-50065 31-3221.1	Screened Bottom Arch Assy Screened Bottom Arch
6	A-22256	Right Wire Ramp	27	A-22481 12-7436.1	Rollunder Gate Assy Wireform
7	A-20499-9	Standup Target - Red	28	A-22434 04-11200 31-3115	Dr. Frank Bracket Assy Bracket Dr. Frank Figurine
8	A-22292 A-22409 A-22411 14-8034 A-21402 31-3112 A-22436	Dracula Assy Dracula Arm Assy Dracula Switch Assy Motor Defender Switch PC Brd Dracula Figurine Dracula Coffin Assy	29	A-22413 A-22437 23-6694-3	Center Ramp Assy Rollunder Gate Assy Black Rubber Ring-5/16"
9	A-22295 A-22437 23-6766	Right Ramp Assy Rollunder Gate Assy Ball Guide Bumper	30	A-22268 A-19308	Spin Target Assy Wire Shaft & Target Assy
10	A-22266 AE-25-1000	Popper Monster Assy Coil	31	A-22275 A-22404 14-8015 A-22414-1 SW-1A-217-4	Up/Down Target Assy Motor & Gear Box Assy Motor Standup Target - Blue Standup Target - Red
11	B-9414-5 A-22205-2 A-12030-3	Jet Bumper Assy Coil & Bracket Leaf Switch Assy			
12	A-19001 12-6657.1-L	Ball Gate Special Assy Ball Gate Wire			
13	A-22302 03-9864 03-9865.1 AE-27-1200 23-6842	Mummy Assy Mummy Figurine Mummy Coffin Coil Rubber Pad			
14	A-17797-1 12-6657.1-L	Ball Gate Special Assy Ball Gate Wire			
15	A-22425 AE-26-1500 31-3116-1 31-3116-2	Bride Mechanism Assy Coil Bride Head Bride Body			
16	A-22469 A-22472 04-10091.1	Playfield Plastic #4 Dome Sub-assy Bulb & Socket Assy			
17	A-18019-15	Standup Trgt - Orange			
18	A-22470 A-22472 04-10091.1	Playfield Plastic #5 Dome Sub-assy Bulb & Socket			
19	A-22422 A-22404 14-8015 A-22297 31-3103 A-22293	Monster Mech Assy Motor & Gear Box Assy Motor Monster Table Assy Monster Figurine Up/Down Post Assy			
20	A-22257	Left Wire Ramp			
21	A-18530-1	Standup Target - Blue			

Not Shown:

A-22405	Back Panel Assembly
01-14959	Playfield Brace
01-14613	Backboard Brace
31-3219-1A	Playfield Plastic
31-3219-22A	Playfield Plastic
20-9658-1	PC Board Standoff
A-17802	Socket & Bulb
A-17826	Socket & Bulb
03-8633	Level Mount
20-9691	Level
31-3114	Igor Figurine

*The *MONSTER BASH* hardcoat playfield does not require a full Mylar. However, mylars can be purchased through your local WILLIAMS Distributor.

Upper Playfield Parts

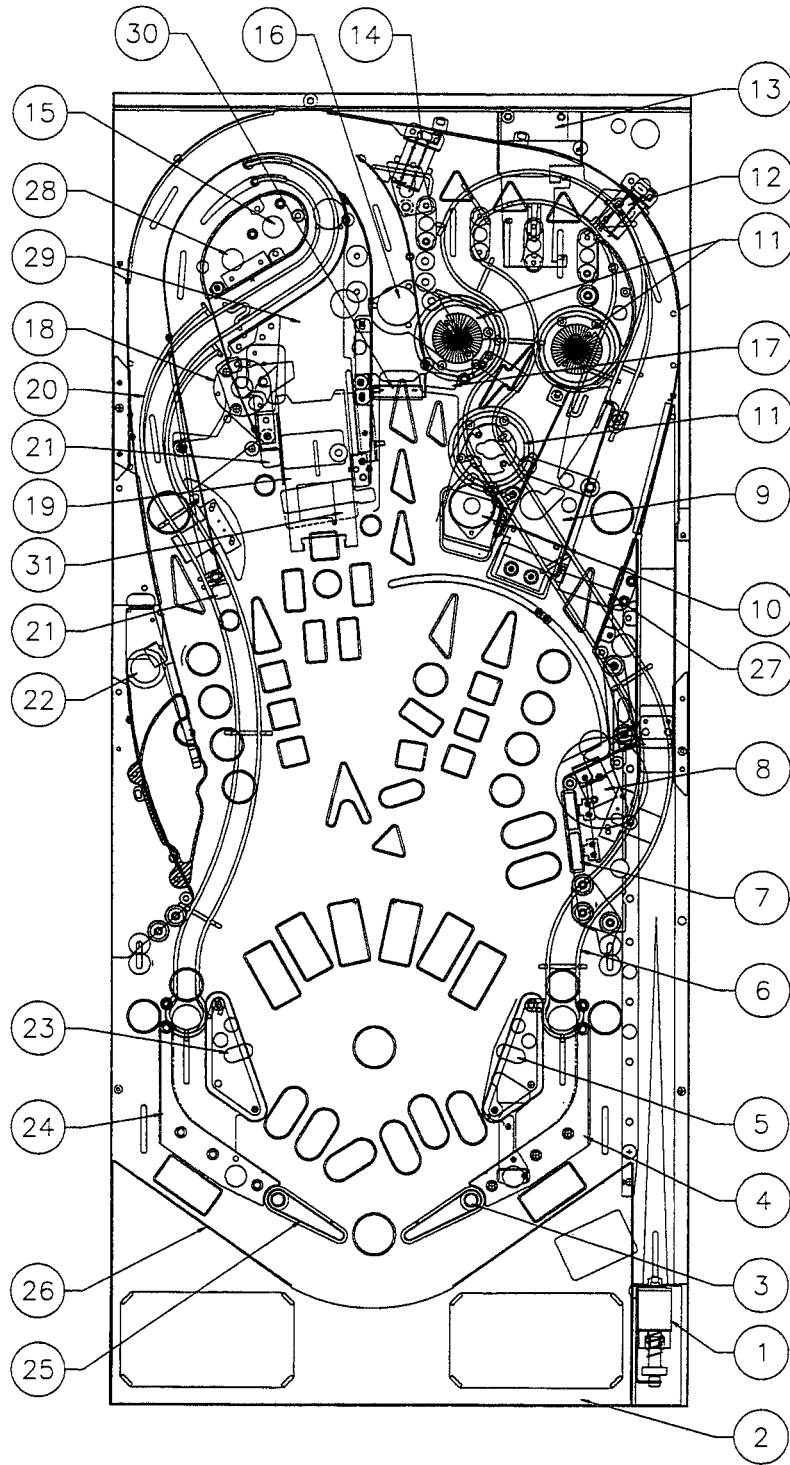

Lower Playfield Parts

Item	Part Number	Description
1	01-11781	Support Bracket (2)
2	A-19963	Ball Trough Assembly
3	A-22603-R	Flipper Assembly
4	A-15849-L-2	Flipper Assembly
5	04-12336	6-Lamp PCB Assembly
6	A-22206-2	Coil & Bracket Assembly, R.
7	04-12335	6-Lamp PCB Assembly
8	A-20246	10-Opto PCB Assembly
9	A-22293	Up Down Post Assembly
10	A-22292	Dracula Assembly
11	04-12334	17-Lamp PCB Assembly
12	A-15542	Motor EMI Assembly (2)
13	A-22266	Popper Assembly
14	A-22205-2	Jet Coil & Bracket Assy. (3)
15	04-12332	3-Lamp PCB Assembly
16	A-17796-1	Ball Gate Actuator Assy. (2)
17	A-22425	Bride Mechanism Assembly
18	A-17749.1-1	Slide Playfield Assy., L.
19	A-22275	Up/Down Target Assy.
20	04-12337	6-Lamp PCB Assembly
21	A-22449	Eject Assembly
22	04-12339	4-Lamp PCB Assembly
23	04-12338	4-Lamp PCB Assembly
24	A-22408	Creature Mounting Bracket
25	A-16120	DC Motor Control Assy. (4 Way)
26	A-22207-2	Coil & Bracket Assembly, L.
27	A-17749.1-2	Slide Playfield Assy., R.
28	A-22149.1	Auto Adjust Eddy Sensor PCB (2)
29	03-9862	Creature Lagoon Plastic

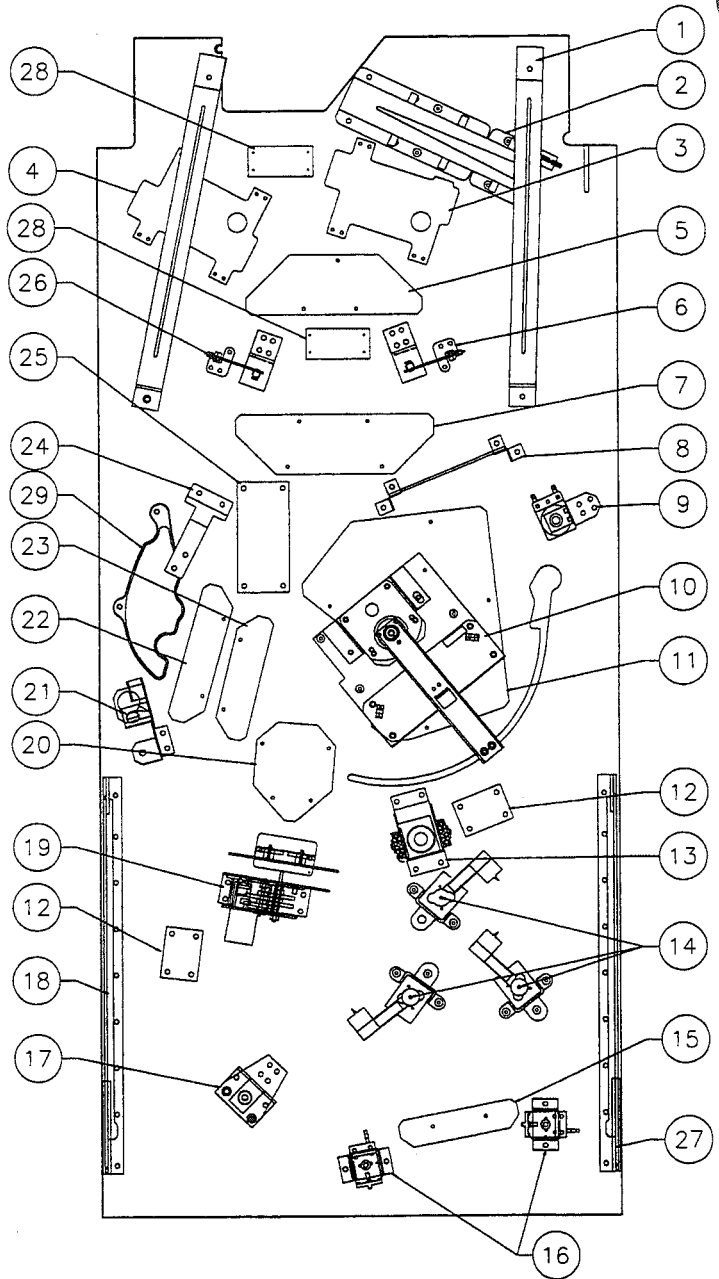

Underside of playfield, viewed in raised position.

Rubber Parts

Item No.	Part No.	Description	Quantity
A	23-6556	Black Rubber Bumper Sleeve	3
B	23-6641	Black Rubber Bumper	11
C	23-6694-1	Black Rubber Grommet 3/32"	7
D	23-6694-3	Black Rubber Ring 5/16"	6
E	23-6694-8	Black Rubber Ring 1-1/2"	3
F	23-6694-10	Black Rubber Ring 2-1/2"	2
G	23-6695	Black Rubber Flipper Ring	2
H	23-6766	Blue Rubber Bumper	2
	01-14844	Guard	2
I	23-6766	Blue Rubber Bumper	1
	04-10253-1	Guard	1

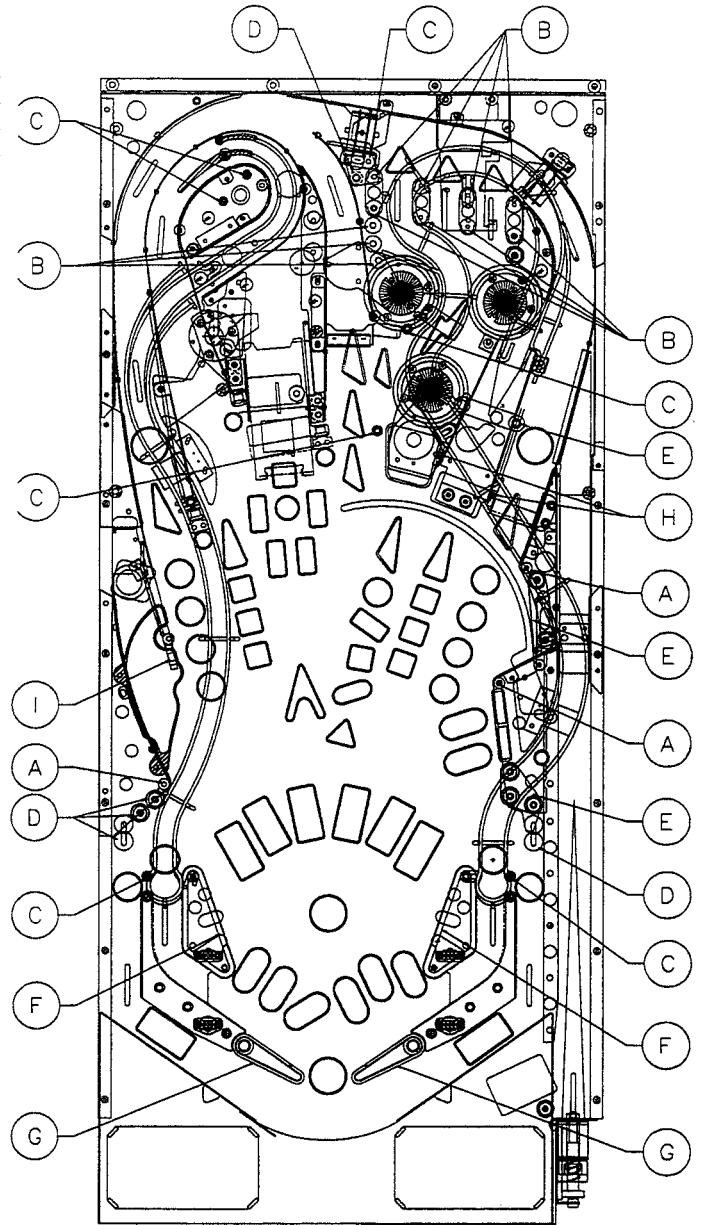

Ball Guides

Item No.	Part No.	Description
1	12-7433	Wire Ball Guide #3
2	04-11161	Ball Guide #9
3	12-7432	Wire Ball Guide #2
4	A-22464	Ball Guide #3
5	04-11159.1	Ball Guide #5
6	04-11158.1	Ball Guide #4
7	04-11160	Ball Guide #8
8	12-7374.1	Wire Ball Guide
9	A-22463	Ball Guide #2
10	12-7439	Wire Ball Guide #1

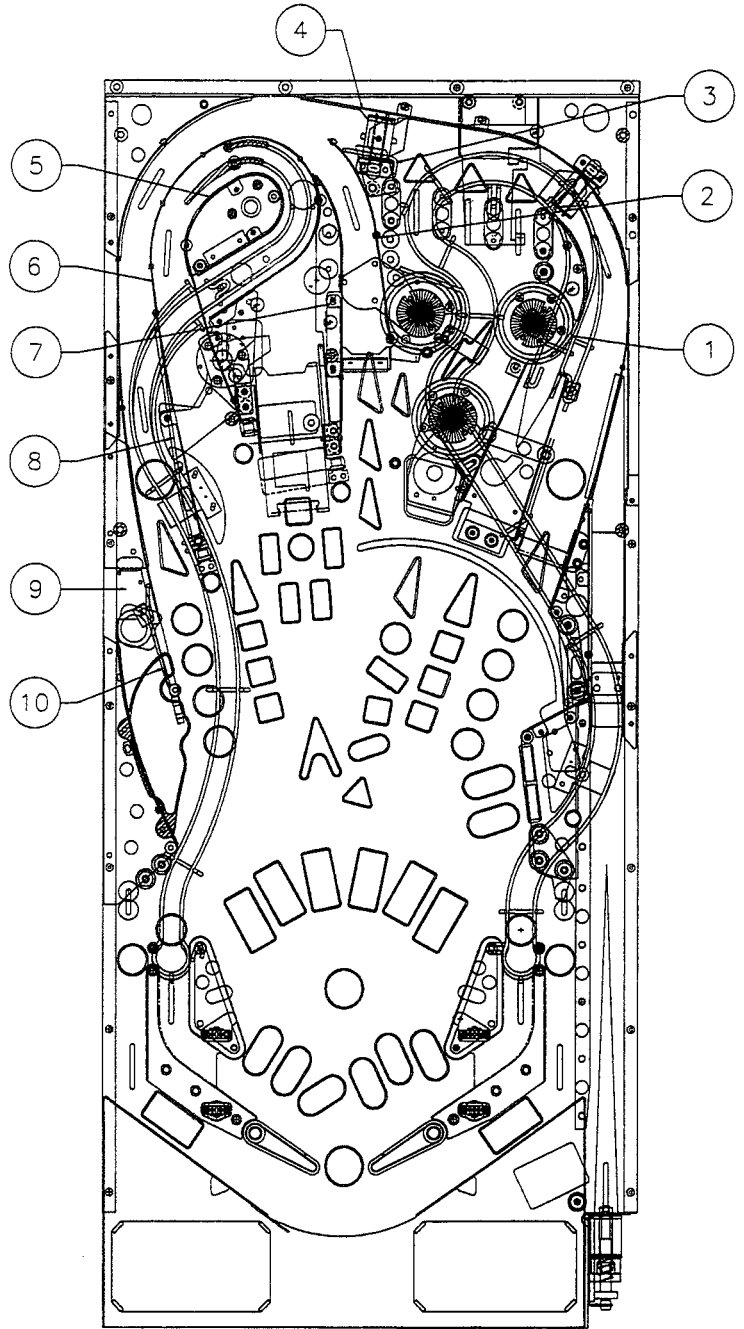

Ramps

Item	Part Number	Description
1	A-22295	Right Ramp Assembly
2	A-22256	Right Wire Ramp
3	A-22257	Left Wire Ramp
4	A-22413	Center Ramp Assembly

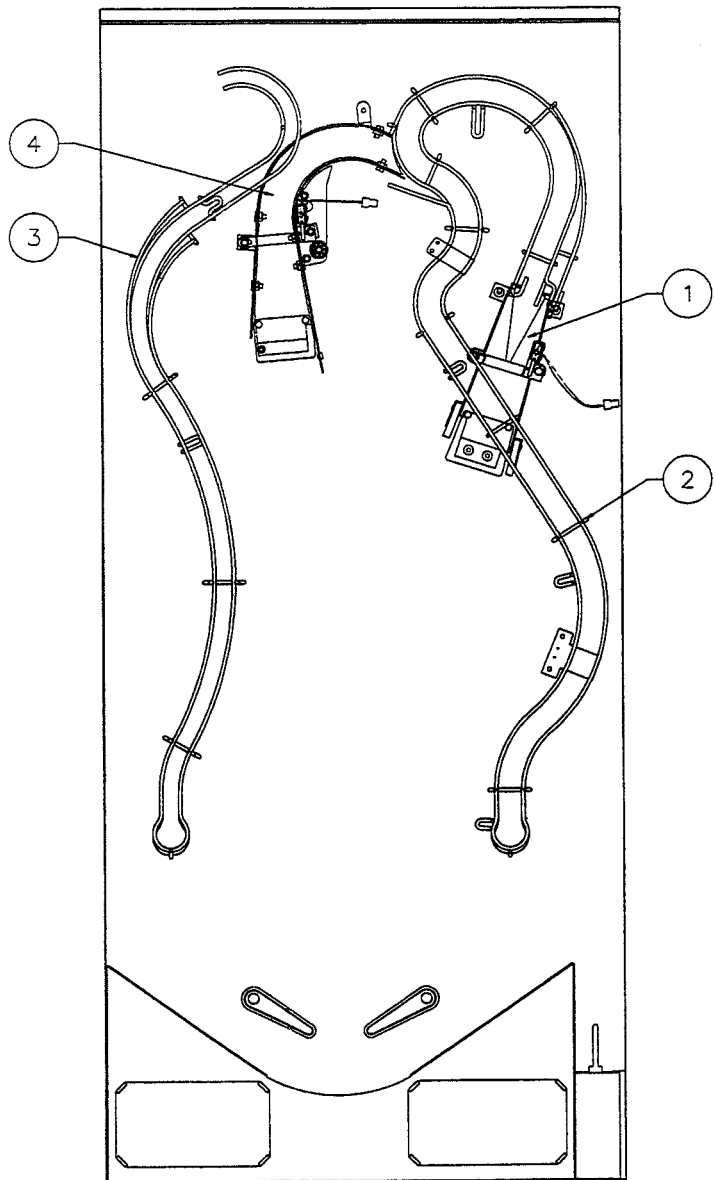

Lamp Locations

Item Number	Lamp Assembly Part Number	Bulb Type	Bulb Part Number	Socket Part Number	Description
11	04-12334	#555	24-8768	24-8767	MONSTER MOSH PIT
12	04-12334	#555	24-8768	24-8767	HALF MOON (2)
13	04-12334	#555	24-8768	24-8767	FRANKENSTEIN ARROW
14	04-12334	#555	24-8768	24-8767	DRAC-ATTACK
15	04-12334	#555	24-8768	24-8767	EXTRA BALL
16	04-12334	#555	24-8768	24-8767	MONSTERS OF ROCK
17	04-12334	#555	24-8768	24-8767	MONSTER BASH
18	04-12334	#555	24-8768	24-8767	MUMMY MAYHEM
21	04-12334	#555	24-8768	24-8767	RIGHT RAMP ARROW
22	A-17807	#44	24-6549	Not Sold Separate	ROCK C.D.
23	A-17835	#44	24-6549	Not Sold Separate	RIGHT RETURN
24	04-12334	#555	24-8768	24-8767	FULL MOON FEVER (2)
25	04-12334	#555	24-8768	24-8767	RIGHT GARGLE
26	04-12334	#555	24-8768	24-8767	RIGHT WARM UP
27	04-12334	#555	24-8768	24-8767	RIGHT PRIMP
28	A-17835	#44	24-6549	24-8767	RIGHT LOOP ARROW
31	04-12334	#555	24-8768	24-8767	QUARTER MOON (2)
32	A-17835	#44	24-6549	Not Sold Separate	LEFT BLUE TARGET
33	A-17835	#44	24-6549	Not Sold Separate	TOMB TREASURE
34	04-12334	#555	24-8768	24-8767	DRACULA STANDUP TOP
35	04-12332	#555	24-8768	24-8767	RIGHT TOP LANE
36	04-12332	#555	24-8768	24-8767	MIDDLE TOP LANE
37	04-12332	#555	24-8768	24-8767	LEFT TOP LANE
38	04-12334	#555	24-8768	24-8767	DRACULA STANDUP BOTTOM
41	A-17835	#44	24-6549	Not Sold Separate	LEFT RETURN
42	A-17807	#44	24-6549	Not Sold Separate	LEFT OUTLANE
43	04-12334	#555	24-8768	24-8767	THREE-QUARTER MOON (2)
44	A-17835	#44	24-6549	Not Sold Separate	RIGHT BLUE TARGET
45	04-12338	#555	24-8768	24-8767	LEFT RAMP ARROW
46	04-12338	#555	24-8768	24-8767	LEFT PRIMP
47	04-12338	#555	24-8768	24-8767	LEFT WARM UP
48	04-12338	#555	24-8768	24-8767	LEFT GARGLE
51	04-12336	#555	24-8768	24-8767	GUITAR
52	04-12336	#555	24-8768	24-8767	DRUMS
53	04-12336	#555	24-8768	24-8767	BASS GUITAR
54	04-12336	#555	24-8768	24-8767	KEYBOARD
55	04-12336	#555	24-8768	24-8767	MICROPHONE
56	04-12336	#555	24-8768	24-8767	SAXOPHONE
57	A-17807	#44	24-6549	Not Sold Separate	CENTER LOOP ARROW 3
58	A-17807	#44	24-6549	Not Sold Separate	CENTER BLUE TARGET
61	04-12335	#555	24-8768	24-8767	CREATURE
62	04-12335	#555	24-8768	24-8767	BRIDE
63	04-12335	#555	24-8768	24-8767	FRANKENSTEIN
64	04-12335	#555	24-8768	24-8767	MUMMY
65	04-12335	#555	24-8768	24-8767	WOLFMAN
66	04-12335	#555	24-8768	24-8767	DRACULA
67	A-17807	#44	24-6549	Not Sold Separate	RIGHT OUTLANE
68	A-17807	#44	24-6549	Not Sold Separate	SHOOT AGAIN
71	04-12337	#555	24-8768	24-8767	LEFT FRANKENSTEIN ARM
72	04-12337	#555	24-8768	24-8767	LEFT FRANKENSTEIN LEG
73	04-12337	#555	24-8768	24-8767	FRANKENSTEIN TORSO
74	04-12337	#555	24-8768	24-8767	FRANKENSTEIN HEAD
75	04-12337	#555	24-8768	24-8767	RIGHT FRANKENSTEIN LEG
76	04-12337	#555	24-8768	24-8767	RIGHT FRANKENSTEIN ARM
77	A-17807	#44	24-6549	Not Sold Separate	LEFT LOOP ARROW
78					NOT USED
81	04-12339	#555	24-8768	24-8767	MUCK
82	04-12339	#555	24-8768	24-8767	SEAWEED
83	04-12339	#555	24-8768	24-8767	ALGAE
84	04-12339	#555	24-8768	24-8767	POND SCUM
85	A-17835	#44	24-6549	Not Sold Separate	CENTER LOOP ARROW 2
86	A-17835	#44	24-6549	Not Sold Separate	CENTER LOOP ARROW 1
87	20-9663-B-4	----	----	----	LAUNCH BUTTON
88	20-9663-16	----	----	----	START BUTTON

Lamp Locations

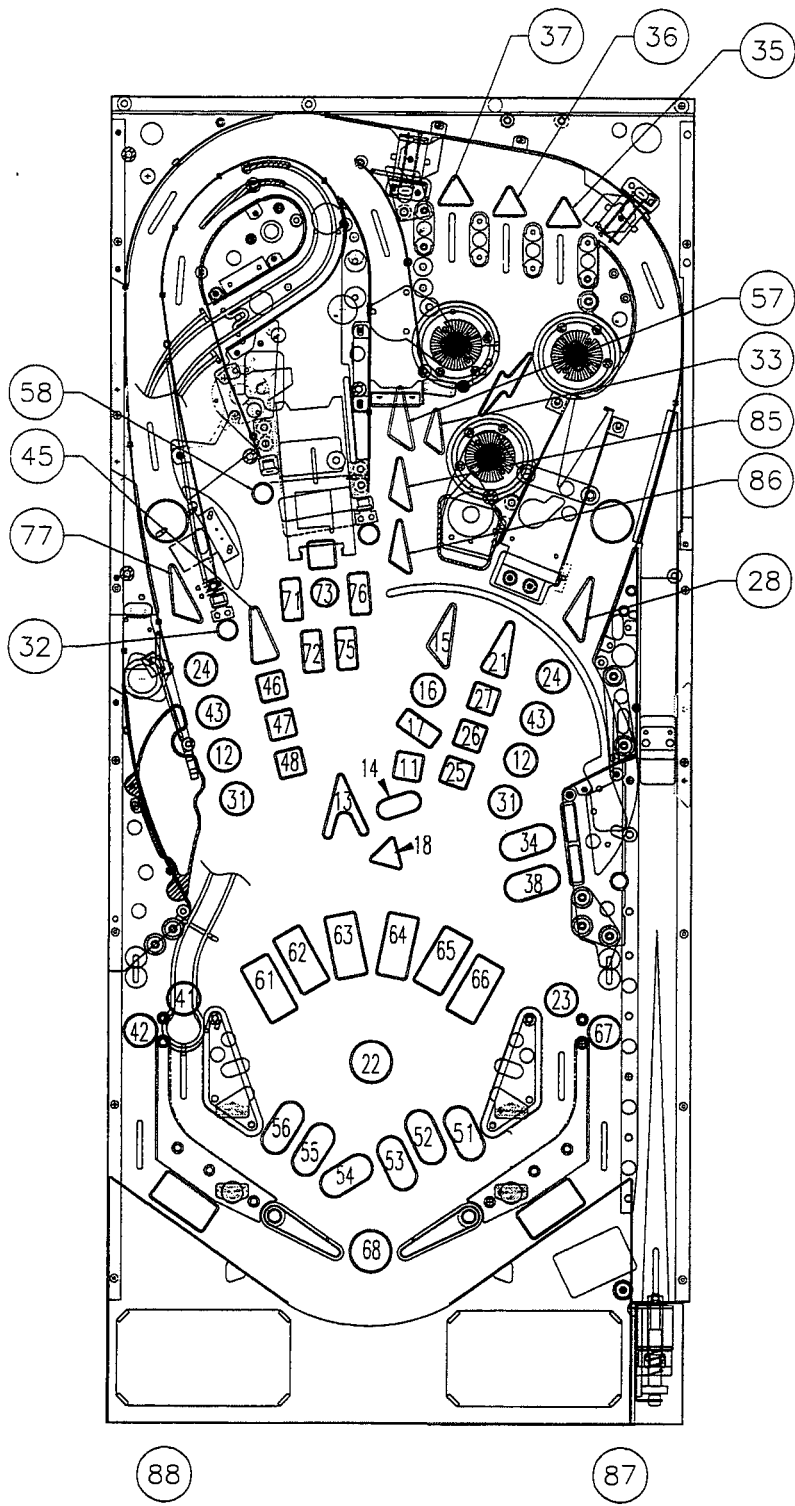

Solenoid/Flasher Locations

Item Number	Assembly Part Number	Coil or Flasher Part Number	Description
01	A-22429-1	AE-24-900	AUTO PLUNGER
02	A-22425	AE-26-1500	BRIDE POST
03	A-22302	AE-27-1200	MUMMY COFFIN
04			NOT USED
05	A-17796	A-14406	LEFT GATE
06	A-17796	A-14406	RIGHT GATE
07			NOT USED
08	A-22293	AE-27-1200	RAMP LOCK POST
09	A-19963	AE-26-1500	TROUGH EJECT
10	A-22207-2	AE-26-1200	LEFT SLINGSHOT
11	A-22206-2	AE-26-1200	RIGHT SLINGSHOT
12	A-22205-2	AE-26-1200	LEFT JET BUMPER
13	A-22205-2	AE-26-1200	RIGHT JET BUMPER
14	A-22205-2	AE-26-1200	BOTTOM LET BUMPER
15	A-22449	AE-30-2000	LEFT EJECT
16	A-22266	AE-25-1000	RIGHT POPPER
17	A-17802	#906 (2)	WOLFMAN FLASHERS - BACK PANEL
17	----	#906	WOLFMAN FLASHER - INSERT PANEL
18	A-17983	#89	BRIDE FLASHER - PLAYFIELD
18	----	#906	BRIDE FLASHER - INSERT PANEL
19	04-10091.1	#906 (2)	FRANKENSTEIN FLASHERS - PLAYFIELD
19	----	#906	FRANKENSTEIN FLASHER - INSERT PANEL
20	A-17983	#89	DRACULA COFFIN FLASHER - PLAYFIELD
20	----	#906	DRACULA COFFIN FLASHER - INSERT PANEL
21	A-17802	#906 (2)	CREATURE FLASHERS - PLAYFIELD
22	A-17802	#906 (2)	JETS/MUMMY FLASHERS - PLAYFIELD
22	----	#906	JETS/MUMMY FLASHER - INSERT PANEL
23	----	#906	RIGHT POPPER FLASHER - PLAYFIELD
24	A-17802	#906	FRANK ARROW FLASHER - PLAYFIELD
25	A-17802	#906	MONSTERS OF ROCK FLASHER - PLAYFIELD
25	----	#906	MONSTERS OF ROCK FLASHER - INSERT PANEL
26	A-17802	#906 (2)	WOLFMAN LOOP FLASHERS - PLAYFIELD
27	A-22404	14-8015	FRANK MOTOR
28	A-22404	14-8015	UP/DOWN BANK MOTOR

Flippers

Item	Assembly Part Number	Coil Part Number	Description
29-30	A-22603-R	FL-11629	LOWER RIGHT FLIPPER
31-32	A-15849-L-2	FL-11629	LOWER LEFT FLIPPER
33-34			NOT USED
35-36			NOT USED

Dracula Motor Circuits

Item	Assembly Part Number	Motor Number	Description
37	A-22292	14-8034	DRACULA MOTOR FORWARD
38			DRACULA MOTOR BACKWARD

General Illumination

Item	Bulb Part Number	Bulb Type	Description
01	24-6549	#44	BOTTOM PLAYFIELD
02	24-6549	#44	TOP RIGHT PLAYFIELD
03	24-6549	#44	TOP LEFT PLAYFIELD
04	24-8768	#555	TOP INSERT PANEL
05	24-8768	#555	BOTTOM INSERT PANEL

24-6549 = #44 bulb	24-8768 = #555 bulb
24-8704 = #89 bulb	24-8802 = #906 bulb

Solenoid/Flasher Locations

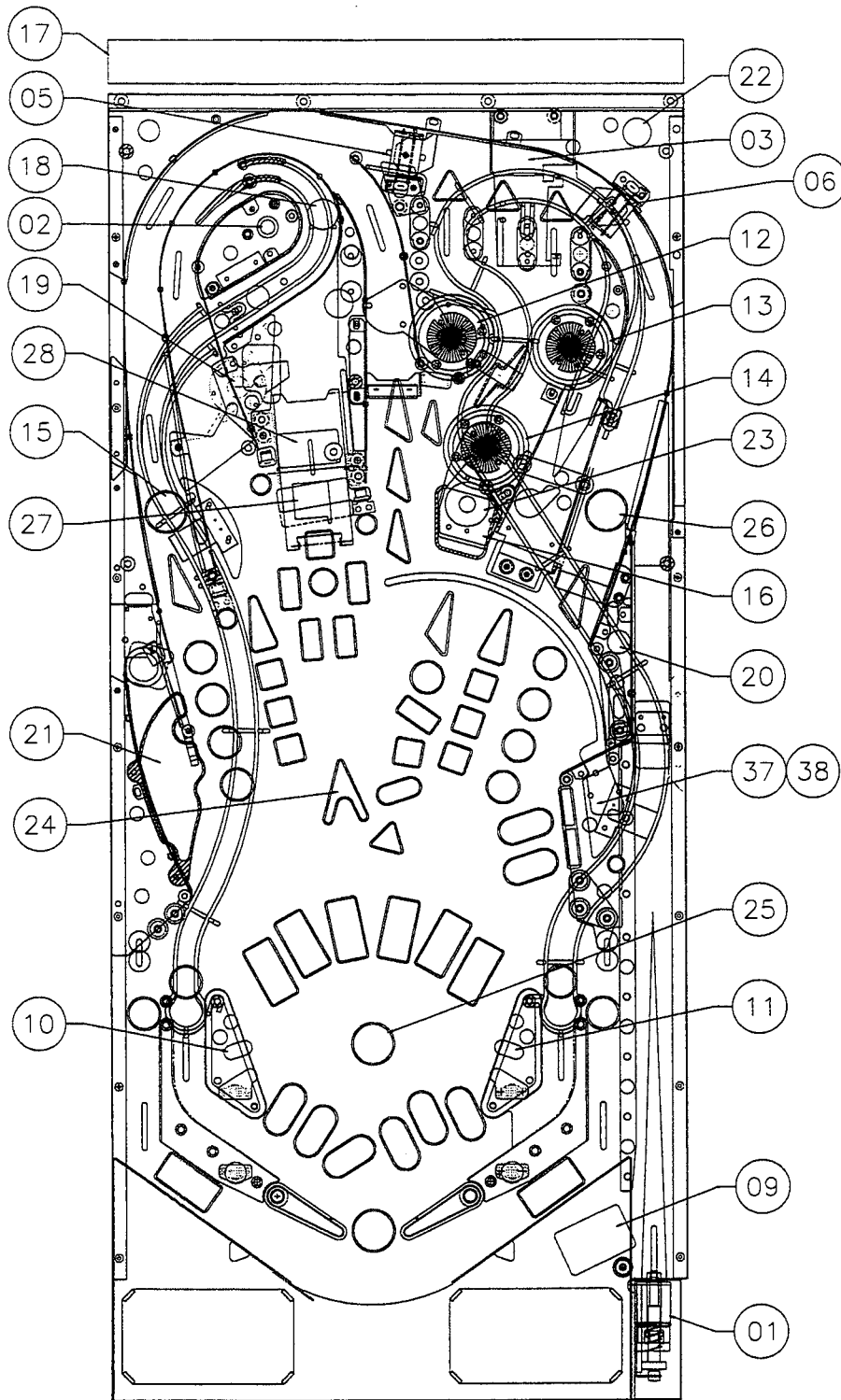

Switch Locations

Item Number	Switch Assembly Part Number <u>OR</u> Opto Assembly Part Number	Switch Part Number	Description
F1	----	SW-1A-194	*LOWER RIGHT FLIPPER E.O.S.
F2	A-17316	----	*LOWER RIGHT FLIPPER CABINET
F3	----	SW-1A-194	*LOWER LEFT FLIPPER E.O.S.
F4	A-17316	----	*LOWER LEFT FLIPPER CABINET
F5	NOT USED	NOT USED	UPPER RIGHT FLIPPER E.O.S
F6	NOT USED	NOT USED	UPPER RIGHT FLIPPER CABINET
F7	A-22268	5647-12693-24	CENTER SPINNER
F8	NOT USED	NOT USED	UPPER LEFT FLIPPER CABINET
11	20-9663-B-4	----	LAUNCH BUTTON
12	A-20499-9	----	DRACULA STANDUP TOP
13	20-9663-16	----	START BUTTON
14	----	04-10346	*PLUMB BOB TILT
15	A-20499-9	----	DRACULA STANDUP BOTTOM
16	A-17813	5647-12693-19	LEFT OUTLANE
17	A-17813	5647-12693-19	RIGHT RETURN
18	A-17791	5467-12693-32	SHOOTER LANE
21	A-17238	----	*SLAM TILT
22	----	5643-09268-00	*COIN DOOR CLOSED
23	A-18019-15	----	TOMB TREASURE
24	----	5643-15190-00	*ALWAYS CLOSED
25	A-22411	----	DRACULA TARGET
26	A-17813	5647-12693-19	LEFT RETURN
27	A-17813	5647-12693-19	RIGHT OUTLANE
28	----	5647-12693-66	LEFT EJECT
31	A-18617-1 (LED) A-18618-1 (PHOTO TRANS)	----	TROUGH ELECT
32	A-18617-1 (LED) A-18618-1 (PHOTO TRANS)	----	TROUGH BALL 1
33	A-18617-1 (LED) A-18618-1 (PHOTO TRANS)	----	TROUGH BALL 2
34	A-18617-1 (LED) A-18618-1 (PHOTO TRANS)	----	TROUGH BALL 3
35	A-18617-1 (LED) A-18618-1 (PHOTO TRANS)	----	TROUGH BALL 4
36	A-16908 (LED) A-16909 (PHOTO TRANS)	----	RIGHT POPPER
37	NOT USED	NOT USED	NOT USED
38	NOT USED	NOT USED	NOT USED
41	NOT USED	NOT USED	NOT USED
42	A-16908 (LED) A-16909 (PHOTO TRANS)	----	LEFT FLIPPER OPTO
43	A-16908 (LED) A-16909 (PHOTO TRANS)	----	RIGHT FLIPPER OPTO
44	A-18530-1	----	LEFT BLUE TARGET
45	A-18530-1	----	CENTER BLUE TARGET
46	A-22414-1	----	RIGHT BLUE TARGET
47	A-17064	----	LEFT FLIPPER PROXIMITY SENSOR
48	A-17064	----	RIGHT FLIPPER PROXIMITY SENSOR
51	A-17801	A-17800 (KICK) A-17794 (SCORE)**	LEFT SLINGSHOT
52	A-17801	A-17800 (KICK) A-17794 (SCORE)**	RIGHT SLINGSHOT
53	A-12030-3	A-16443-1	LEFT JET BUMPER
54	A-12030-3	A-16443-1	RIGHT JET BUMPER
55	A-12030-3	A-16443-1	BOTTOM JET BUMPER
56	A-17813	5647-12693-19	LEFT TOP LANE
57	A-17813	5647-12693-19	CENTER TOP LANE
58	A-17813	5647-12693-19	RIGHT TOP LANE
61	A-17813	5647-12693-19	LEFT LOOP LOW
62	A-17813	5647-12693-19	LEFT LOOP HIGH
63	A-22481	5647-12693-36	RIGHT LOOP LOW
64	A-17813	5647-12693-19	RIGHT LOOP HIGH
65	A-17813	5647-12693-19	CENTER LOOP
66	A-17813	5647-12693-19	LEFT RAMP ENTER
67	----	5647-12693-13	LEFT RAMP EXIT

Switch Locations

Item Number	Switch Assembly Part Number <u>OR</u> Opto Assembly Part Number	Switch Part Number	Description
68	A-22437	5647-12693-24	CENTER RAMP ENTER
71	A-22437	5647-12693-24	RIGHT RAMP ENTER
72	-----	5647-12693-24	RIGHT RAMP EXIT
73	-----	5647-12693-21	RIGHT RAMP LOCK
74	A-21402	-----	DRACULA POSITION 5
75	A-21402	-----	DRACULA POSITION 4
76	A-21402	-----	DRACULA POSITION 3
77	A-21402	-----	DRACULA POSITION 2
78	A-21402	-----	DRACULA POSITION 1
81	-----	5647-12693-36	UP/DOWN BANK UP
82	-----	5647-12693-36	UP/DOWN BANK DOWN
83	-----	5647-12693-11	FRANK TABLE DOWN
84	-----	5647-12693-11	FRANK TABLE UP
85	-----	SW-1A-217-4	LEFT UP/DOWN BANK TARGET
86	-----	SW-1A-217-4	RIGHT UP/DOWN BANK TARGET
87	-----	5647-12693-69	FRANK HIT
88	NOT USED	NOT USED	NOT USED

*NOT SHOWN. **SCORE SWITCHES HAVE DIODES ATTACHED.

Switch Locations

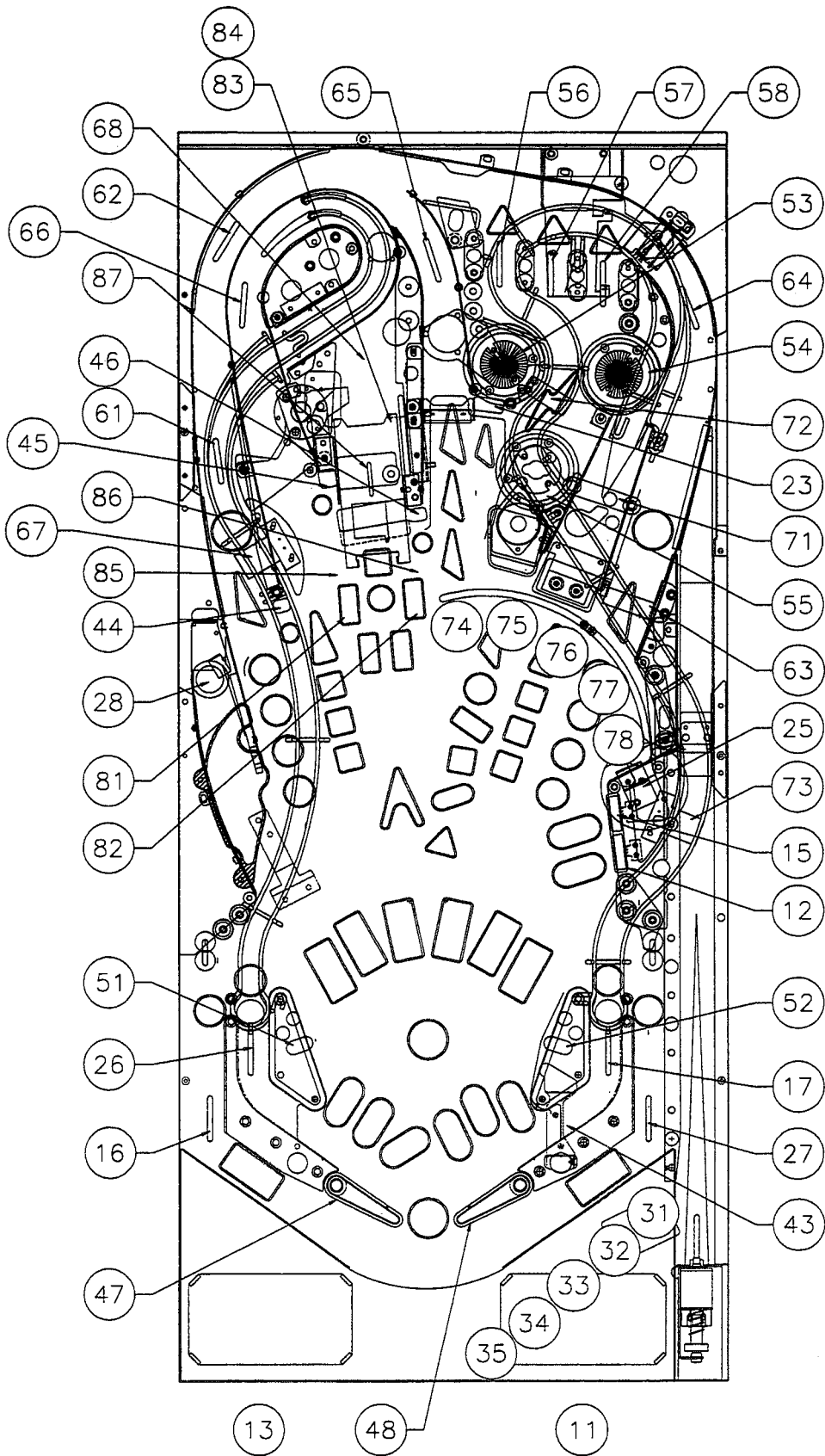

SWITCH MATRIX

White  Green

DEDICATED GROUNDED SWITCHES	Column		1	2	3	4	5	6	7	8	FLIPPER GROUNDED SWITCHES
	Row		Green-Brown J206-1 U20-18	Green-Red J206-2 U20-17	Green-Orange J206-3 U20-16	Green-White J206-4 U20-15	Green-Black J206-5 U20-14	Green-Blue J206-6 U20-13	Green-Violet J206-7 U20-12	Green-Gray J206-9 U20-11	
Orange-Brown J205-1 LEFT COIN CHUTE U17-5 D1	1 White-Brown J208-1 U18-11		LAUNCH BUTTON 11	SLAM TILT 21	TROUGH EJECT 31	NOT USED 41	LEFT SLINGSHOT 51	LEFT LOOP LOW 61	RIGHT RAMP ENTER 71	UP/DOWN BANK UP 81	BLACK-GREEN J208-13 LOWER RIGHT FLIPPER E.O.S. F1
Orange-Red J205-2 CENTER COIN CHUTE U17-7 D2	2 White-Red J208-2 U18-9		DRACULA STANDUP TOP 12	COIN DOOR CLOSED 22	TROUGH BALL 1 32	LEFT FLIPPER OPTO 42	RIGHT SLINGSHOT 52	LEFT LOOP HIGH 62	RIGHT RAMP EXIT 72	UP/DOWN BANK DOWN 82	BLUE-VIOLET J212-12 LOWER RIGHT FLIPPER OPTO F2
Orange-Black J205-3 RIGHT COIN CHUTE U17-11 D3	3 White-Orange J208-3 U18-5		START BUTTON 13	TOMB TREASURE 23	TROUGH BALL 2 33	RIGHT FLIPPER OPTO 43	LEFT JET BUMPER 53	RIGHT LOOP LOW 63	RIGHT RAMP LOCK 73	FRANK TABLE DOWN 83	BLACK-BLUE J208-12 LOWER LEFT FLIPPER E.O.S. F3
Orange-Yellow J205-4 4TH COIN CHUTE U17-9 D4	4 White-Yellow J208-4 U18-7		PLUMB BOB TILT 14	ALWAYS CLOSED 24	TROUGH BALL 3 34	LEFT BLUE TARGET 44	RIGHT JET BUMPER 54	RIGHT LOOP HIGH 64	DRACULA POSITION 5 74	FRANK TABLE UP 84	BLUE-GRAY J212-11 LOWER LEFT FLIPPER OPTO F4
Orange-Green J205-6 U16-9 Normal Test Function Function Srv Crdts Escape D5	5 White-Green J208-5 U19-11		DRACULA STANDUP BOTTOM 15	DRACULA TARGET 25	TROUGH BALL 4 35	CENTER BLUE TARGET 45	BOTTOM JET BUMPER 55	CENTER LOOP 65	DRACULA POSITION 4 75	LEFT UP/DOWN BANK TARGET 85	BLACK-VIOLET J208-11 UPPER RIGHT FLIPPER E.O.S. F5
Orange-Blue J205-7 U16-11 Normal Test Function Function Volume Dn Down D6	6 White-Blue J208-7 U19-9		LEFT OUTLANE 16	LEFT RETURN LANE 26	RIGHT POPPER 36	RIGHT BLUE TARGET 46	LEFT TOP LANE 56	LEFT RAMP ENTER 66	DRACULA POSITION 3 76	RIGHT UP/DOWN BANK TARGET 86	BLACK-YELLOW J212-10 UPPER RIGHT FLIPPER OPTO F6
Orange-Violet J205-8 U16-7 Normal Test Function Function Volume Up Up D7	7 White-Violet J208-8 U19-5		RIGHT RETURN LANE 17	RIGHT OUTLANE 27	NOT USED 37	LEFT FLIPPER PROXIMITY SENSOR 47	CENTER TOP LANE 57	LEFT RAMP EXIT 67	DRACULA POSITION 2 77	FRANK HIT 87	BLACK-GRAY J208-10 CENTER SPINNER. F7
Orange-Gray J205-9 U16-5 Normal Test Function Function Begin Test Enter D8	8 White-Gray J208-9 U19-7		SHOOTER LANE 18	LEFT EJECT 28	NOT USED 38	RIGHT FLIPPER PROXIMITY SENSOR 48	RIGHT TOP LANE 58	CENTER RAMP ENTER 68	DRACULA POSITION 1 78	NOT USED 88	BLACK-BLUE J212-9 UPPER LEFT FLIPPER OPTO F8

J2XX = CPU BOARD

= OPTO, TYPICALLY CLOSED

LAMP MATRIX

Yellow (B+) 0 Red

Column Row	1 Yellow-Brown J121-1 Q96	2 Yellow-Red J121-2 Q100	3 Yellow-Orange J121-3 Q95	4 Yellow-Black J121-4 Q99	5 Yellow-Green J121-5 Q94	6 Yellow-Blue J121-6 Q98	7 Yellow-Violet J121-7 Q93	8 Yellow-Gray J121-9 Q97
1 Red-Brown J125-1 Q104	MONSTER MOSH PIT 11	RIGHT RAMP ARROW 21	QUARTER MOOM (2) 31	LEFT RETURN 41	GUITAR 51	CREATURE 61	LEFT FRANK ARM 71	MUCK 81
2 Red-Black J125-2 Q108	HALF MOON (2) 12	ROCK C.D. 22	LEFT BLUE TARGET 32	LEFT OUTLANE 42	DRUMS 52	BRIDE 62	LEFT FRANK LEG 72	SEAWEED 82
3 Red-Orange J125-4 Q103	FRANK ARROW 13	RIGHT RETURN 23	TOMB TREASURE 33	THREE - QUARTERS MOON (2) 43	BASS GUITAR 53	FRANKEN-STEIN 63	FRANK TORSO 73	ALGAE 83
4 Red-Yellow J125-5 Q107	DRAC - ATTTACK 14	FULL MOON FEVER (2) 24	DRACULA STANDUP TOP 34	RIGHT BLUE TARGET 44	KEYBOARD 54	MUMMY 64	FRANK HEAD 74	POND SCUM 84
5 Red-Green J125-6 Q102	EXTRA BALL 15	RIGHT GARGLE 25	RIGHT TOP LANE 35	LEFT RAMP ARROW 45	MICRO-PHONE 55	WOLFMAN 65	RIGHT FRANK LEG 75	CENTER LOOP ARROW 2 85
6 Red-Blue J125-7 Q106	MONSTERS OF ROCK 16	RIGHT WARM UP 26	CENTER TOP LANE 36	LEFT PRIMP 46	SAXOPHONE 56	DRACULA 66	RIGHT FRANK ARM 76	CENTER LOOP ARROW 1 86
7 Red-Violet J125-8 Q101	MONSTER BASH 17	RIGHT PRIMP 27	LEFT TOP LANE 37	LEFT WARM UP 47	CENTER LOOP ARROW 3 57	RIGHT OUTLANE 67	LEFT LOOP ARROW 77	LAUNCH BUTTON 87
8 Red-Gray J125-9 Q105	MUMMY MAYHEM 18	RIGHT LOOP ARROW 28	DRACULA STANDUP BOTTOM 38	LEFT GARGOYLE 48	CENTER BLUE TARGET 58	SHOOT AGAIN 68	NOT USED 78	START BUTTON 88

J1XX = Power Driver Board

SOLENOID/FLASHER TABLE

Sol. No.	Function	Solenoid Type	Voltage Connections			Drive Xistor	Drive Connections			Drive Wire Color	Solenoid Part Number	
			Playfield	Insert	Cabinet		Playfield	Insert	Cabinet		Flashlamp Type	Playfield
01	AUTO PLUNGER	High Power	J133-2			Q72	J116-1			VIO-BRN	AE-24-900	
02	BRIDE POST	High Power	J133-2			Q68	J116-2			VIO-RED	AE-26-1500	
03	MUMMY COFFIN	High Power	J133-2			Q71	J116-4			VIO-ORG	AE-27-1200	
04	NOT USED	High Power				Q67				VIO-YEL		
05	LEFT GATE	High Power	J133-2			Q70	J116-6			VIO-GRN	A-14406	
06	RIGHT GATE	High Power	J133-2			Q66	J116-7			VIO-BLU	A-14406	
07	NOT USED	High Power				Q69				VIO-BLK		
08	RAMP LOCK POST	High Power	J133-2			Q65	J116-9			VIO-GRY	AE-27-1200	
09	TROUGH EJECT	Low Power	J133-3			Q44	J113-1			BRN-BLK	AE-26-1500	
10	LEFT SLINGSHOT	Low Power	J133-3			Q48	J113-3			BRN-RED	AE-26-1200	
11	RIGHT SLINGSHOT	Low Power	J133-3			Q43	J113-4			BRN-ORG	AE-26-1200	
12	LEFT JET BUMPER	Low Power	J133-3			Q47	J113-5			BRN-YEL	AE-26-1200	
13	RIGHT JET BUMPER	Low Power	J133-3			Q42	J113-6			BRN-GRN	AE-26-1200	
14	BOTTOM JET BUMPER	Low Power	J133-3			Q46	J113-7			BRN-BLU	AE-26-1200	
15	LEFT EJECT	Low Power	J133-3			Q41	J113-8			BRN-VIO	AE-30-2000	
16	RIGHT POPPER	Low Power	J133-3			Q45	J113-9			BRN-GRY	AE-25-1000	
17	WOLFMAN FLASHERS	Flasher	J133-6	J134-5		Q28	J111-1	J112-1		BLK-BRN	#906 (2)	#906
18	BRIDE FLASHERS	Flasher	J133-6	J134-5		Q32	J111-2	J112-2		BLK-RED	#89	#906
19	FRANKENSTEIN FLASHERS	Flasher	J133-6	J134-5		Q27	J111-3	J112-3		BLK-ORG	#906 (2)	#906
20	DRACULA COFFIN FLASHERS	Flasher	J133-6	J134-5		Q31	J111-4	J112-5		BLK-YEL	#89	#906
21	CREATURE FLASHERS	Flasher	J133-6			Q26	J111-5			BLU-GRN	#906 (2)	#906
22	JETS/MUMMY FLASHERS	Flasher	J133-6	J134-5		Q30	J111-6	J112-7		BLU-BLK	#906 (2)	#906
23	RIGHT POPPER FLASHER	Flasher	J133-6			Q25	J111-7			BLU-VIO	#906	
24	FRANK ARROW FLASHER	Flasher	J133-6			Q29	J111-8			BLU-GRY	#906	
25	MONSTERS OF ROCK FLSHR	Gen. Purpose	J133-6	J134-5		Q16	J109-1	J108-1		BLU-BRN	#906	#906
26	WOLFMAN LOOP FLASHERS	Gen. Purpose	J133-6			Q15	J109-2			BLU-RED	#906 (2)	
27	FRANKENSTEIN MOTOR	Gen. Purpose	J140-2			Q14	J109-3			BLU-ORG	14-8015	
28	UP/DOWN BANK MOTOR	Gen. Purpose	J140-2			Q13	J109-4			BLU-YEL	14-8015	
Flipper Circuits		Solenoid Type	Playfield Voltage Connection		Drive Xistors	Playfield Drive Connections	Drive Wire Colors		Coil Part No.	Coil Colors		
29	LOWER RIGHT FLIPPER	Power	J119-1 (RED-GRN)		Q90	J120-13	YEL-GRN		FI-11629	BLUE		
30		Hold	J119-1 (RED-GRN)		Q92	J120-11	ORG-GRN					
31	LOWER LEFT FLIPPER	Power	J119-4 (RED-BLU)		Q87	J120-9	YEL-BLU		FL-11629	BLUE		
32		Hold	J119-4 (RED-BLU)		Q89	J120-7	ORG-BLU					
33	NOT USED	Power	J119-6 (RED-VIO)		Q84	J120-6	YEL-VIO					
34		Hold	J119-6 (RED-VIO)		Q86	J120-4	ORG-VIO					
35	NOT USED	Power	J119-8 (RED-GRY)		Q81	J120-3	YEL-GRY					
36		Hold	J119-8 (RED-GRY)		Q83	J120-1	ORG-GRY					
Dracula Motor		Solenoid Type	Playfield Voltage Connection		Drive Gates	Playfield Drive Connections	Drive Wire Colors		Device Part Number			
37	DRACULA MOTOR FORWARD	Low Power	J141-2		U3A, U3B	J110-1	BRN-WHT		14-8034			
38	DRACULA MOTOR BACKWARD	Low Power	J141-2		U3C, U3D	J110-3	ORG-WHT					
General Illumination		Solenoid Type	Voltage Connections			Drive Xistor	Drive Connections			Drive Wire	Bulb Type	
01	BOTTOM PLAYFIELD	G.I.	J105-1			Q5	J105-7			WHT-BRN	#44	
02	TOP RIGHT PLAYFIELD	G.I.	J105-2			Q4	J105-8			WHT-ORG	#44	
03	TOP LEFT PLAYFIELD	G.I.	J105-3			Q3	J105-9			WHT-YEL	#44	
04	*TOP INSERT PANEL	G.I.		J106-5		Q2		J106-10		WHT-GRN		#555
05	*BOTTOM INSERT PANEL	G.I.		J106-6	J104-3	Q1		J106-11	J104-1	WHT-VIO		#555

*These general illumination strings do not brighten and dim, they are always on.

24-6549 = #44 bulb	24-8768 = #555 bulb
24-8704 = #89 bulb	24-8802 = #906 bulb

SECTION THREE

GAME WIRING AND SCHEMATICS

CONNECTOR & COMPONENT IDENTIFICATION

Each plug or jack receives a number that identifies the circuit board and the position on that board that it connects to. J-designations refer to a male connector. P-designations refer to a female connector. For example, J101 designates jack 1 of board 1 (a Power Driver board jack); P206 designates plug 6 of board 2 (a CPU board plug). Identifying the specific pin number of a connector involves a hyphen, which separates the pin number from the plug or jack designation. For example, J101-3 refers to pin 3 of jack 1 on board 1.

Other game components may also have similar numbers to clarify their locations or related circuits. For example, F501 is a fuse on the Audio Video board.

Prefix numbers for WPC circuit boards are listed below.

J1XX - Power Driver board jacks; F1XX - Power Driver board fuses

J2XX - CPU Board (There are no fuses on the CPU board.)

J5XX and J6XX - Audio Video board (AV board) jacks; F5XX and F6XX - Audio Video board fuses

Schematics for standard WPC backbox boards are found in the WPC Schematics Manual. Playfield, cabinet and all other backbox board schematics are found in this section.

SWITCH MATRIX

White Green

DEDICATED GROUNDED SWITCHES	Column	1	2	3	4	5	6	7	8	FLIPPER GROUNDED SWITCHES
	Row	Green-Brown J206-1 U20-18	Green-Red J206-2 U20-17	Green-Orange J206-3 U20-16	Green-White J206-4 U20-15	Green-Black J206-5 U20-14	Green-Blue J206-6 U20-13	Green-Violet J206-7 U20-12	Green-Gray J206-9 U20-11	
Orange-Brown J205-1 LEFT COIN CHUTE U17-5 D1	1 White-Brown J208-1 U18-11	LAUNCH BUTTON 11	SLAM TILT 21	TROUGH EJECT 31	NOT USED 41	LEFT SLINGSHOT 51	LEFT LOOP LOW 61	RIGHT RAMP ENTER 71	UP/DOWN BANK UP 81	BLACK-GREEN J208-13 LOWER RIGHT FLIPPER E.O.S. F1
Orange-Red J205-2 CENTER COIN CHUTE U17-7 D2	2 White-Red J208-2 U18-9	DRACULA STANDUP TOP 12	COIN DOOR CLOSED 22	TROUGH BALL 1 32	LEFT FLIPPER OPTO 42	RIGHT SLINGSHOT 52	LEFT LOOP HIGH 62	RIGHT RAMP EXIT 72	UP/DOWN BANK DOWN 82	BLUE-VIOLET J212-12 LOWER RIGHT FLIPPER OPTO F2
Orange-Black J205-3 RIGHT COIN CHUTE U17-11 D3	3 White-Orange J208-3 U18-5	START BUTTON 13	TOMB TREASURE 23	TROUGH BALL 2 33	RIGHT FLIPPER OPTO 43	LEFT JET BUMPER 53	RIGHT LOOP LOW 63	RIGHT RAMP LOCK 73	FRANK TABLE DOWN 83	BLACK-BLUE J208-12 LOWER LEFT FLIPPER E.O.S. F3
Orange-Yellow J205-4 4TH COIN CHUTE U17-9 D4	4 White-Yellow J208-4 U18-7	PLUMB BOB TILT 14	ALWAYS CLOSED 24	TROUGH BALL 3 34	LEFT BLUE TARGET 44	RIGHT JET BUMPER 54	RIGHT LOOP HIGH 64	DRACULA POSITION 5 74	FRANK TABLE UP 84	BLUE-GRAY J212-11 LOWER LEFT FLIPPER OPTO F4
Orange-Green J205-6 U16-9 Normal Test Function Srv Crdts Escape D5	5 White-Green J208-5 U19-11	DRACULA STANDUP BOTTOM 15	DRACULA TARGET 25	TROUGH BALL 4 35	CENTER BLUE TARGET 45	BOTTOM JET BUMPER 55	CENTER LOOP 65	DRACULA POSITION 4 75	LEFT UP/DOWN BANK TARGET 85	BLACK-VIOLET J208-11 UPPER RIGHT FLIPPER E.O.S. F5
Orange-Blue J205-7 U16-11 Normal Test Function Volume Dn Function Down D6	6 White-Blue J208-7 U19-9	LEFT OUTLANE 16	LEFT RETURN LANE 26	RIGHT POPPER 36	RIGHT BLUE TARGET 46	LEFT TOP LANE 56	LEFT RAMP ENTER 66	DRACULA POSITION 3 76	RIGHT UP/DOWN BANK TARGET 86	BLACK-YELLOW J212-10 UPPER RIGHT FLIPPER OPTO F6
Orange-Violet J205-8 U16-7 Normal Test Function Volume Up Function Up D7	7 White-Violet J208-8 U19-5	RIGHT RETURN LANE 17	RIGHT OUTLANE 27	NOT USED 37	LEFT FLIPPER PROXIMITY SENSOR 47	CENTER TOP LANE 57	LEFT RAMP EXIT 67	DRACULA POSITION 2 77	FRANK HIT 87	BLACK-GRAY J208-10 CENTER SPINNER. F7
Orange-Gray J205-9 U16-5 Normal Test Function Begin Test Function Enter D8	8 White-Gray J208-9 U19-7	SHOOTER LANE 18	LEFT EJECT 28	NOT USED 38	RIGHT FLIPPER PROXIMITY SENSOR 48	RIGHT TOP LANE 58	CENTER RAMP ENTER 68	DRACULA POSITION 1 78	NOT USED 88	BLACK-BLUE J212-9 UPPER LEFT FLIPPER OPTO F8

J2XX = CPU BOARD

= OPTO, TYPICALLY CLOSED

SWITCH MATRIX CIRCUIT

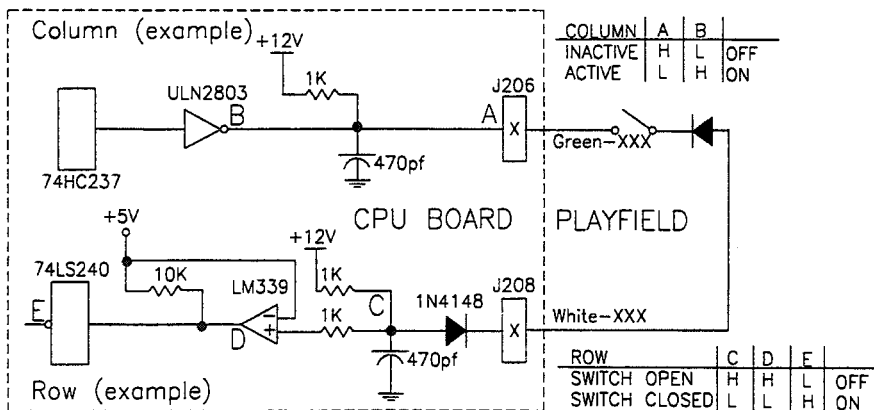

The microprocessor is constantly strobing the column side of the switch. When point "A" on the column circuit toggles low, the column side is active. When a switch closes, the row side of the circuit activates. The "+" input to the LM339 drops below +5V, therefore, its output is low. Corresponding row and column switches must be low at the same time for the switch to be considered closed by the microprocessor. When the switch opens, the "+" input to the LM339 is above +5V, its output is high and the row is inactive.

DEDICATED SWITCHES

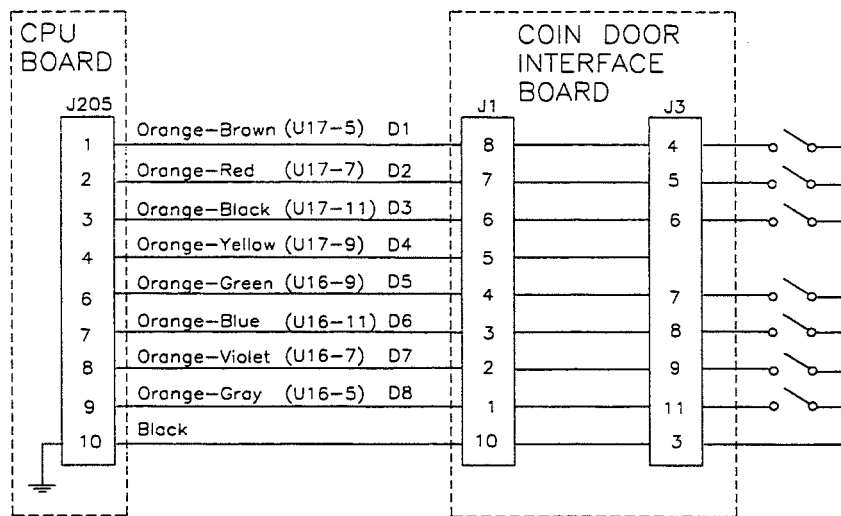

Coin Acceptor Switches

- D1 - Left Coin Chute
- D2 - Center Coin Chute
- D3 - Right Coin Chute
- D4 - Fourth Coin Chute

Control Switches

- D5 - Normal Function, Service Credits; Test Function, Escape
- D6 - Normal Function, Volume Down; Test Function, Down
- D7 - Normal Function, Volume Up; Test Function, Up
- D8 - Normal Function, Begin Test; Test Function, Enter

DEDICATED SWITCH CIRCUIT

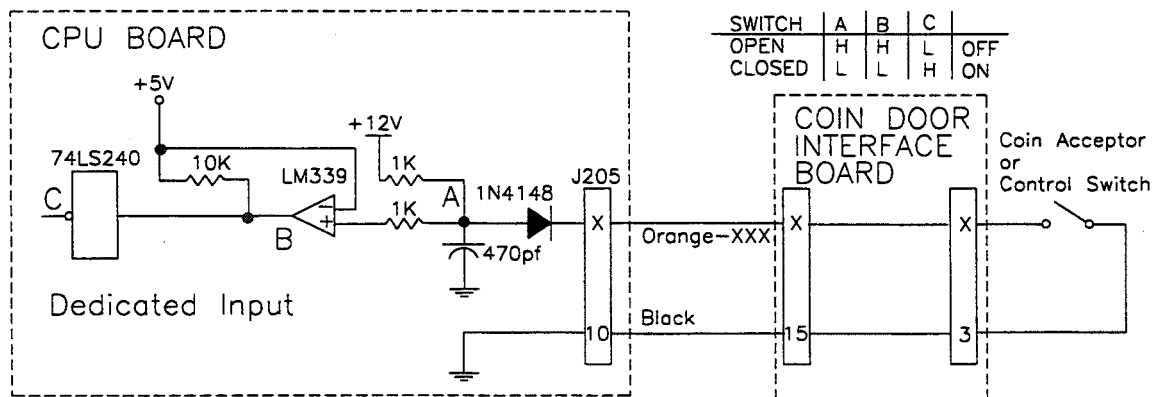

The dedicated switches operate similar in the matrix, except that instead of a column circuit there is a direct tie to ground. Therefore, the column side is constantly active (low).

When a switch closes, the row side (dedicated input) of the circuit activates. The "+" input to the LM339 drops below +5V, therefore the output is low. Since the row circuit (dedicated input) is tied directly to ground through the switch, the switch is considered closed by the microprocessor. When the switch opens, the "+" input to the LM339 is above +5V, its output is high and the row is inactive.

LAMP MATRIX

Yellow (B+) 1

Red

Column \ Row	1 Yellow-Brown J121-1 Q96	2 Yellow-Red J121-2 Q100	3 Yellow-Orange J121-3 Q95	4 Yellow-Black J121-4 Q99	5 Yellow-Green J121-5 Q94	6 Yellow-Blue J121-6 Q98	7 Yellow-Violet J121-7 Q93	8 Yellow-Gray J121-9 Q97
1 Red-Brown J125-1 Q104	MONSTER MOSH PIT 11	RIGHT RAMP ARROW 21	QUARTER MOOM (2) 31	LEFT RETURN 41	GUITAR 51	CREATURE 61	LEFT FRANK ARM 71	MUCK 81
2 Red-Black J125-2 Q108	HALF MOON (2) 12	ROCK C.D. 22	LEFT BLUE TARGET 32	LEFT OUTLANE 42	DRUMS 52	BRIDE 62	LEFT FRANK LEG 72	SEAWEED 82
3 Red-Orange J125-4 Q103	FRANK ARROW 13	RIGHT RETURN 23	TOMB TREASURE 33	THREE - QUARTERS MOON (2) 43	BASS GUITAR 53	FRANKEN-STEIN 63	FRANK TORSO 73	ALGAE 83
4 Red-Yellow J125-5 Q107	DRAC - ATTACK 14	FULL MOON FEVER (2) 24	DRACULA STANDUP TOP 34	RIGHT BLUE TARGET 44	KEYBOARD 54	MUMMY 64	FRANK HEAD 74	POND SCUM 84
5 Red-Green J125-6 Q102	EXTRA BALL 15	RIGHT GARGLE 25	RIGHT TOP LANE 35	LEFT RAMP ARROW 45	MICRO-PHONE 55	WOLFMAN 65	RIGHT FRANK LEG 75	CENTER LOOP ARROW 2 85
6 Red-Blue J125-7 Q106	MONSTERS OF ROCK 16	RIGHT WARM UP 26	CENTER TOP LANE 36	LEFT PRIMP 46	SAXOPHONE 56	DRACULA 66	RIGHT FRANK ARM 76	CENTER LOOP ARROW 1 86
7 Red-Violet J125-8 Q101	MONSTER BASH 17	RIGHT PRIMP 27	LEFT TOP LANE 37	LEFT WARM UP 47	CENTER LOOP ARROW 3 57	RIGHT OUTLANE 67	LEFT LOOP ARROW 77	LAUNCH BUTTON 87
8 Red-Gray J125-9 Q105	MUMMY MAYHEM 18	RIGHT LOOP ARROW 28	DRACULA STANDUP BOTTOM 38	LEFT GARGOYLE 48	CENTER BLUE TARGET 58	SHOOT AGAIN 68	NOT USED 78	START BUTTON 88

J1XX = Power Driver Board

LAMP MATRIX CIRCUIT

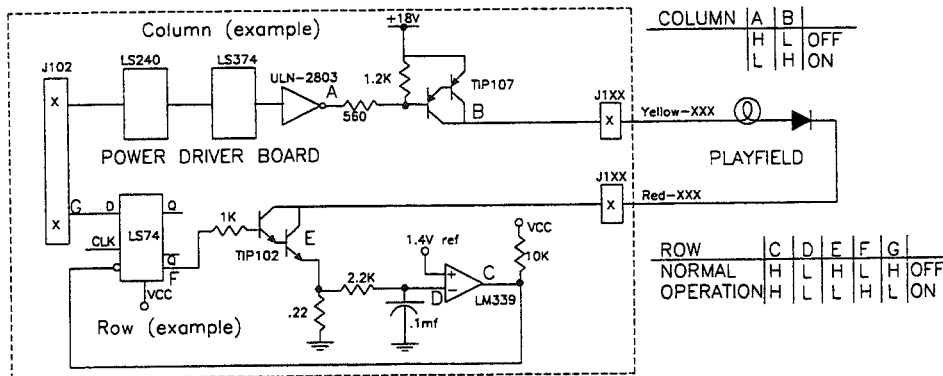

The microprocessor sends a signal to the column circuit causing the output of the UNL-2803 to toggle. When point "A" drops low, the TIP107 transistor conducts and point "B" changes to a high state. At the same time, the microprocessor drives the input of the 74LS74 low, causing a high at output "F". A high state at the base of the TIP102 causes the transistor to conduct, bringing the row circuit to ground and turning the lamp on. The microprocessor changes the input of the 74LS74 to a high state to turn the lamp off. In overcurrent conditions, the lamp is shut off through the comparator. If the voltage at the negative input of the LM339 rises above 1.4V, the output changes to a low, which is fed back to the 74LS74 and shuts the circuit off.

SOLENOID/FLASHER TABLE

Sol. No.	Function	Solenoid Type	Voltage Connections			Drive Xistor	Drive Connections			Drive Wire Color	Solenoid Part Number	
			Playfield	Insert	Cabinet		Playfield	Insert	Cabinet		Flashlamp Type	Playfield
01	AUTO PLUNGER	High Power	J133-2			Q72	J116-1			VIO-BRN	AE-24-900	
02	BRIDE POST	High Power	J133-2			Q68	J116-2			VIO-RED	AE-26-1500	
03	MUMMY COFFIN	High Power	J133-2			Q71	J116-4			VIO-ORG	AE-27-1200	
04	NOT USED	High Power				Q67				VIO-YEL		
05	LEFT GATE	High Power	J133-2			Q70	J116-6			VIO-GRN	A-14406	
06	RIGHT GATE	High Power	J133-2			Q66	J116-7			VIO-BLU	A-14406	
07	NOT USED	High Power				Q69				VIO-BLK		
08	RAMP LOCK POST	High Power	J133-2			Q65	J116-9			VIO-GRY	AE-27-1200	
09	TROUGH EJECT	Low Power	J133-3			Q44	J113-1			BRN-BLK	AE-26-1500	
10	LEFT SLINGSHOT	Low Power	J133-3			Q48	J113-3			BRN-RED	AE-26-1200	
11	RIGHT SLINGSHOT	Low Power	J133-3			Q43	J113-4			BRN-ORG	AE-26-1200	
12	LEFT JET BUMPER	Low Power	J133-3			Q47	J113-5			BRN-YEL	AE-26-1200	
13	RIGHT JET BUMPER	Low Power	J133-3			Q42	J113-6			BRN-GRN	AE-26-1200	
14	BOTTOM JET BUMPER	Low Power	J133-3			Q46	J113-7			BRN-BLU	AE-26-1200	
15	LEFT EJECT	Low Power	J133-3			Q41	J113-8			BRN-VIO	AE-30-2000	
16	RIGHT POPPER	Low Power	J133-3			Q45	J113-9			BRN-GRY	AE-25-1000	
17	WOLFMAN FLASHERS	Flasher	J133-6	J134-5		Q28	J111-1	J112-1		BLK-RED	#906 (2)	#906
18	BRIDE FLASHERS	Flasher	J133-6	J134-5		Q32	J111-2	J112-2		BLK-RED	#89	#906
19	FRANKENSTEIN FLASHERS	Flasher	J133-6	J134-5		Q27	J111-3	J112-3		BLK-ORG	#906 (2)	#906
20	DRACULA COFFIN FLASHERS	Flasher	J133-6	J134-5		Q31	J111-4	J112-5		BLK-YEL	#89	#906
21	CREATURE FLASHERS	Flasher	J133-6			Q26	J111-5			BLU-GRN	#906 (2)	
22	JETS/MUMMY FLASHERS	Flasher	J133-6	J134-5		Q30	J111-6	J112-7		BLU-BLK	#906 (2)	#906
23	RIGHT POPPER FLASHER	Flasher	J133-6			Q25	J111-7			BLU-VIO	#906	
24	FRANK ARROW FLASHER	Flasher	J133-6			Q29	J111-8			BLU-GRY	#906	
25	MONSTERS OF ROCK FLASHER	Gen. Purpose	J133-6	J134-5		Q16	J109-1	J108-1		BLU-BRN	#906	#906
26	WOLFMAN LOOP FLASHERS	Gen. Purpose	J133-6			Q15	J109-2			BLU-RED	#906 (2)	
27	FRANKENSTEIN MOTOR	Gen. Purpose	J140-2			Q14	J109-3			BLU-ORG	14-8015	
28	UP/DOWN BANK MOTOR	Gen. Purpose	J140-2			Q13	J109-4			BLU-YEL	14-8015	
Flipper Circuits		Solenoid Type	Playfield Voltage Connection		Drive Xistors	Hold	Playfield Drive Connections		Drive Wire Colors		Coil Part No.	Coil Colors
29	LOWER RIGHT FLIPPER	Power	J119-1 (RED-GRN)		Q90		J120-13		YEL-GRN		FI-11629	BLUE
30		Hold	J119-1 (RED-GRN)			Q92	J120-11		ORG-GRN			
31	LOWER LEFT FLIPPER	Power	J119-4 (RED-BLU)		Q87		J120-9		YEL-BLU		FL-11629	BLUE
32		Hold	J119-4 (RED-BLU)			Q89	J120-7		ORG-BLU			
33	NOT USED	Power	J119-6 (RED-VIO)		Q84		J120-6		YEL-VIO			
34		Hold	J119-6 (RED-VIO)			Q86	J120-4		ORG-VIO			
35	NOT USED	Power	J119-8 (RED-GRY)		Q81		J120-3		YEL-GRY			
36		Hold	J119-8 (RED-GRY)			Q83	J120-1		ORG-GRY			
Dracula Motor		Solenoid Type	Playfield Voltage Connection		Drive Gates		Playfield Drive Connections		Drive Wire Colors		Device Part Number	
37	DRACULA MOTOR FORWARD	Low Power	J141-2		U3A, U3B		J110-1		BRN-WHT		14-8034	
38	DRACULA MOTOR BACKWARD	Low Power	J141-2		U3C, U3D		J110-3		ORG-WHT			
General Illumination		Solenoid Type	Voltage Connections			Drive Xistor	Drive Connections			Drive Wire	Bulb Type	
01	BOTTOM PLAYFIELD	G.I.	J105-1			Q5	J105-7			WHT-BRN	#44	
02	TOP RIGHT PLAYFIELD	G.I.	J105-2			Q4	J105-8			WHT-ORG	#44	
03	TOP LEFT PLAYFIELD	G.I.	J105-3			Q3	J105-9			WHT-YEL	#44	
04	*TOP INSERT PANEL	G.I.		J106-5		Q2		J106-10		WHT-GRN		#555
05	*BOTTOM INSERT PANEL	G.I.		J106-6	J104-3	Q1		J106-11	J104-1	WHT-VIO		#555

*These general illumination strings do not brighten and dim, they are always on.

24-6549 = #44 bulb	24-8768 = #555 bulb
24-8704 = #89 bulb	24-8802 = #906 bulb

SOLENOID WIRING

COILS

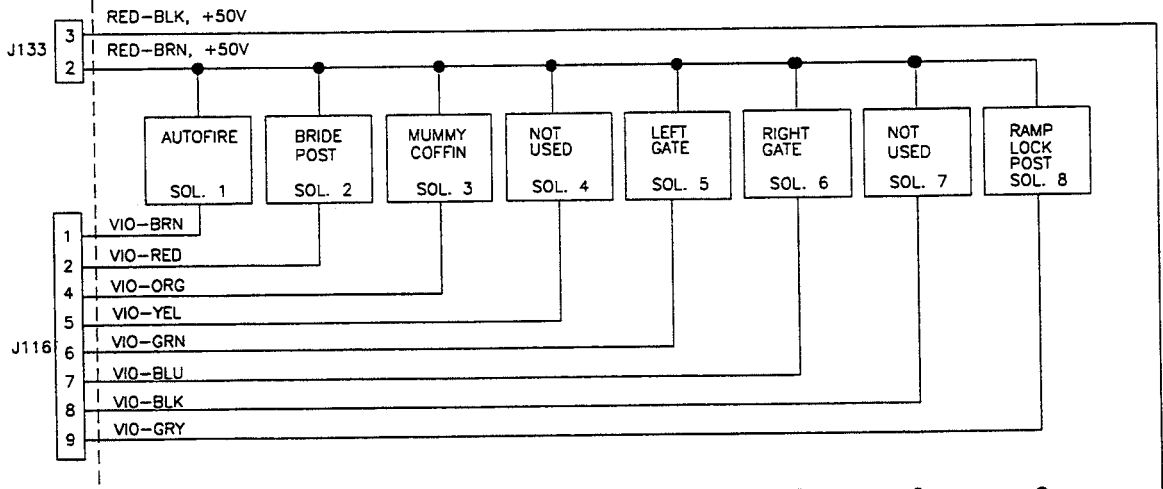

POWER DRIVER BOARD

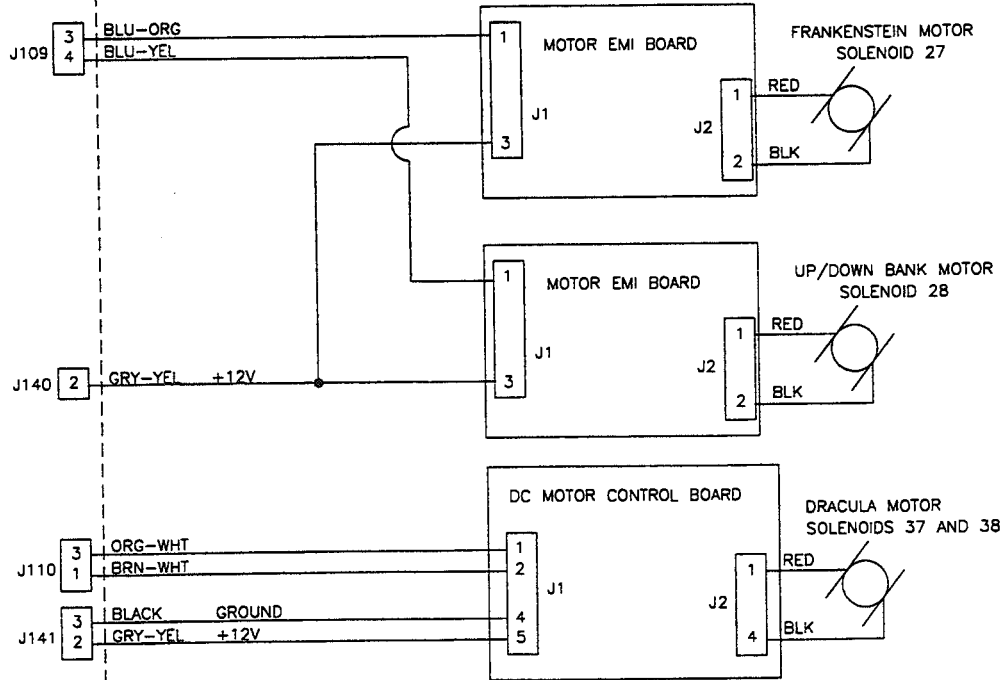
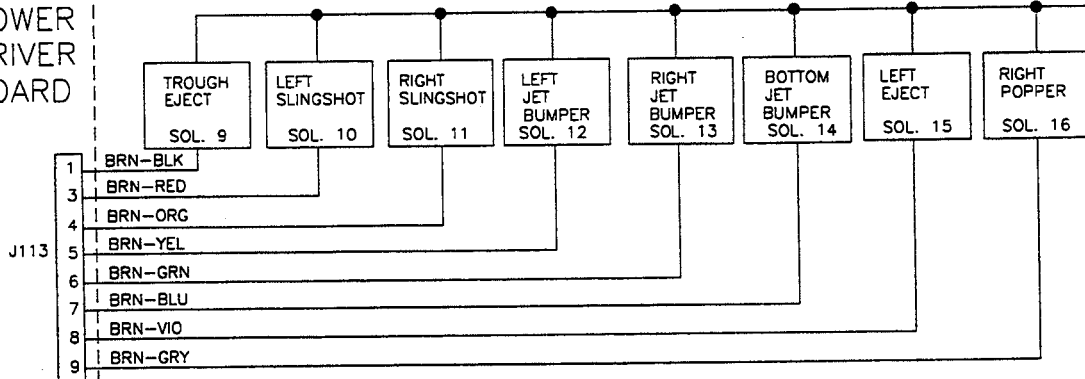

FLASHLAMPS

PLAYFIELD

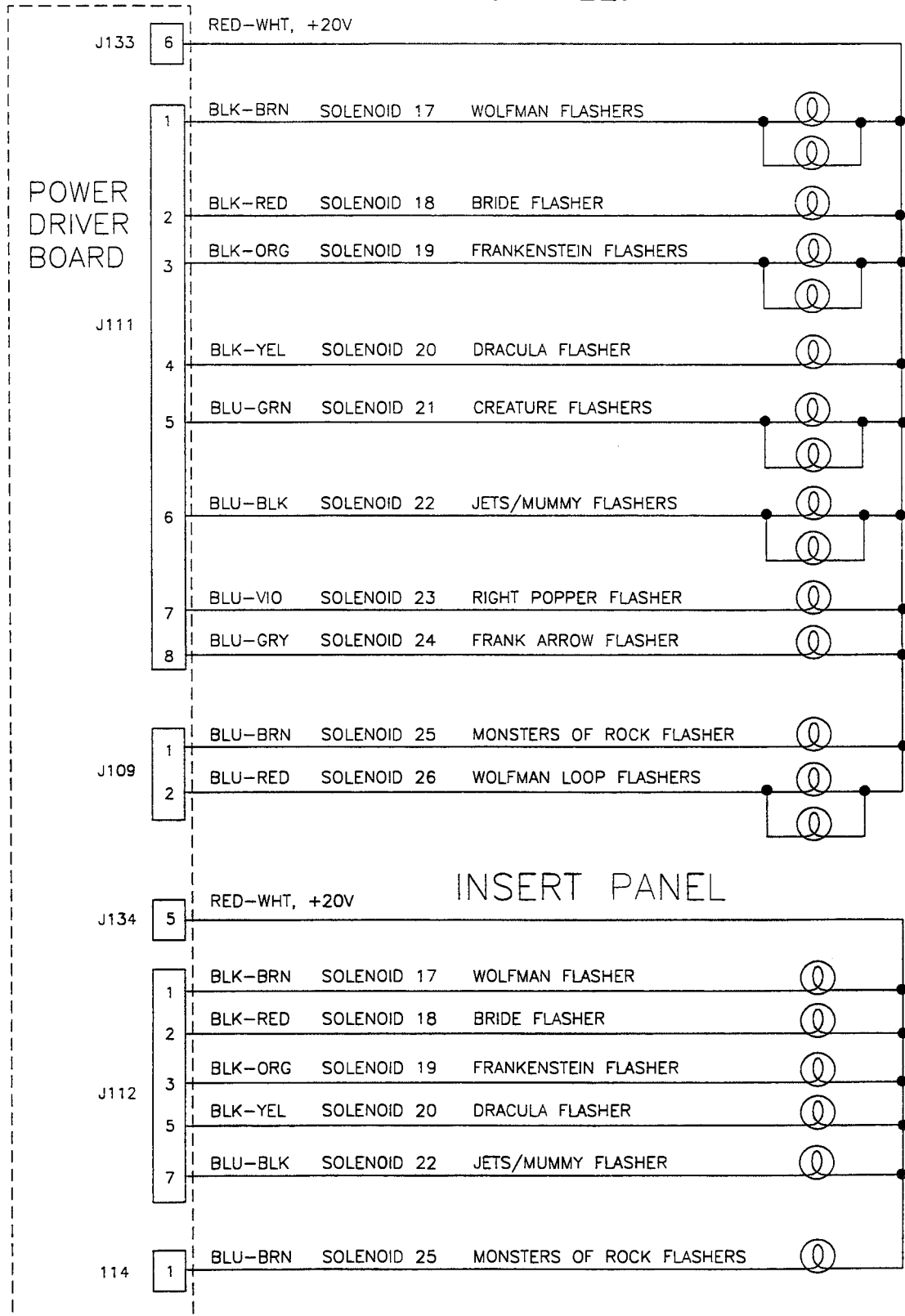

HIGH POWER SOLENOID CIRCUIT

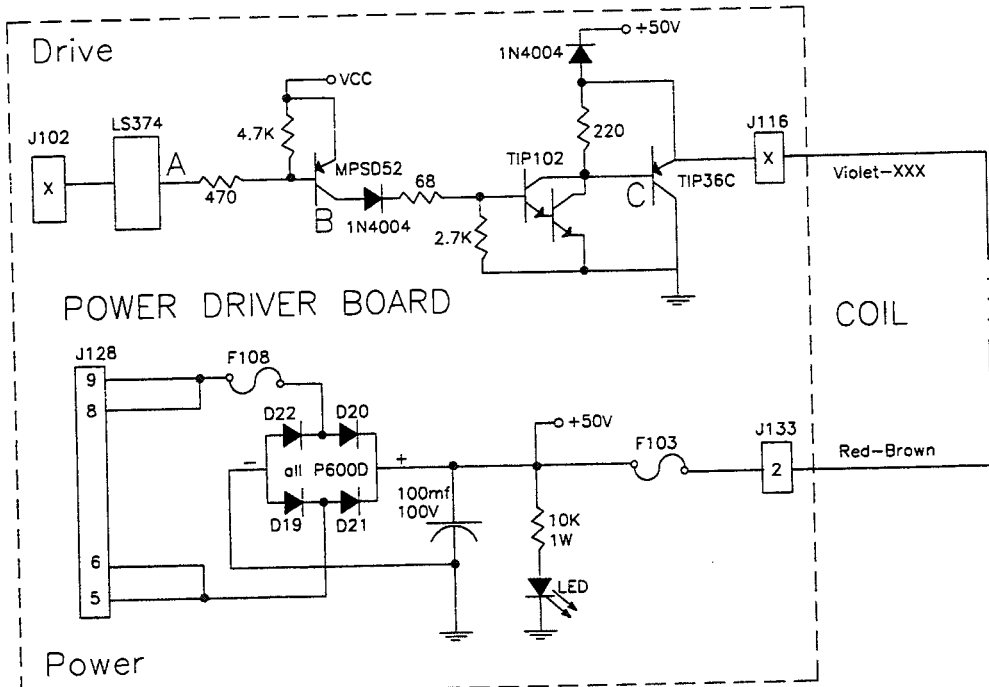

The microprocessor toggles the output of the 74LS374. When point "A" is low, point "B", the collector of the 2N5401 transistor, is high. A high at point "B" causes point "C", the collector of the TIP102 transistor and point "D", the emitter of the TIP36C transistor, to drop low. When point "D" is low, the coil is grounded through the transistor and turns on. The coil shuts off when point "A" toggles high.

LOW POWER SOLENOID CIRCUIT

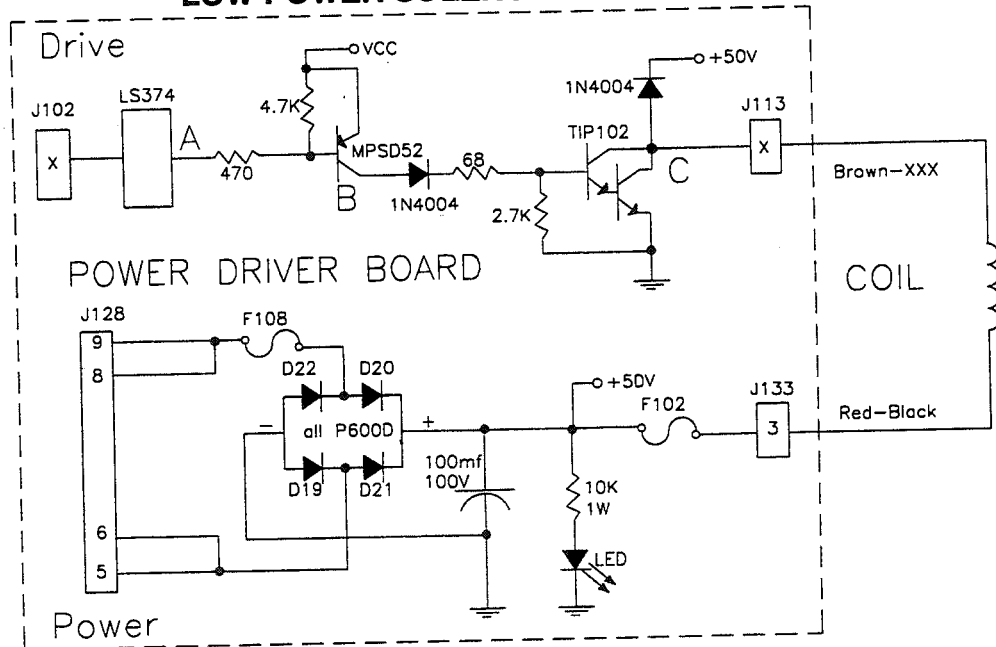

The microprocessor toggles the output of the 74LS374. When point "A" is low, point "B", the collector of the 2N5401 transistor, is high. A high at point "B" turns on the TIP102 transistor and causes point "C" to drop low. When point "C" is low the coil is grounded through the transistor and turns on. The coil shuts off when point "A" toggles high.

SPECIAL (GENERAL PURPOSE) SOLENOID CIRCUIT

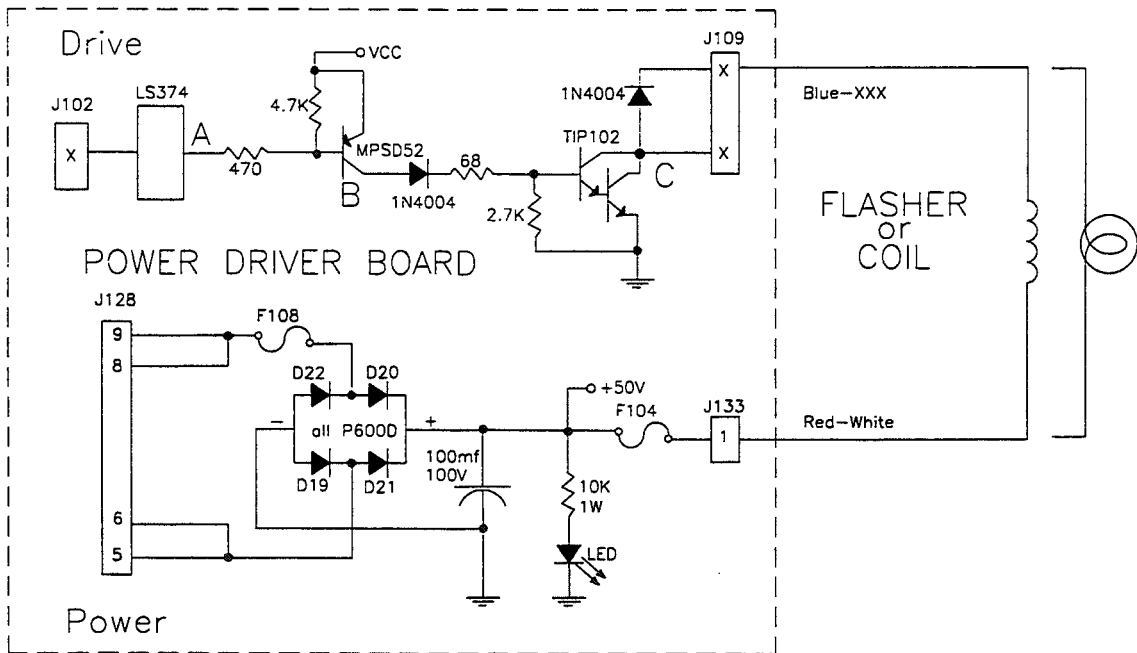

The microprocessor toggles the output of the 74LS374. When point "A" is low, point "B" the collector of the 2N5401 transistor, is high. A high at point "B" causes a low at point "C". When point "C" is low, the coil/flashlamp is grounded through the transistor and turns on. When point "A" toggles high the coil/flashlamp turns off.

* Tieback diode is not used for flashlamp circuit.

FLASHLAMP CIRCUIT

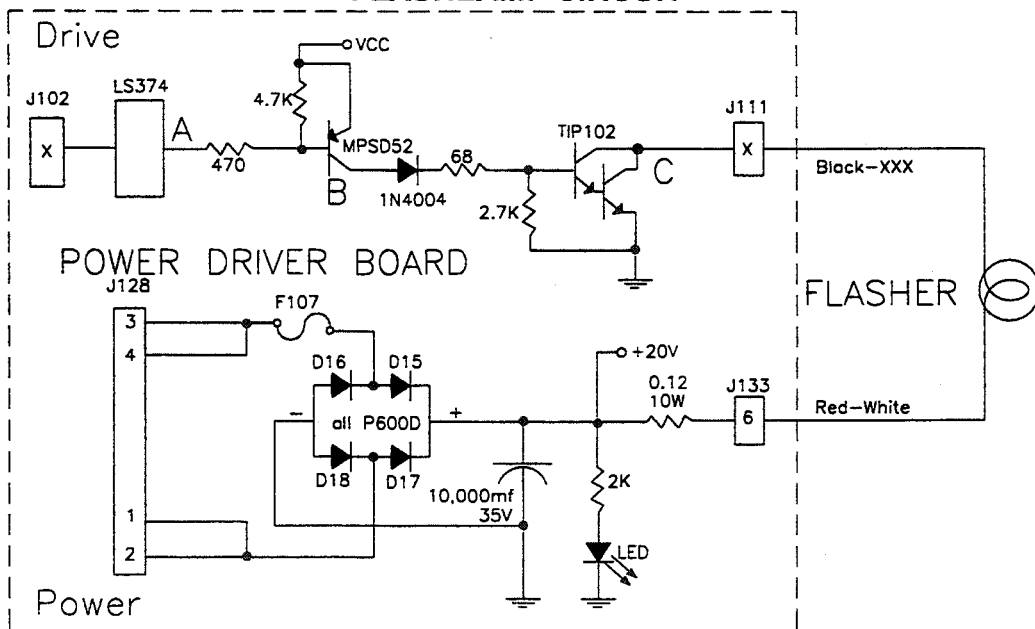

The microprocessor toggles the output of the 74LS374. When point "A" is low, point "B" the collector of the 2N5401 transistor, is high. Once point "B" is high, point "C" the collector of the TIP102 transistor is low. When point "C" is low, the flashlamp is grounded through the transistor and turns on. When point "A" toggles high, the current shuts off.

GENERAL ILLUMINATION CIRCUIT

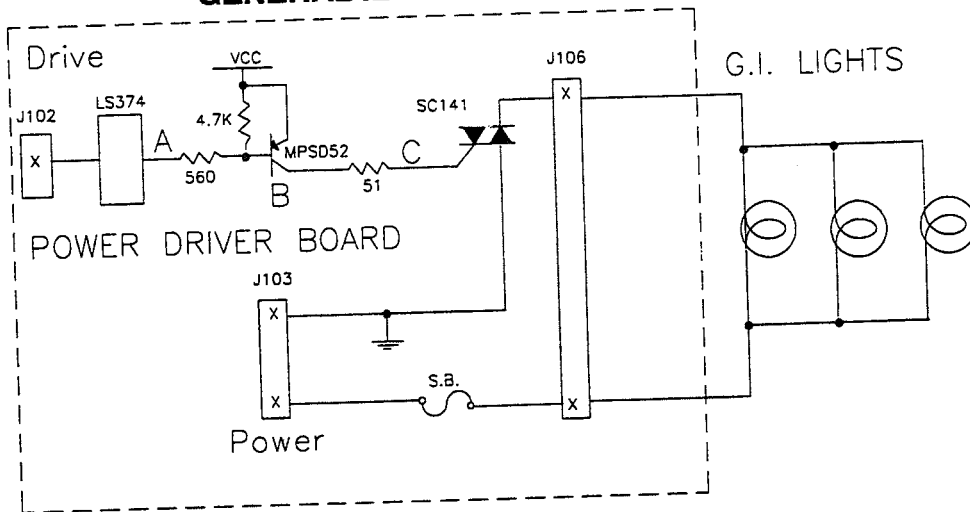

Figure #1

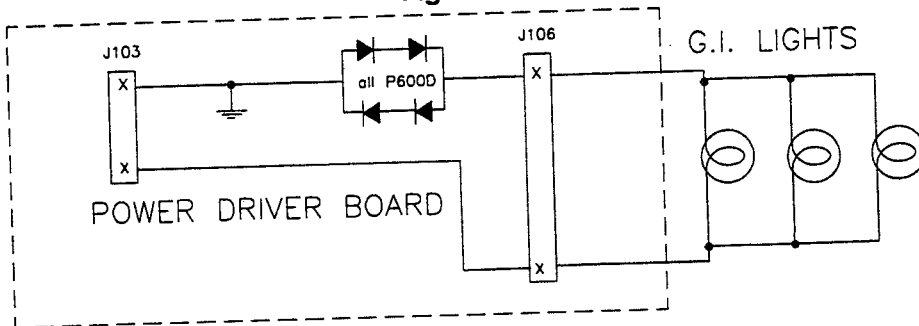
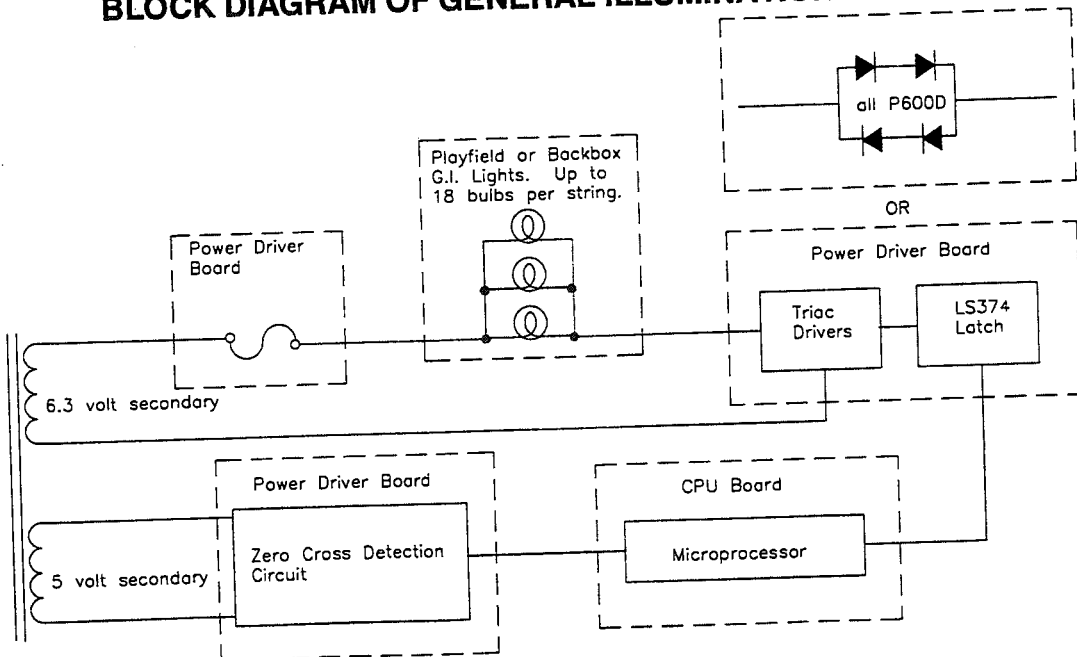

Figure #2

There are five general illumination strings; three like figure #1 and two like figure #2. When point "A" toggles low, points, "B" and "C" are high. This turns on the triac and the desired general illumination string of lights.

BLOCK DIAGRAM OF GENERAL ILLUMINATION CIRCUIT



FLIPPER CIRCUIT DIAGRAM

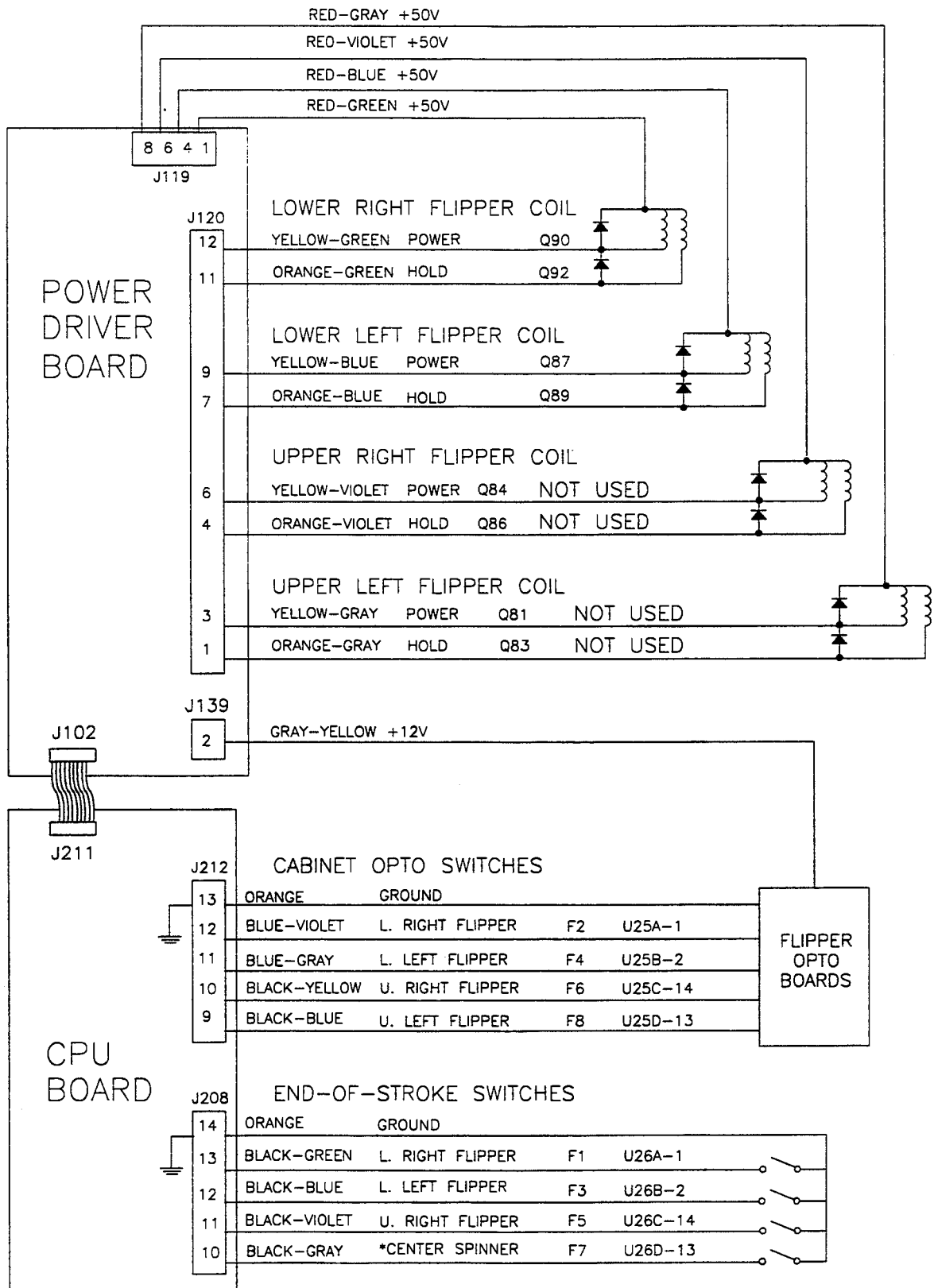

*In this game, flipper switch #F7 is used for the CENTER SPINNER.

FLIPPER COIL CIRCUITS

LEFT FLIPPER CIRCUIT

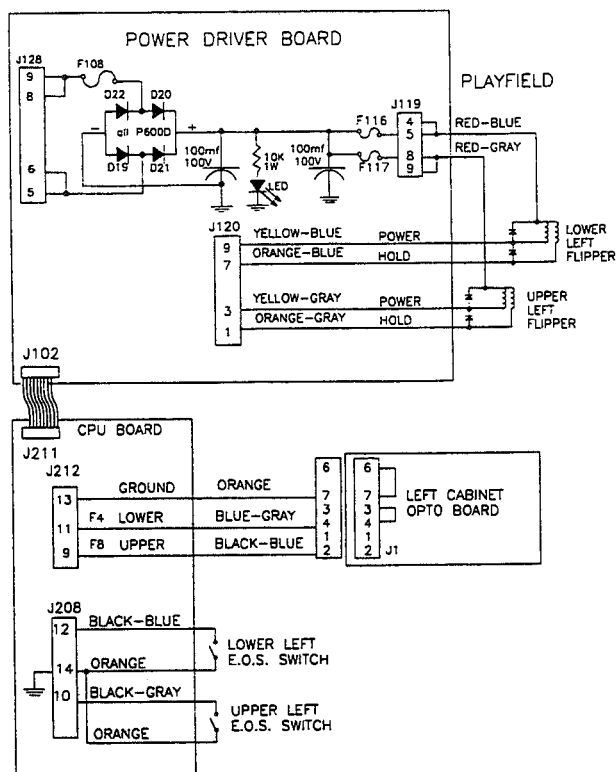

RIGHT FLIPPER CIRCUIT

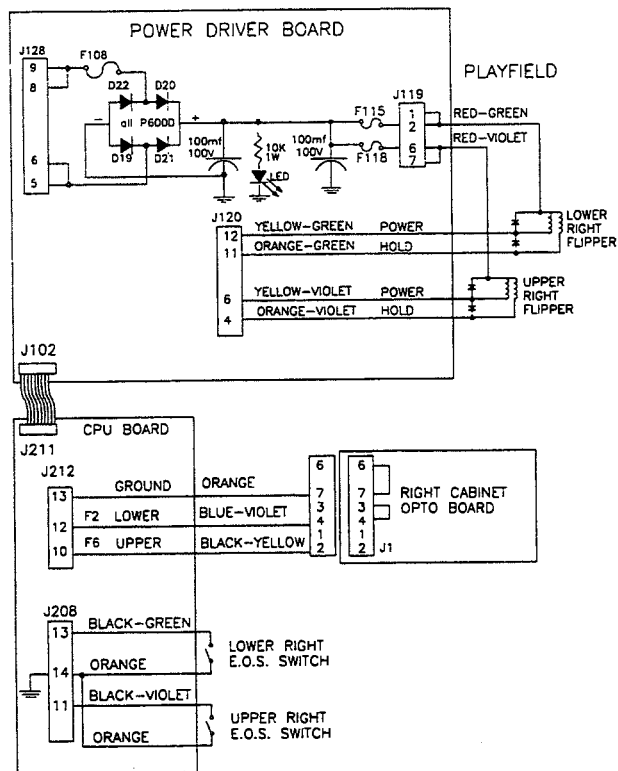

FLIPPER END-OF-STROKE SWITCH CIRCUIT

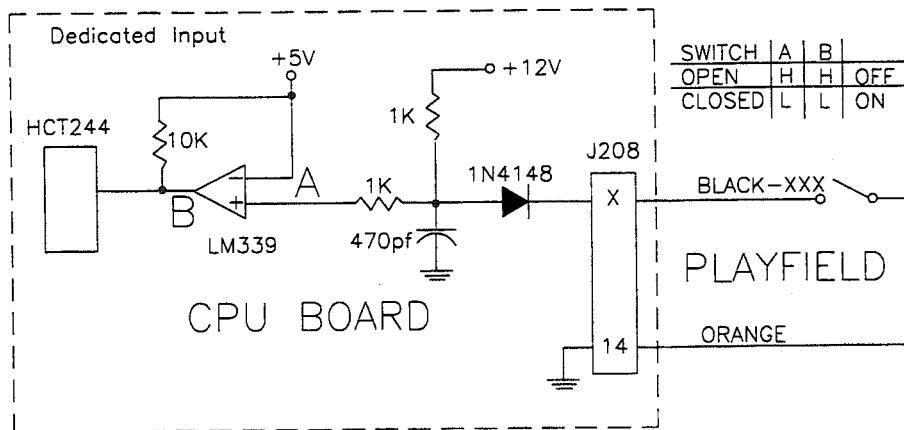

The flipper E.O.S. circuits operate similar to the dedicated switch circuit. The circuits are active low and tied to ground through the switch.

When a switch closes, the row side, (dedicated input), of the circuit activates. The "+" input of the LM339 drops below +5V therefore its output is low. Since the row (dedicated input), circuit is tied directly to ground through the switch, the switch is considered closed by the microprocessor. When the switch opens, the "+" input to the LM339 is above +5V, its output is high and the row (dedicated input) is inactive.

FLIPPER CABINET SWITCH CIRCUITS

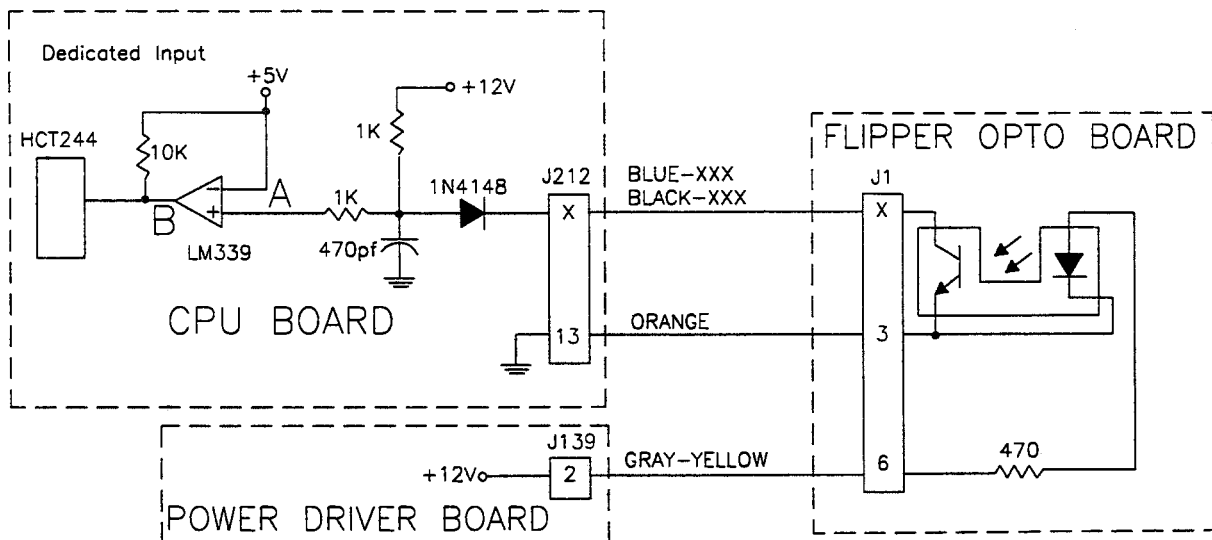
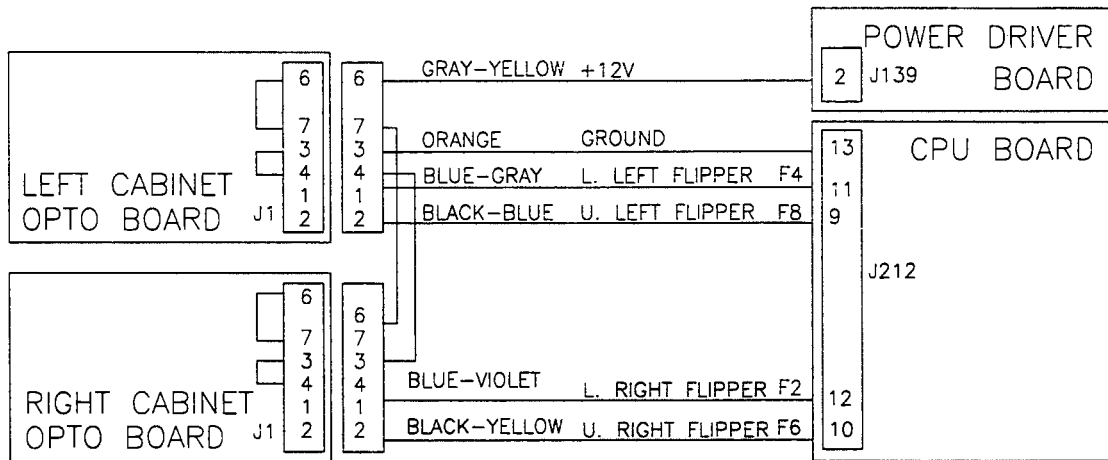

The flipper switch circuits operate similar to the dedicated switch circuit. The circuits are active low and tied to ground through the switch circuit.

When a switch closes, the row side (dedicated input) of the circuit activates. The "+" input to the LM339 drops below +5V, therefore, its output is low. Since the row, (dedicated input) circuit is tied directly to ground through the switch, the switch is considered closed by the microprocessor. When the switch opens, the "+" input to the LM339 is above +5V, its output is high and the row, (dedicated Input) is inactive.

FLIPPER OPTO BOARD ASSEMBLY A-17316

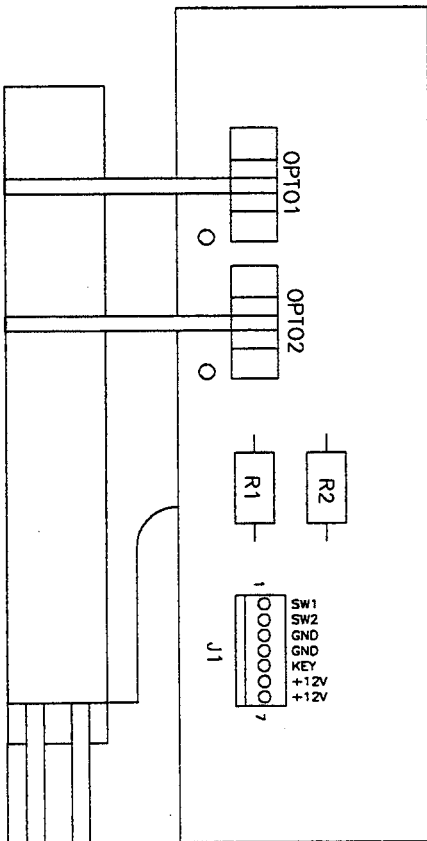

Left Flipper Opto Board Assembly

- J1-1 Black-Blue from CPU board J212-9
- J1-2 Blue-Gray from CPU board J212-11
- J1-3 N/C
- J1-4 Orange from CPU board J212-13
- J1-5 N/C
- J1-6 Gray-Yellow from Power Driver Board J139-2
- J1-7 Gray-Yellow from Power Driver Board J139-2

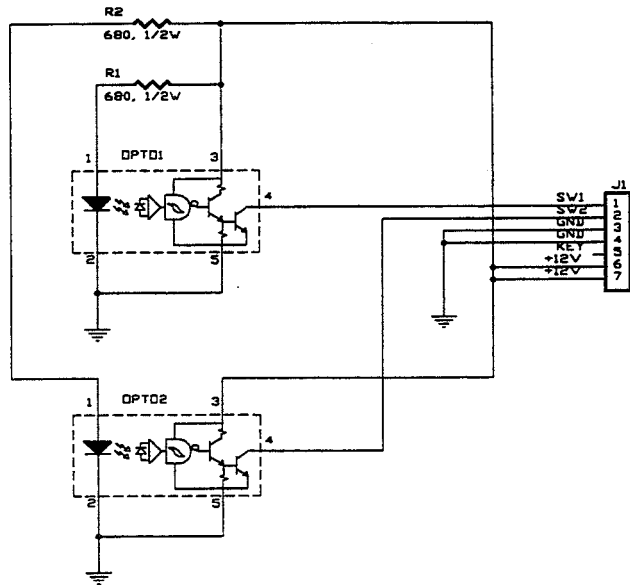

Right Flipper Opto Board Assembly

- J1-1 Black-Yellow from CPU board J212-10
- J1-2 Blue-Violet from CPU board J212-12
- J1-3 Orange from CPU board J212-13
- J1-4 Orange from Left Flipper Opto Board Assy J1-4
- J1-5 N/C
- J1-6 Gray-Yellow from Left Flipper Opto Board Assy J1-6
- J1-7 N/C

**LED BOARD ASSEMBLY
A-16908
(TRANSMITTER-GREEN BOARD)**

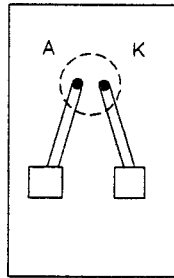

solder side

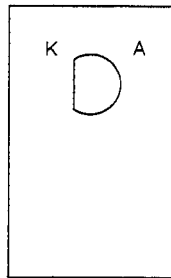

component side

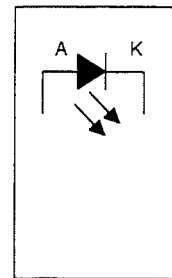

schematic

**PHOTO TRANSISTOR BOARD ASSEMBLY
A-16909
(RECEIVER-BLUE BOARD)**

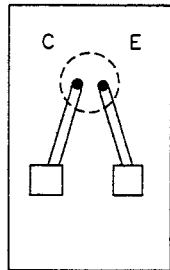

solder side

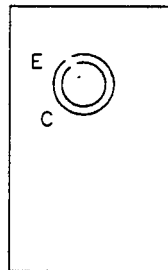

component side

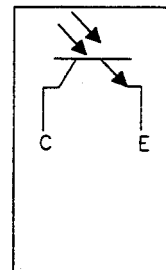

schematic

TYPICAL CIRCUIT DIAGRAM

LED BOARD
Transmitter
1.0-1.4 volts

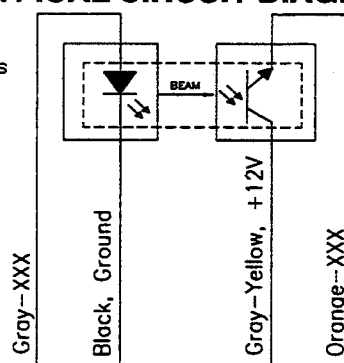
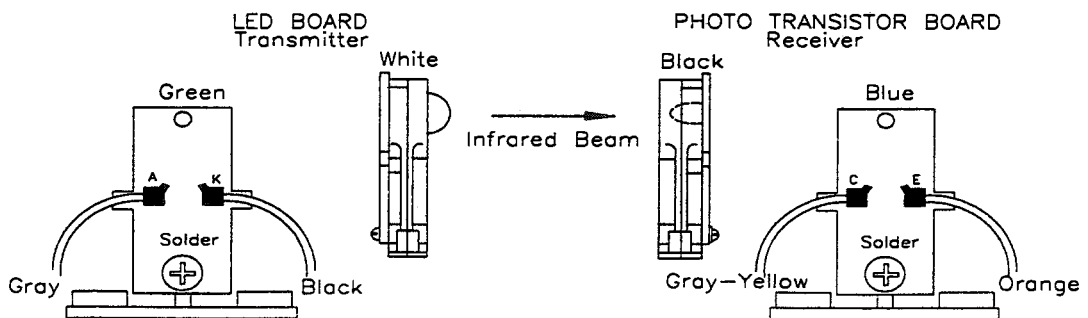
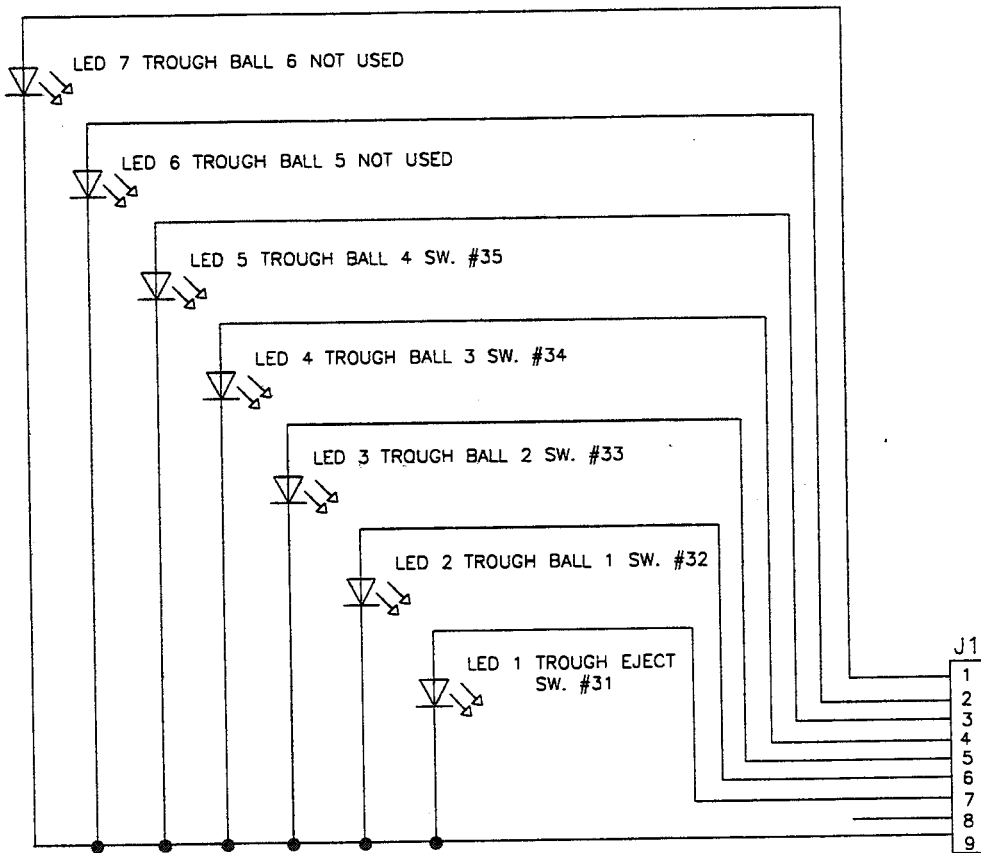
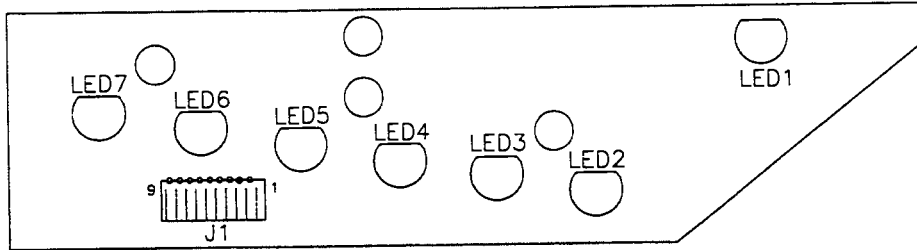

PHOTO TRANSISTOR BOARD
Receiver
0.1-0.7 volts unblocked
11-13 volts blocked



**Trough IR LED Board Assembly
(transmitter - green board)
A-18617-1**



- | | | |
|------|----------|---|
| J1-1 | N/C | |
| J1-2 | N/C | |
| J1-3 | GRY-GRN, | For TROUGH BALL 4 switch #35 from 10-Opto Switch Board J1-3 |
| J1-4 | GRY-BLK, | For TROUGH BALL 3 switch #34 from 10-Opto Switch Board J1-4 |
| J1-5 | GRY-ORG, | For TROUGH BALL 2 switch #33 from 10-Opto Switch Board J1-5 |
| J1-6 | GRY-RED, | For TROUGH BALL 1 switch #32 from 10-Opto Switch Board J1-6 |
| J1-7 | GRY-BRN, | For TROUGH EJECT switch #31 from 10-Opto Switch Board J1-7 |
| J1-8 | KEY | |
| J1-9 | BLK, | Ground from 10-Opto Switch Board J1-9 |

**Trough IR Photo Transistor Board Assembly
(receiver - blue board)
A-18618-1**

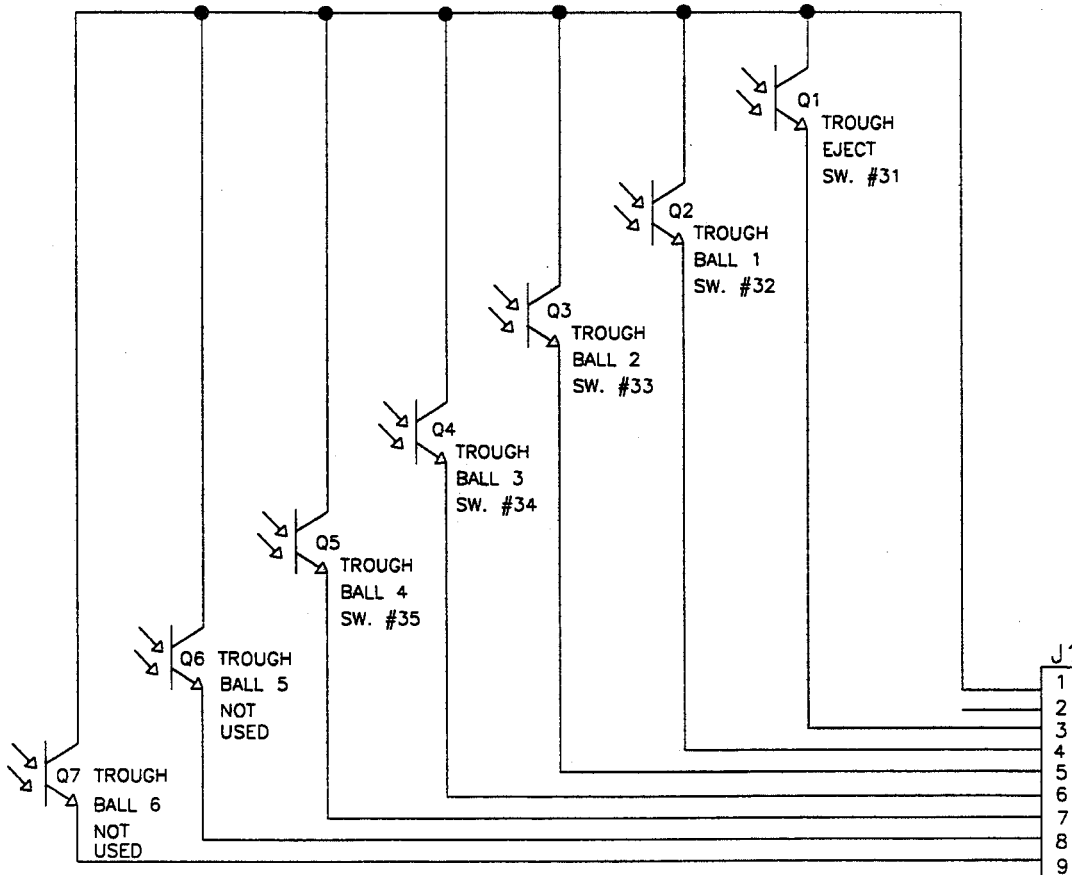
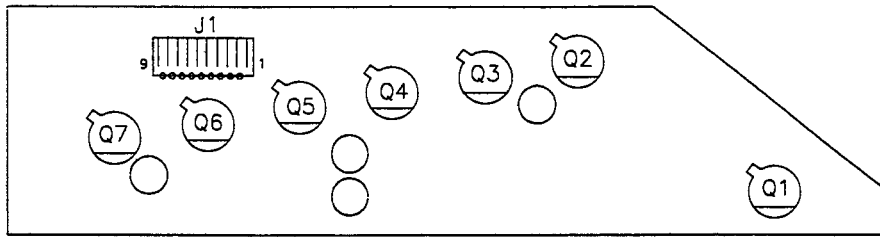

- | | | |
|-------------|----------|---|
| J1-1 | GRY-YEL, | +12V from 10-Opto Switch Board J2-1 |
| J1-2 | KEY | |
| J1-3 | ORG-BRN, | For TROUGH EJECT switch #31 from 10-Opto Switch Board J2-8 |
| J1-4 | ORG-RED, | For TROUGH BALL 1 switch #32 from 10-Opto Switch Board J2-7 |
| J1-5 | ORG-BLK, | For TROUGH BALL 2 switch #33 from 10-Opto Switch Board J2-5 |
| J1-6 | ORG-YEL, | For TROUGH BALL 3 switch #34 from 10-Opto Switch Board J2-4 |
| J1-7 | ORG-GRN, | For TROUGH BALL 4 switch #35 from 10-Opto Switch Board J2-3 |
| J1-8 | N/C | |
| J1-9 | N/C | |

10-Opto Switch Board Assembly A-18159.1

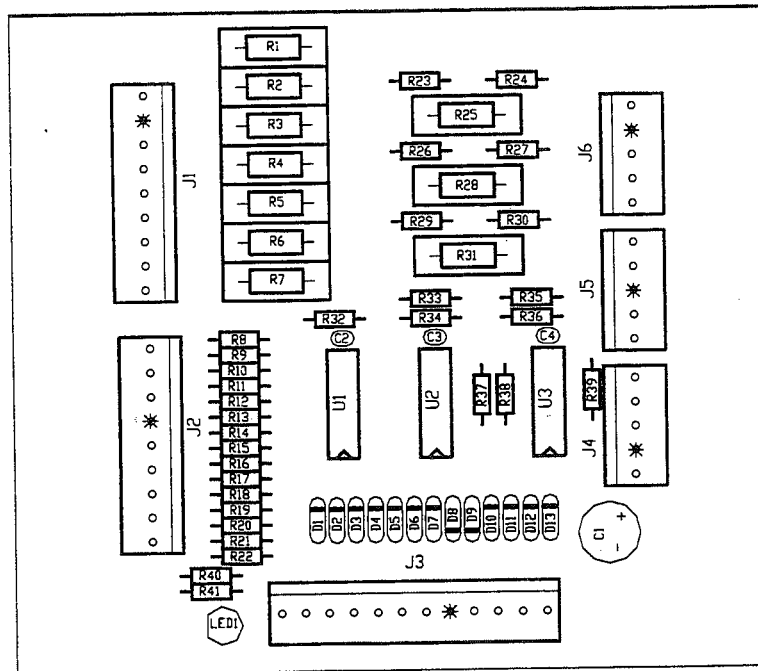

J1-1	N/C	
J1-2	GRY-BLU	To switch #36 LED board
J1-3	GRY-GRN	To switch #35 LED board
J1-4	GRY-BLK	To switch #34 LED board
J1-5	GRY-ORG	To switch #33 LED board
J1-6	GRY-RED	To switch #32 LED board
J1-7	GRY-BRN	To switch #31 LED board
J1-8	KEY	
J1-9	BLK	Ground to LED boards
J2-1	N/C	
J2-2	ORG-BLU	To switch #36 Photo Trans. board
J2-3	ORG-GRN	To switch #35 Photo Trans. board
J2-4	ORG-YEL	To switch #34 Photo Trans. board
J2-5	ORG-BLK	To switch #33 Photo Trans. board
J2-6	KEY	
J2-7	ORG-RED	To switch #32 Photo Trans. board
J2-8	ORG-BRN	To switch #31 Photo Trans. board
J2-9	GRY-YEL	+12V to Photo Trans. boards
J3-1	BLK	Ground from Power Driver J141-3
J3-2	GRY-YEL	+12V from Power Driver J141-2
J3-3	GRN-WHT	Switch Row #4 from CPU J206-4
J3-4	GRN-ORG	Switch Row #3 from CPU J206-3
J3-5	KEY	
J3-6	N/C	
J3-7	WHT-BLU	Switch Col. #6 from CPU J208-7
J3-8	WHT-GRN	Switch Col. #5 from CPU J208-5
J3-9	WHT-YEL	Switch Col. #4 from CPU J208-4
J3-10	WHT-ORG	Switch Col. #3 from CPU J208-3
J3-11	WHT-RED	Switch Col. #2 from CPU J208-2
J3-12	WHT-BRN	Switch Col. #1 from CPU J208-1

J4-1	GRN-ORG	To switch #43 LED board
J4-2	BLK	Ground to switch #43 LED board
J4-3	GRY-YEL	+12 to sw. #43 Photo Trans. board
J4-4	KEY	
J4-5	WHT-ORG	To switch #43 Photo Trans. board
J5-1	GRN-RED	To switch #42 LED board
J5-2	BLK	Ground to switch #42 LED board
J5-3	KEY	
J5-4	GRY-YEL	+12V to sw. #42 Photo Trans board
J5-5	WHT-RED	To switch #42 Photo Trans. board

Switch Individual Playfield Opto Switch Wiring Diagram

This diagram shows the wiring for individual playfield opto switches only. See the next page for the wiring diagram for the ball trough opto switches.

The individual playfield opto switches are:

- Switch 36 Right Popper
- Switch 42 Left Flipper Opto
- Switch 43 Right Flipper Opto

Each of these switches uses a green LED board (p/n A-16908), and a blue Photo Transistor board (p/n A-16909).

OPTO SWITCH OPERATION:

The ball rolls between the LED board and the Photo Transistor board and breaks the beam. The broken beam 'makes' the switch.

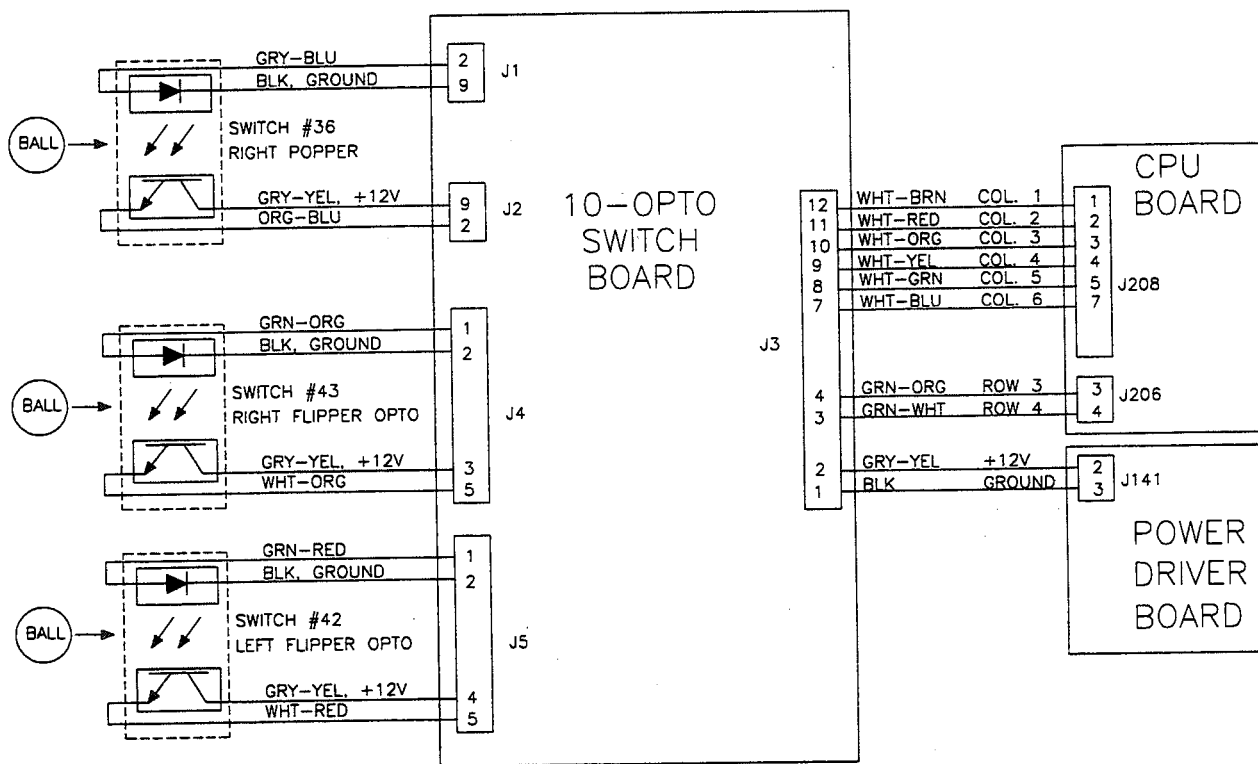

Ball Trough Opto Switches Wiring Diagram

This diagram shows the opto switches for the ball trough assembly only. See the previous page for the individual playfield opto switches.

The ball trough opto switches are:

- Switch 31 Trough Eject
- Switch 32 Trough Ball 1
- Switch 33 Trough Ball 2
- Switch 34 Trough Ball 3
- Switch 35 Trough Ball 4

The ball trough switches use a green LED board (p/n A-18617-1), and a blue Photo Transistor board (p/n A-18618-1).

OPTO SWITCH OPERATION:

The ball rolls between the LED board and the Photo Transistor board and breaks the beam. The broken beam 'makes' the switch.

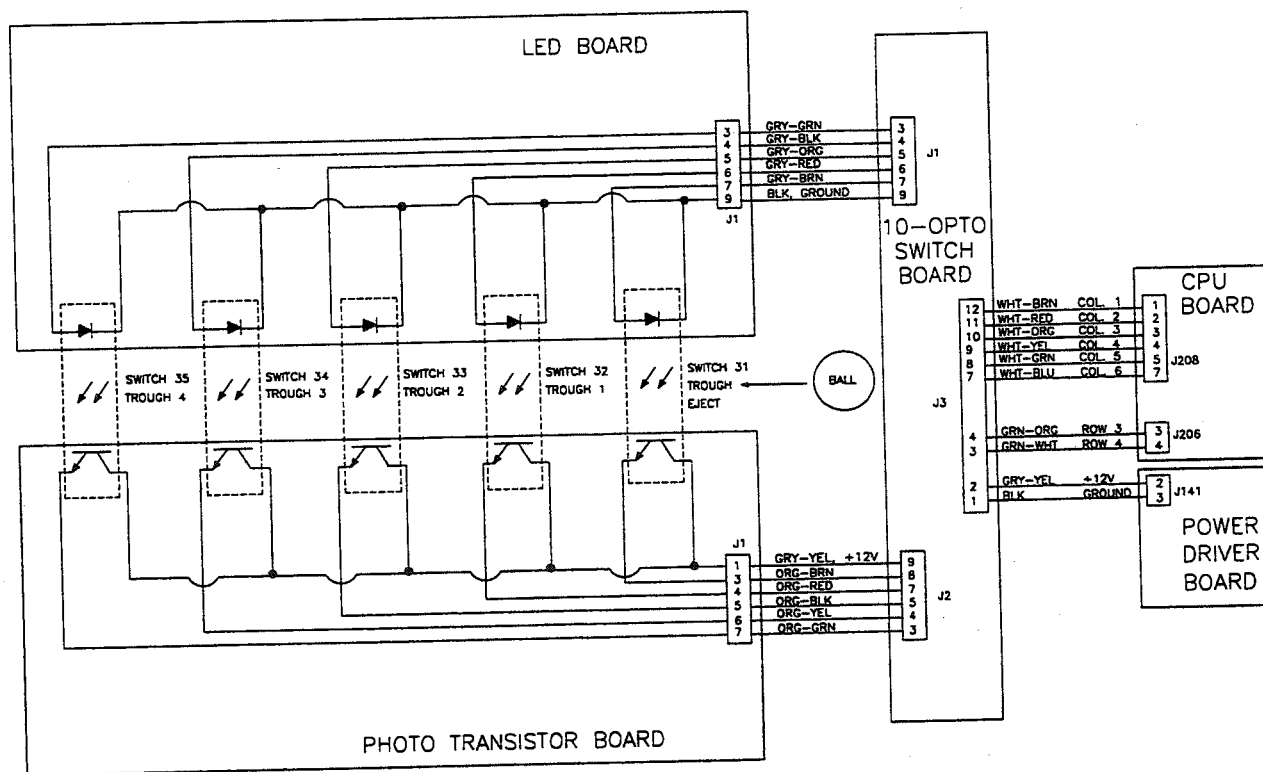

Motor EMI Board A-15542 (For Frankenstein Motor and Up/Down Bank Motor)

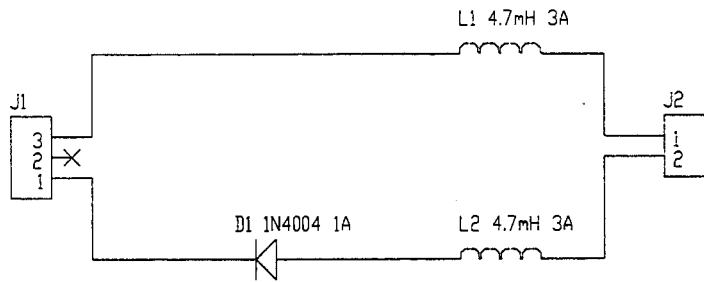
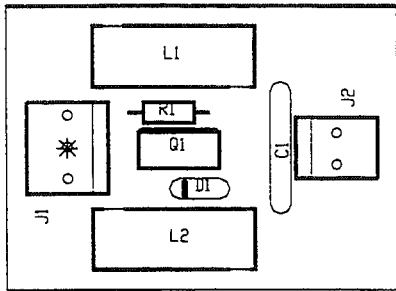

FRANKENSTEIN MOTOR

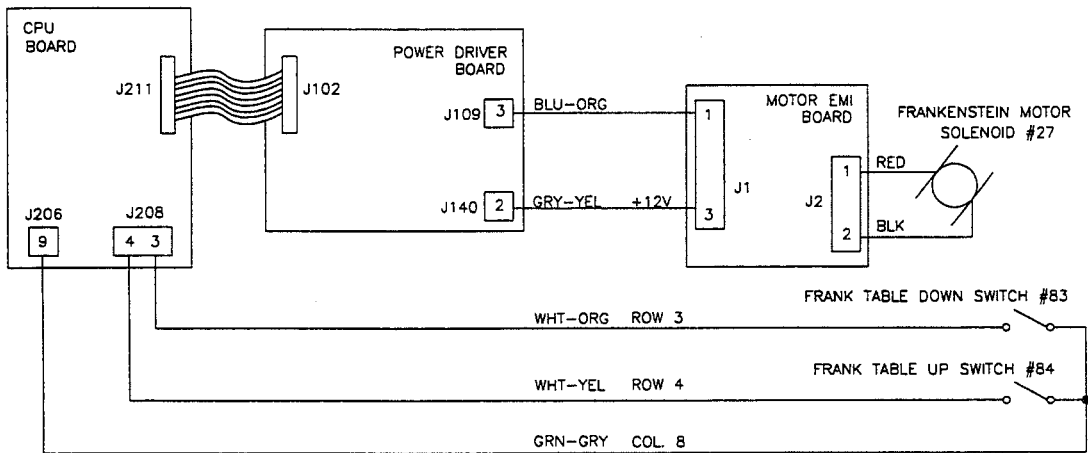

J1-1 BLU-ORG From Power Driver board J109-3
J1-2 N/C
J1-3 GRY-YEL +12V from Power Driver Board J140-2

J2-1 RED To Motor "+" Terminal
J2-2 BLK To Motor "-" Terminal

UP/DOWN BANK MOTOR

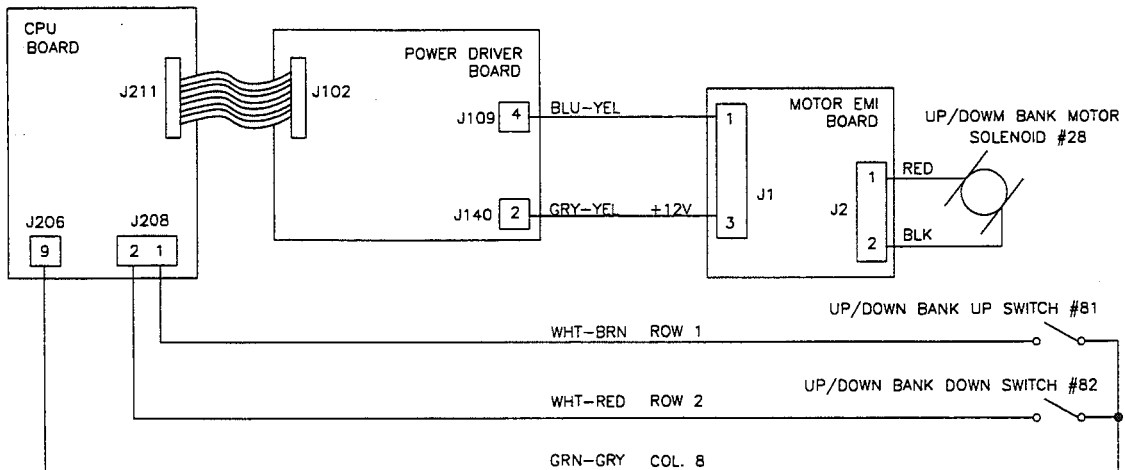

J1-1 BLU-YEL From Power Driver board J109-4
J1-2 N/C
J1-3 GRY-YEL +12V from Power Driver Board J140-2

J2-1 RED To Motor "+" Terminal
J2-2 BLK To Motor "-" Terminal

D.C. Motor Control Assembly A-16120 (For Dracula Motor)

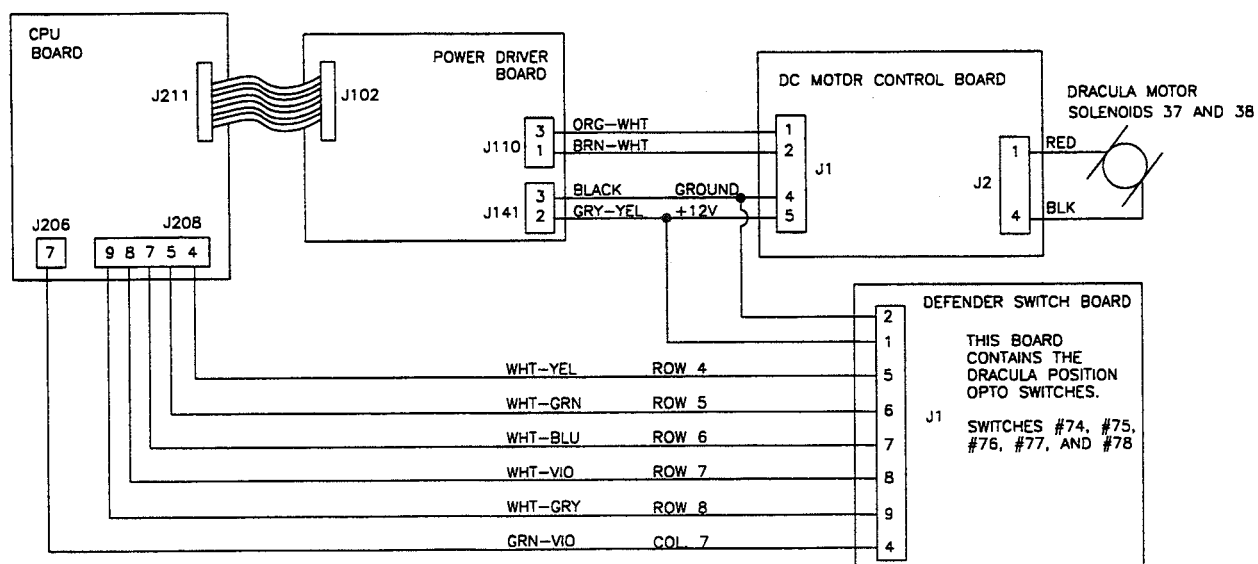
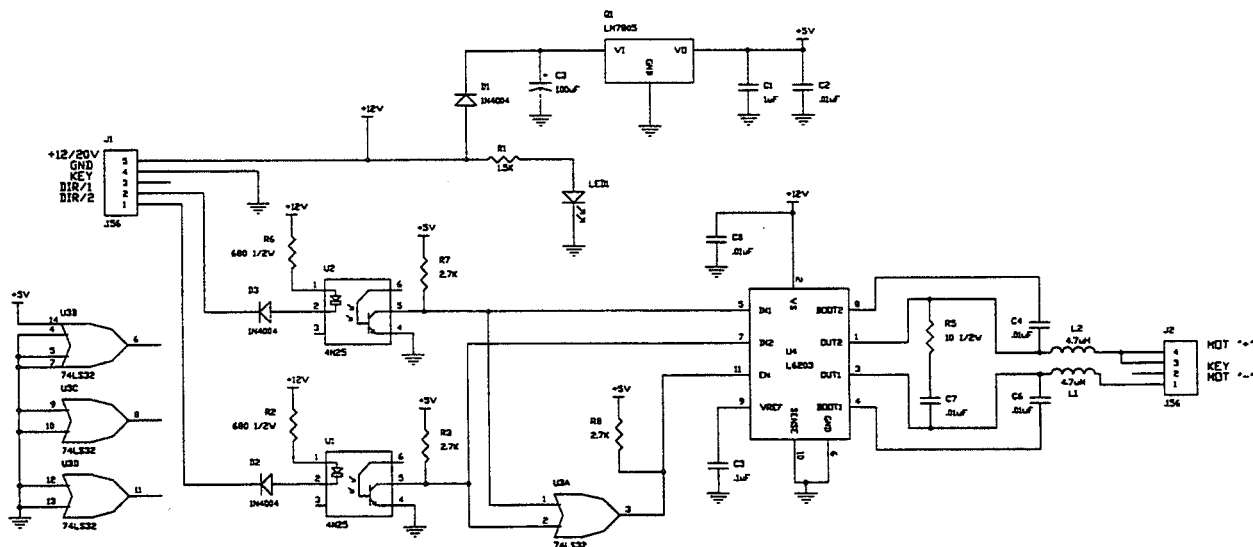
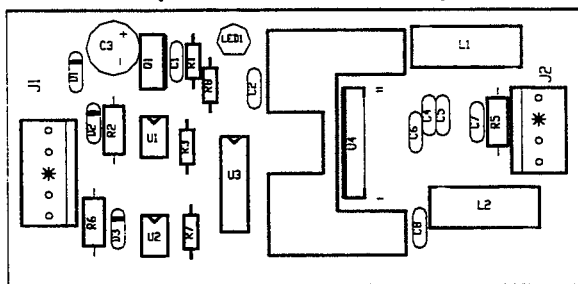

- | | | | | | |
|------|---------|---------------------------------------|------|-----|-----------------------|
| J1-1 | ORG-WHT | From Power Driver board J110-3 | J2-1 | RED | To Motor "+" Terminal |
| J1-2 | BRN-WHT | From Power Driver board J110-1 | J2-2 | KEY | |
| J1-3 | KEY | | J2-3 | NC | |
| J1-4 | BLK | Ground from Power Driver board J141-3 | J2-4 | BLK | To Motor "-" Terminal |
| J1-5 | GRY-YEL | +12V from Power Driver Board J141-2 | | | |

**Defender Switch PCB Assembly
A-21402
(For Dracula Assembly Position Location)
See previous page for circuit diagram.**

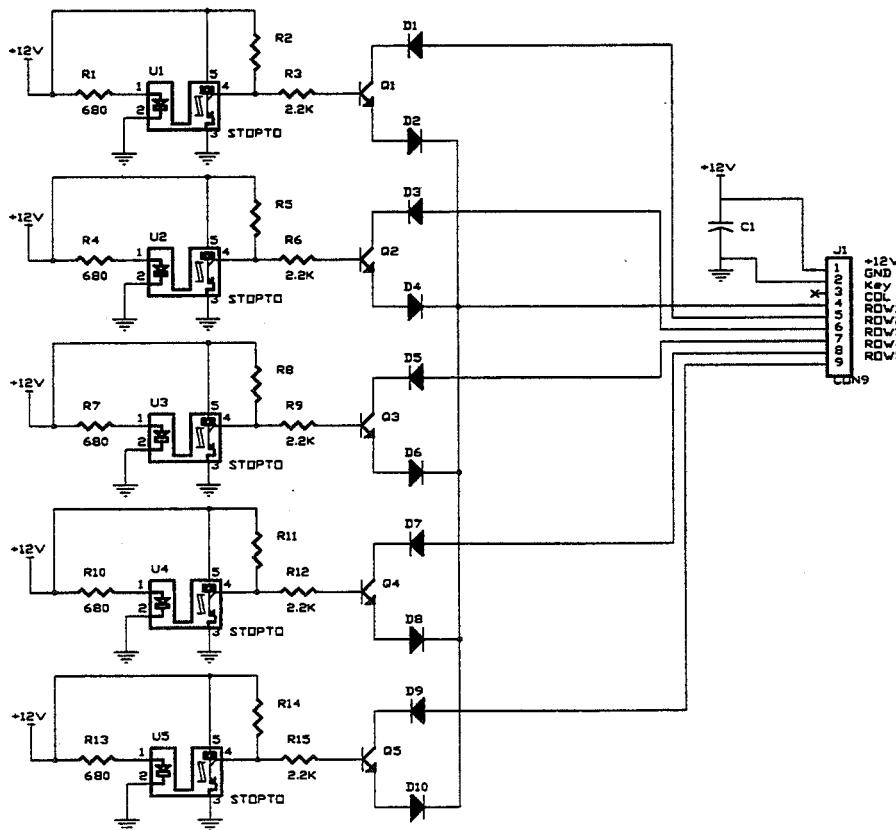
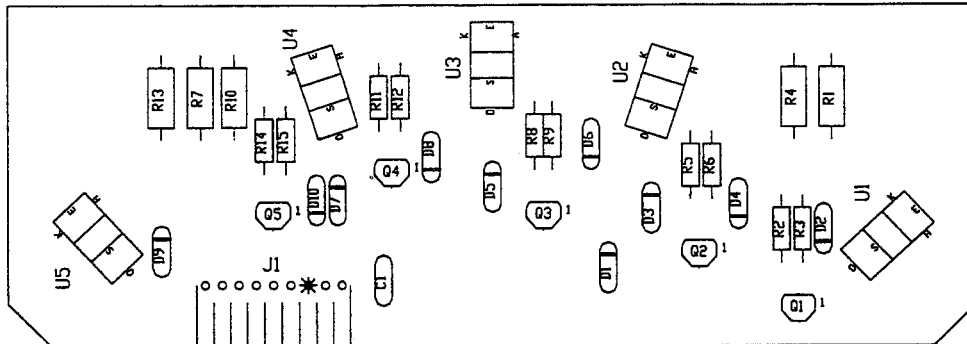

- J1-1 GRY-YEL From Power Driver board J141-2
- J1-2 BLK From Power Driver board J141-3
- J1-3 KEY
- J1-4 GRN-VIO Switch Col. 7 from CPU board J206-7
- J1-5 WHT-YEL Switch Row 4 from CPU board J208-4
- J1-6 WHT-GRN Switch Row 5 from CPU board J208-5
- J1-7 WHT-BLU Switch Row 6 from CPU board J208-7
- J1-8 WHT-VIO Switch Row 7 from CPU board J208-8
- J1-9 WHT-GRY Switch Row 8 from CPU board J208-9

Auto Adjust Eddy Sensor A-22149-1 (For Left & Right Proximity Sensor Switches)

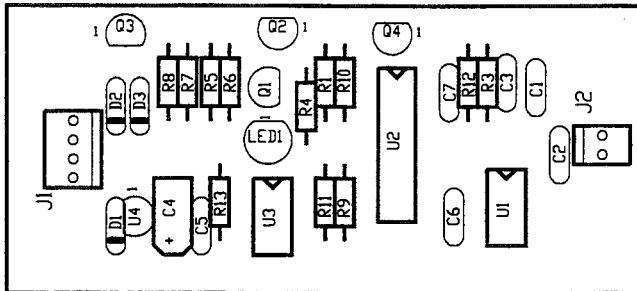

LEFT FLIPPER PROXIMITY SENSOR SWITCH

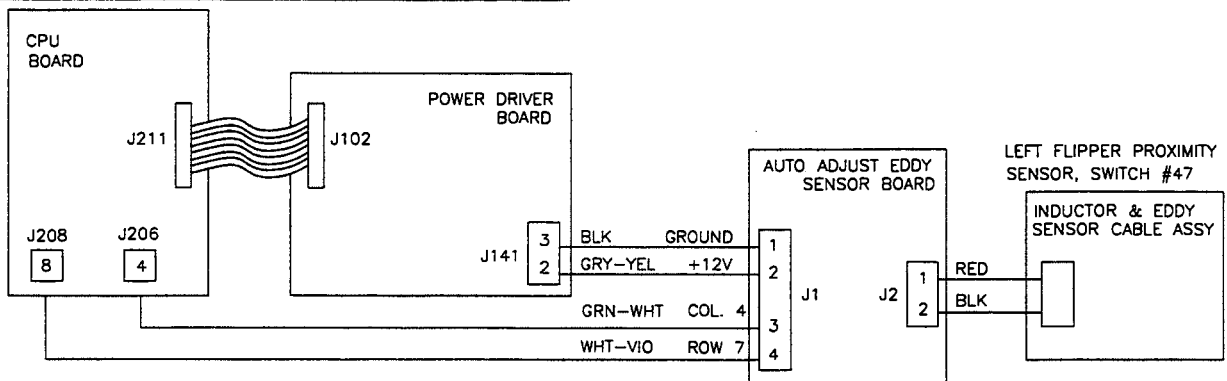

- J1-1 BLK From Power Driver board J141-3
- J1-2 GRY-YEL From Power Driver board J141-2
- J1-3 GRN-WHT From CPU board J206-4
- J1-4 WHT-VIO From CPU board J208-8

- J2-1 RED To Inductor & Eddy Sensor Cable Assy
- J2-2 BLK To Inductor & Eddy Sensor Cable Assy

RIGHT FLIPPER PROXIMITY SENSOR SWITCH

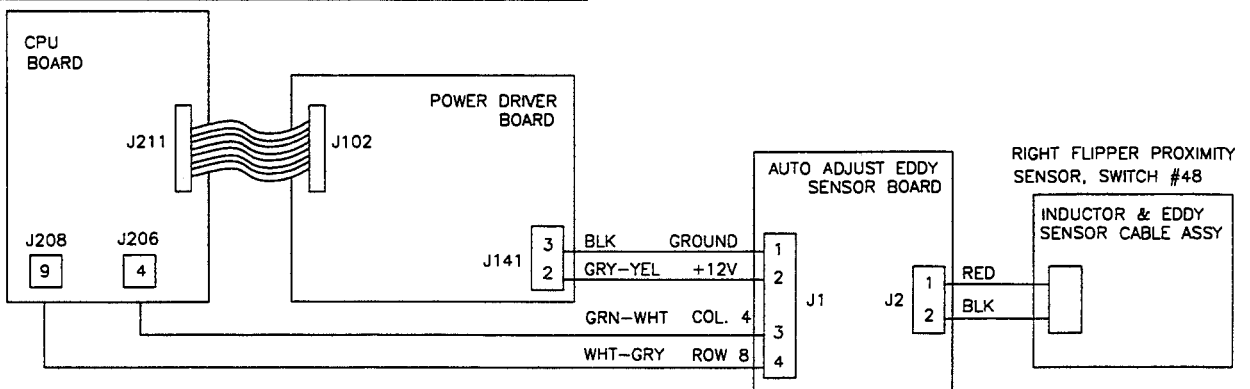

- J1-1 BLK From Power Driver board J141-3
- J1-2 GRY-YEL From Power Driver board J141-2
- J1-3 GRN-WHT From CPU board J206-4
- J1-4 WHT-GRY From CPU board J208-9

- J2-1 RED To Inductor & Eddy Sensor Cable Assy
- J2-2 BLK To Inductor & Eddy Sensor Cable Assy

Auto Adjust Eddy Sensor Schematic A-22149-1

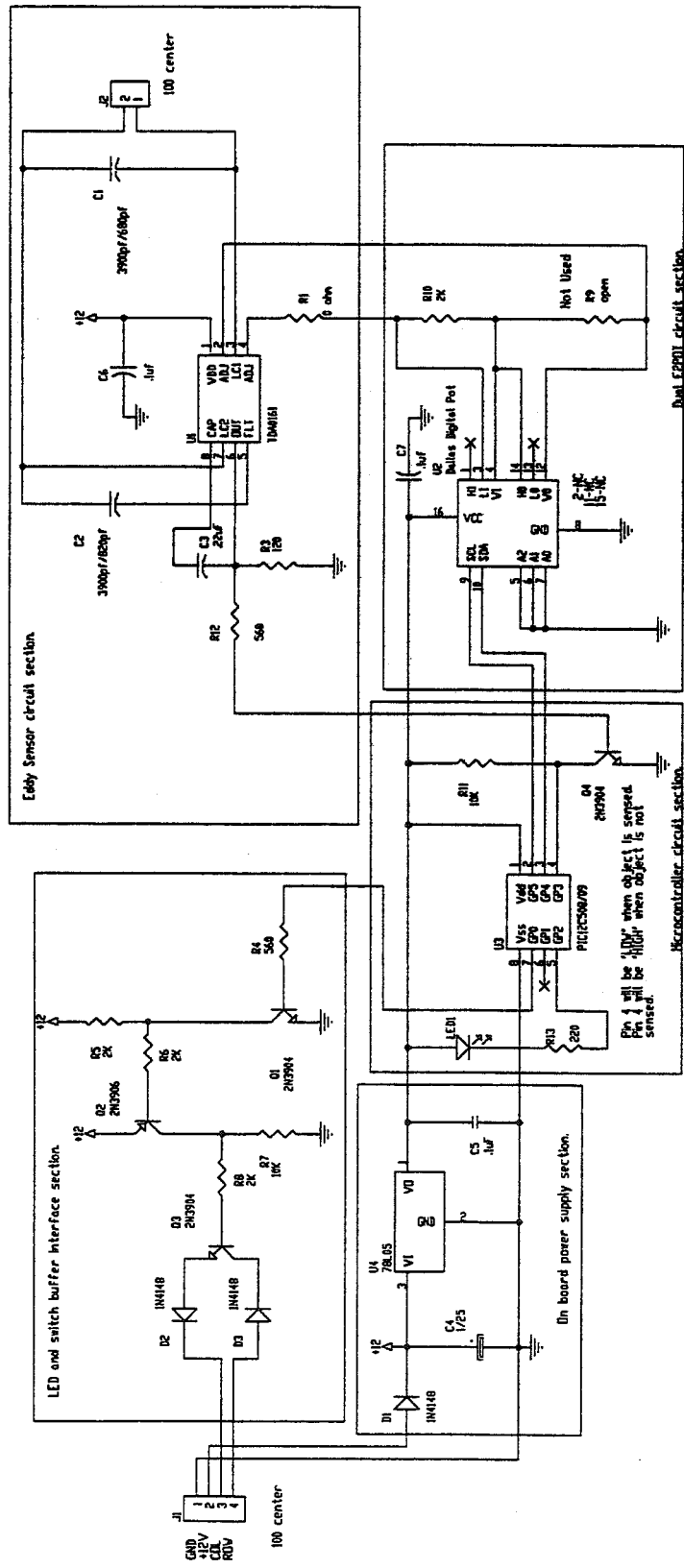

Coin Door Interface Board A-20580

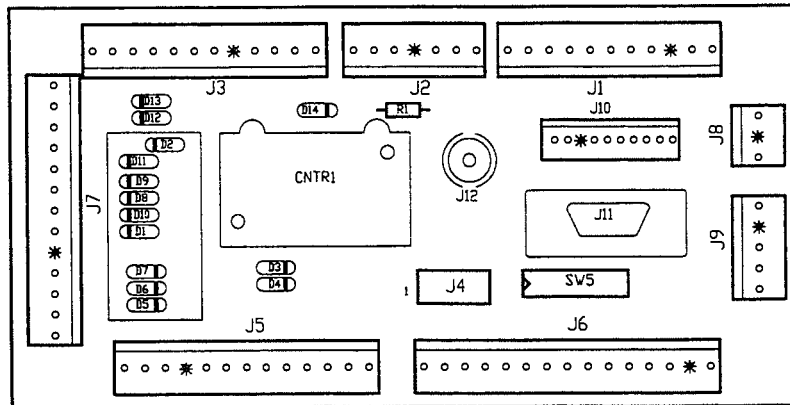

J1-1	ORG-GRY	Dedicated sw row #8 from CPU J205-9.	J6	NOT USED
J1-2	ORG-VIO	Dedicated sw row #7 from CPU J205-8.	J7-1	YEL-GRY Lamp column #8 to cabinet.
J1-3	ORG-BLU	Dedicated sw row #6 from CPU J205-7.	J7-2	N/C
J1-4	ORG-GRN	Dedicated sw row #5 from CPU J205-6.	J7-3	RED-BLU Lamp row #6 to cabinet.
J1-5	ORG-YEL	Dedicated sw row #4 from CPU J205-4.	J7-4	RED-GRY Lamp row #8 to cabinet.
J1-6	ORG-BLK	Dedicated sw row #3 from CPU J205-3.	J7-5	KEY
J1-7	ORG-RED	Dedicated sw row #2 from CPU J205-2.	J7-6	GRN-BRN Switch column #1 to cabinet.
J1-8	ORG-BRN	Dedicated sw row #1 from CPU J205-1.	J7-7	N/C
J1-9	KEY		J7-8	WHT-ORG Switch row #3 to cabinet.
J1-10	BLK	Ground from CPU J205-10	J7-9	N/C
J1-11	ORG-WHT	Switch enable from CPU J205-12.	J7-10	WHT-BRN Switch row #1 to cabinet.
J2-1	BLK	Ground from Power Driver board J139-3.	J7-11	WHT-ORG Switch row #3 to cabinet.
J2-2	GRY-YEL	+12VAC from Power Driver board J139-2.	J7-12	N/C
J2-3	WHT-VIO	6.8VAC from Power Driver board J104-1.	J7-13	N/C
J2-4	KEY		J8-1	WHT Switch row to cabinet for Slam tilt.
J2-5	VIO	For G.I. from Power Driver board J104-3.	J8-2	KEY
J2-6	N/C		J8-3	GRN Switch column to cabinet for Slam Tilt.
J2-7	BLK-WHT	Signal for coin meter from Power Driver board J139-5.	J9-1	WHT-YEL Switch row #4 to Plumb Bob Tilt.
J3-1	GRN-BRN	Switch column #1 from CPU J212-1.	J9-2	KEY
J3-2	GRN-RED	Switch column #2 from CPU J212-2.	J9-3	GRN-BRN Switch column #1 to Plumb Bob Tilt.
J3-3	WHT-BRN	Switch row #1 from CPU J212-4.	J9-4	WHT-RED Switch row #2 to Interlock Switch.
J3-4	WHT-RED	Switch row #2 from CPU J212-5.	J7-5	GRN-RED Switch column #2 to Interlock Switch.
J3-5	WHT-ORG	Switch row #3 from CPU J212-6.	J10	Ribbon cable To cash flow mechanism (if used).
J3-6	WHT-YEL	Switch row #4 from CPU J212-7.		
J3-7	KEY			
J3-8	YEL-GRY	Lamp col #8 from Pwr Drvr brd J122-3.		
J3-9	RED-BLU	Lamp row #6 from Pwr Drvr brd J125-7.		
J3-10	RED-VIO	Lamp row #7 from Pwr Drvr brd J125-8.		
J3-11	RED-GRY	Lamp row #8 from Pwr Drvr brd J125-9.		
J4	NOT USED			
J5-1	VIO	Return to coin door.		
J5-2	WHT-VIO	6.8VAC for G.I. to coin door.		
J5-3	BLK	Ground to coin door.		
J5-4	ORG-BRN	Dedicated switch row #1 to coin door.		
J5-5	ORG-RED	Dedicated switch row #2 to coin door.		
J5-6	ORG-BLK	Dedicated switch row #3 to coin door.		
J5-7	ORG-GRN	Dedicated switch row #5 to coin door.		
J5-8	ORG-BLU	Dedicated switch row #6 to coin door.		
J5-9	ORG-VIO	Dedicated switch row #7 to coin door.		
J5-10	KEY			
J5-11	ORG-GRY	Dedicated switch row #8 to coin door.		
J5-12	GRN-RED	Switch column #2 to coin door Slam Tilt.		
J5-13	WHT-BRN	Switch row #1 to coin door Slam Tilt.		

Coin Door Interface Board Schematic A-20580

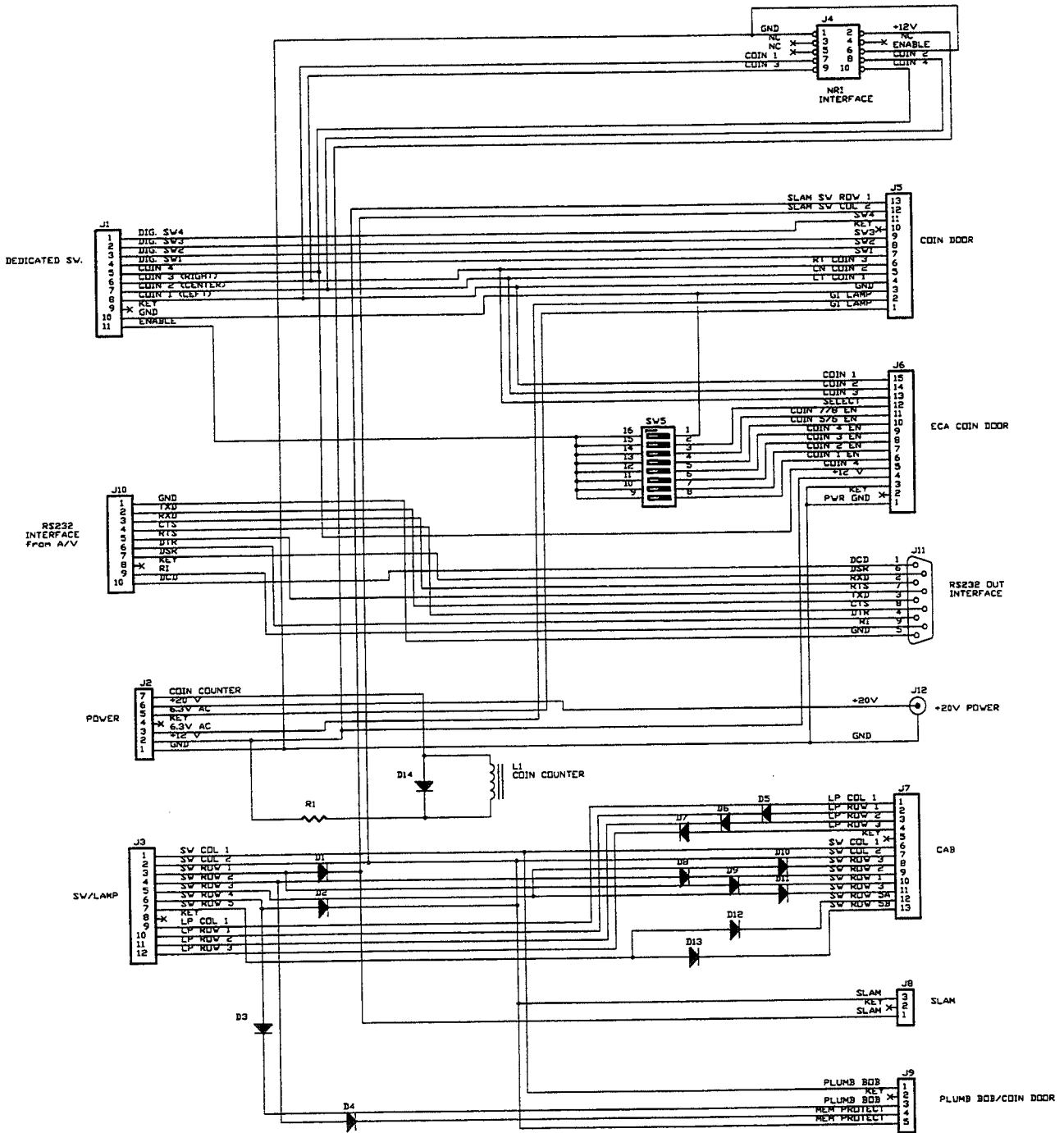

Security CPU Board Assembly A-21377-50065

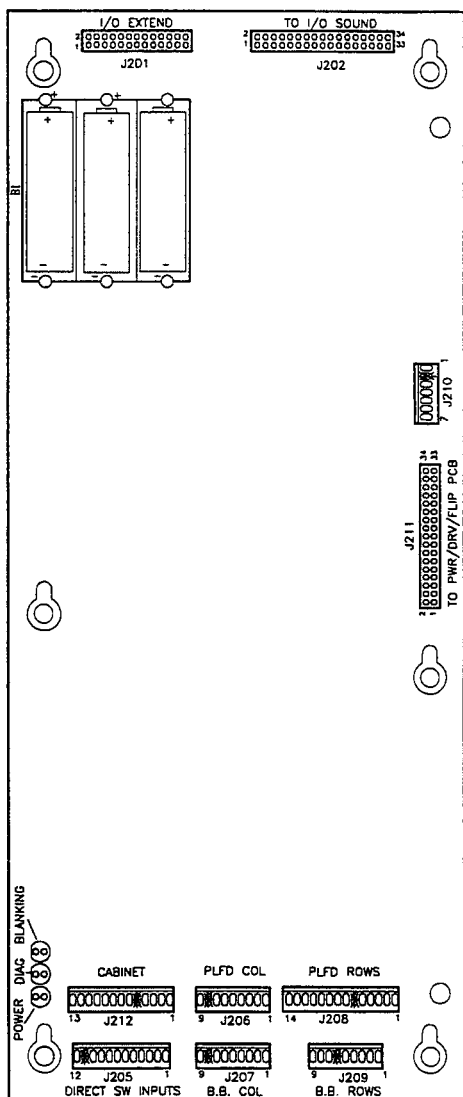

J201 26-pin ribbon cable Data to/from J602.

J202 34-pin ribbon cable Data to/from J601.

J203 & J204 NOT USED

J205-1 ORG-BRN Dedicate sw row #1 to Coin Door brd J1-8.
 J205-2 ORG-RED Dedicate sw row #2 to Coin Door brd J1-7.
 J205-3 ORG-BLK Dedicate sw row #3 to Coin Door brd J1-6.
 J205-4 ORG-YEL Dedicate sw row #4 to Coin Door brd J1-5.
 J205-5 N/C
 J205-6 ORG-GRN Dedicate sw row #5 to Coin Door brd J1-4.
 J205-7 ORG-BLU Dedicate sw row #6 to Coin Door brd J1-3.
 J205-8 ORG-VIO Dedicate sw row #7 to Coin Door brd J1-2.
 J205-9 ORG-GRY Dedicate sw row #8 to Coin Door brd J1-1.
 J205-10 BLK Ground to Coin Door board J1-10.
 J205-11 KEY
 J205-12 ORG-WHT Switch enable to Coin Door brd J1-11.

J206-1 GRN-BRN Switch column #1 to playfield switches.
 J206-2 GRN-RED Switch column #2 to playfield switches.
 J206-3 GRN-ORG Switch column #3 to playfield switches.
 J206-4 GRN-WHT Switch column #4 to playfield switches.
 J206-5 GRN-BLK Switch column #5 to playfield switches.
 J206-6 GRN-BLU Switch column #6 to playfield switches.
 J206-7 GRN-VIO Switch column #7 to playfield switches.
 J206-8 KEY
 J206-9 GRN-GRY Switch Column #8 to playfield switches

J207 NOT USED

J208-1 WHT-BRN Switch row #1 to playfield switches.
 J208-2 WHT-RED Switch row #2 to playfield switches.
 J208-3 WHT-ORG Switch row #3 to playfield switches.
 J208-4 WHT-YEL Switch row #4 to playfield switches.
 J208-5 WHT-GRN Switch row #5 to playfield switches.
 J208-6 KEY
 J208-7 WHT-BLU Switch row #6 to playfield switches.
 J208-8 WHT-VIO Switch row #7 to playfield switches.
 J208-9 WHT-GRY Switch row #8 to playfield switches.
 J208-10 N/C
 J208-11 N/C
 J208-12 BLK-BLU To lower left E.O.S. switch #F3.
 J208-13 BLK-GRN To lower right E.O.S. switch #F1.
 J208-14 ORG E.O.S. switch ground.

J209 NOT USED

J210-1 BLK Ground from Power Driver brd J101-5, 7.
 J210-2 KEY
 J210-3 BLK Ground from Power Driver brd J101-5, 7.
 J210-4 GRY +5V from Power Driver board J101-3, 4.
 J210-5 GRY +5V from Power Driver board J101-3, 4.
 J210-6 GRY-GRN +12V from Power Driver board J101-1, 2.
 J210-7 GRY-GRN +12V from Power Driver board J101-1, 2.

J211 34-pin ribbon cable Data to/from J102 & J1 Aux 8-driver board.

J212-1 GRN-BRN Switch col. #1 to Coin Door board J3-1.
 J212-2 GRN-RED Switch col. #2 to Coin Door board J3-2.
 J212-3 N/C
 J212-4 WHT-BRN Switch row #1 to Coin Door board J3-3.
 J212-5 KEY
 J212-6 WHT-RED Switch row #2 to Coin Door board J3-4.
 J212-7 WHT-ORG Switch row #3 to Coin Door board J3-5.
 J212-8 WHT-YEL Switch row #4 to Coin Door board J3-6.
 J212-9 BLK-BLU To switch #F8 left flipper opto brd J1-1.
 J212-10 BLK-YEL To switch #F6 right flipper opto brd J1-1.
 J212-11 BLU-GRY To switch #F4 left flipper opto brd J1-2.
 J212-12 BLU-VIO To switch #F2 right flipper opto brd J1-2.
 J212-13 ORG Ground to left flipper opto board J1-4.

Audio Visual Board Assembly A-20516-50065

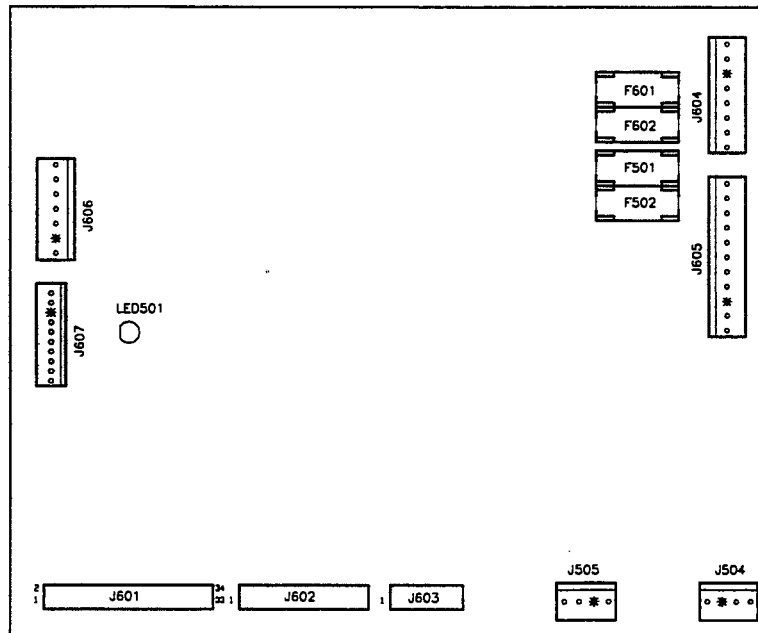

J601	34-pin ribbon cable	Data to/from CPU J202.	J504-1	BLK-YEL	Signal to speaker.
J602	26-pin ribbon cable	Data to/from CPU J201.	J504-2	KEY	
J603	14-pin ribbon cable	Data to/from Dot Matrix Display Driver board.	J504-3	N/C	
			J504-4	BLK	Signal to speaker.
J604-1	ORG	+125V to Dot Matrix Display	J505-1	BLK-YEL	Signal to speaker.
J604-2	BLU	+113V to Dot Matrix Display	J505-2	KEY	
J604-3	KEY		J505-3	N/C	
J604-4	BLK	Ground to Dot Matrix Display	J505-4	BLK	Signal to speaker.
J604-5	BLK	Ground to Dot Matrix Display			
J604-6	GRY	+5V to Dot Matrix Display			
J604-7	GRY-YEL	+12V to Dot Matrix Display			
J604-8	BRN	+62V to Dot Matrix Display			
J605-1	WHT	80VAC from transformer secondary.			
J605-2	WHT	80VAC from transformer secondary.			
J605-3	VIO	100VAC from transformer secondary.			
J605-4	VIO	100VAC from transformer secondary.			
J605-5	GRY-WHT	18VAC from transformer secondary.			
J605-6	GRY-WHT	Loop from J605-7.			
J605-7	GRY	18VAC from transformer secondary.			
J605-8	GRY	Loop from J605-7.			
J605-9	KEY				
J605-10	GRY-GRN	18VAC from transformer secondary.			
J605-11	GRY-GRN	Loop from J605-10.			
J606-1	BLK	Ground from Power Driver brd J101-7.			
J606-2	KEY				
J606-3	BLK	Ground from Power Driver brd J101-5.			
J606-4	GRY	+5V from Power Driver board J101-4.			
J606-5	GRY	+5V from Power Driver board J101-3.			
J606-6	GRY-GRN	+12V from Power Driver board J101-2.			
J606-7	GRY-GRN	+12V from Power Driver board J101-1.			
J607	NOT USED				

Power Driver Board Assembly A-20028

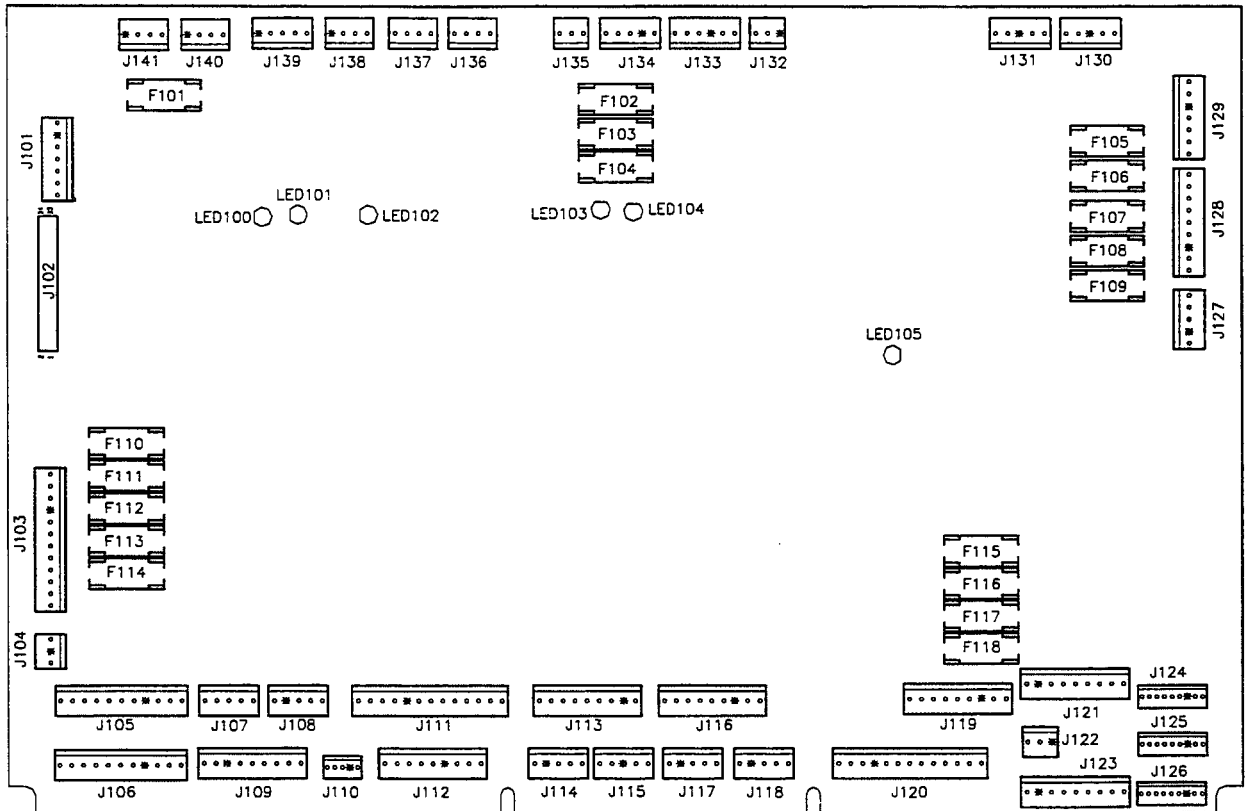

J101-1	GRY-GRN	+12V to J210-6, 7; J606-1.	J105-1	BRN	Return for G.I. to insert panel.
J101-2	GRY-GRN	+12V to J210-6, 7; J606-2.	J105-2	ORG	Return for G.I. to insert panel.
J101-3	GRY	+5V to J210-4, 5; J3-1, 3; J606-3.	J105-3	YEL	Return for G.I. to insert panel.
J101-4	GRY	+5V to J210-4, 5; J3-1, 3; J606-4.	J105-4	KEY	
J101-5	BLK	Ground to J210-1, 3; J606-5.	J105-5	N/C	
J101-6	KEY		J105-6	N/C	
J101-7	BLK	Ground to J210-1,3; J606-7.	J105-7	WHT-BRN	6.8VAC for G.I. to insert panel.
			J105-8	WHT-ORG	6.8VAC for G.I. to insert panel.
J102	34-pin ribbon cable	Data to/from CPU J211.	J105-9	WHT-YEL	6.8VAC for G.I. to insert panel.
			J105-10	N/C	
J103-1	YEL-WHT	6.8Vac from transformer secondary.	J105-11	N/C	
J103-2	WHT-BRN	6.8Vac from transformer secondary.	J106-1	N/C	
J103-3	WHT-BRN	6.8Vac from transformer secondary.	J106-2	N/C	
J103-4	WHT-ORG	6.8Vac from transformer secondary.	J106-3	N/C	
J103-5	WHT-YEL	6.8Vac from transformer secondary.	J106-4	KEY	
J103-6	WHT-YEL	6.8Vac from transformer secondary.	J106-5	GRN	Return for G.I. to playfield.
J103-7	ORG	6.8Vac from transformer secondary.	J106-6	VIO	Return for G.I. to playfield.
J103-8	ORG	6.8Vac from transformer secondary.	J106-7	N/C	
J103-9	KEY		J106-8	N/C	
J103-10	GRN	6.8Vac from transformer secondary.	J106-9	N/C	
J103-11	BRN	6.8Vac from transformer secondary.	J106-10	WHT-GRN	6.8VAC for G.I. to playfield.
J103-12	BRN	6.8Vac from transformer secondary.	J106-11	WHT-VIO	6.8VAC for G.I. to playfield.
J104-1	WHT-VIO	6.8VAC for G.I. to Coin Door brd J2-5.	J107	NOT USED	
J104-2	KEY		J108-1	BLU-BRN	Solenoid #25 drive to insert flasher
J104-3	VIO	Return for G.I. to Coin Door board J2-3.	J108-2	N/C	
			J108-3	N/C	
			J108-4	KEY	
			J108-5	N/C	

Power Driver Board Continued...

J109-1	BLU-BRN	Solenoid #25 drive to playfield flasher	J119-1	RED-GRN	+50V to lower right flipper coil.
J109-2	BLU-RED	Solenoid #26 drive to playfield flasher	J119-2	RED-GRN	Loop from J119-1.
J109-3	BLU-ORG	Solenoid #27 drive to playfield flasher	J119-3	KEY	
J109-4	BLU-YEL	Solenoid #28 drive to playfield flasher	J119-4	RED-BLU	+50V to lower left flipper coil.
J109-5	N/C		J119-5	RED-BLU	Loop from J119-4.
J109-6	N/C		J119-6	N/C	
J109-7	KEY		J119-7	N/C	
J109-8	N/C		J119-8	N/C	
J109-9	N/C		J119-9	N/C	
J110-1	BRN-WHT	Solenoid #37 drive to DC Motor Control	J120-1	N/C	
J110-2	KEY		J120-2	N/C	
J110-3	ORG-WHT	Solenoid #38 drive to DC Motor Control	J120-3	N/C	
J110-4	YEL-WHT	NOT USED	J120-4	N/C	
J110-5	BLU-WHT	NOT USED	J120-5	N/C	
J111-1	BLK-BRN	Solenoid #17 drive to playfield flasher	J120-6	N/C	
J111-2	BLK-RED	Solenoid #18 drive to playfield flasher	J120-7	ORG-BLU	Solenoid #32 hold drive to low left flipper
J111-3	BLK-ORG	Solenoid #19 drive to playfield flasher	J120-8	N/C	
J111-4	BLK-YEL	Solenoid #20 drive to playfield flasher	J120-9	YEL-BLU	Solenoid #31 power drive to low left flipper
J111-5	BLU-GRN	Solenoid #21 drive to playfield flasher	J120-10	KEY	
J111-6	BLU-BLK	Solenoid #22 drive to playfield flasher	J120-11	ORG-GRN	Solenoid #30 hold drive to low right flipper
J111-7	BLU-VIO	Solenoid #23 drive to playfield flasher	J120-12	N/C	
J111-8	BLU-GRY	Solenoid #24 drive to playfield flasher	J120-13	YEL-GRN	Solenoid #29 power drive to low right flipper
J111-9	KEY		J121	NOT USED	
J111-10	N/C		J122-1	KEY	
J111-11	N/C		J122-2	N/C	
J111-12	N/C		J122-3	YEL-GRY	Lamp column #8 to cabinet
J111-13	N/C		J123-1	YEL-BRN	Lamp column #1 to playfield
J112-1	BLK-BRN	Solenoid #17 drive to insert flasher	J123-2	YEL-RED	Lamp column #2 to playfield
J112-2	BLK-RED	Solenoid #18 drive to insert flasher	J123-3	YEL-ORG	Lamp column #3 to playfield
J112-3	BLK-ORG	Solenoid #19 drive to insert flasher	J123-4	YEL-BLK	Lamp column #4 to playfield
J112-4	KEY		J123-5	YEL-GRN	Lamp column #5 to playfield
J112-5	BLK-YEL	Solenoid #20 driver to insert flasher	J123-6	YEL-BLU	Lamp column #6 to playfield
J112-6	N/C		J123-7	YEL-VIO	Lamp column #7 to playfield
J112-7	BLU-BLK	Solenoid #22 driver to insert flasher	J123-8	KEY	
J112-8	N/C		J123-3	YEL-GRY	Lamp column #8 to playfield
J112-9	N/C		J124-1	N/C	
J113-1	BRN-BLK	Solenoid #9 drive to playfield coil	J124-2	N/C	
J113-2	KEY		J124-3	KEY	
J113-3	BRN-RED	Solenoid #10 drive to playfield coil	J124-4	N/C	
J113-4	BRN-ORG	Solenoid #11 drive to playfield coil	J124-5	N/C	
J113-5	BRN-YEL	Solenoid #12 drive to playfield coil	J124-6	N/C	
J113-6	BRN-GRN	Solenoid #13 drive to playfield coil	J124-7	RED-BLU	Lamp row #6 to coin door board J3-9
J113-7	BRN-BLU	Solenoid #14 drive to playfield coil	J124-8	RED-VIO	Lamp row #7 to coin door board J3-10
J113-8	BRN-VIO	Solenoid #15 drive to playfield coil	J124-9	RED-GRY	Lamp row #8 to coin door board J3-11
J113-9	BRN-GRY	Solenoid #16 drive to playfield coil	J125-1	RED-BRN	Lamp row #1 to playfield.
J114	NOT USED		J125-2	RED-BLK	Lamp row #2 to playfield.
J115	NOT USED		J125-3	KEY	
J116-1	VIO-BRN	Solenoid #1 drive to playfield coil	J125-4	RED-ORG	Lamp row #3 to playfield
J116-2	VIO-RED	Solenoid #2 drive to playfield coil	J125-5	RED-YEL	Lamp row #4 to playfield
J116-3	KEY		J125-6	RED-GRN	Lamp row #5 to playfield
J116-4	VIO-ORG	Solenoid #3 drive to playfield coil	J125-7	RED-BLU	Lamp row #6 to playfield
J116-5	N/C		J125-8	RED-VIO	Lamp row #7 to playfield
J116-6	VIO-GRN	Solenoid #5 drive to playfield coil	J125-9	RED-GRY	Lamp row #8 to playfield
J116-7	VIO-BLU	Solenoid #6 drive to playfield coil	J126	NOT USED	
J116-8	VIO-BLK	Solenoid #7 drive to playfield coil	J127-1	WHT-GRN	9.8VAC from transformer secondary.
J116-9	VIO-GRY	Solenoid #8 drive to playfield coil	J127-2	WHT-GRN	9.8VAC loop from J127-1.
J117	NOT USED		J127-3	WHT-GRN	9.8VAC from transformer secondary.
J118	NOT USED		J127-4	KEY	
			J127-5	WHT-GRN	9.8VAC loop from J127-3.

Power Driver Board Continued...

J128-1	WHT-RED	16VAC loop from J128-2.
J128-2	WHT-RED	16VAC from transformer secondary.
J128-3	WHT-RED	16VAC loop from J128-4.
J128-4	WHT-RED	16VAC from transformer secondary.
J128-5	BLK-YEL	16VAC loop from J128-6.
J128-6	BLK-YEL	16VAC from transformer secondary.
J128-7	KEY	
J128-8	BLK-YEL	16VAC loop from J128-9.
J128-9	BLK-YEL	16VAC from transformer secondary.
J129-1	RED	9VAC from transformer secondary.
J129-2	RED	9VAC from transformer secondary.
J129-3	KEY	
J129-4	BLU-WHT	13VAC from transformer secondary.
J129-5	BLU-WHT	13VAC loop from J129-4.
J129-6	BLU-WHT	13VAC from transformer secondary.
J129-7	BLU-WHT	13VAC loop from J129-6.
J130	NOT USED	
J131	NOT USED	
J132	NOT USED	
J133-1	N/C	
J133-2	RED-BRN	+50V to coils.
J133-3	RED-BLK	+50V to coils.
J133-4	KEY	
J133-5	N/C	
J133-6	RED-WHT	+20V to playfield flashers.
J134-1	N/C	
J134-2	N/C	
J134-3	N/C	
J134-4	KEY	
J134-5	RED-WHT	+20V to insert panel flashers.
J135	NOT USED	
J136	NOT USED	
J137	NOT USED	
J138	NOT USED	
J139-1	KEY	
J139-2	GRY-YEL	+12V to Coin Door board J2-2.
J139-3	BLK	Ground to Coin Door board J2-1.
J139-4	N/C	
J139-5	BLK-WHT	Signal for coin meter to coin door brd J2-7.
J140-1	KEY	
J140-2	GRY-YEL	+Motor EMI Boards
J140-3	N/C	
J140-4	N/C	
J141-1	KEY	
J141-2	GRY-YEL	+12V to 10-Opto board, Auto Adjust Eddy Sensor boards, Defender Switch board, and DC Motor Control board
J141-3	BLK	Ground to 10-Opto board, Auto Adjust Eddy Sensor boards, Defender Switch board, and DC Motor Control board
J141-4	N/C	

LAMP MATRIX

		Yellow (B+)						Red	
Column		1 Yellow-Brown J121-1 Q96	2 Yellow-Red J121-2 Q100	3 Yellow-Orange J121-3 Q95	4 Yellow-Black J121-4 Q99	5 Yellow-Green J121-5 Q94	6 Yellow-Blue J121-6 Q98	7 Yellow-Violet J121-7 Q93	8 Yellow-Gray J121-9 Q97
Row									
1	Red-Brown J125-1 Q104	MONSTER MOSH PIT 11	RIGHT RAMP ARROW 21	QUARTER MOOM (2) 31	LEFT RETURN 41	GUITAR 51	CREATURE 61	LEFT FRANK ARM 71	MUCK 81
2	Red-Black J125-2 Q108	HALF MOON (2) 12	ROCK C.D. 22	LEFT BLUE TARGET 32	LEFT OUTLANE 42	DRUMS 52	BRIDE 62	LEFT FRANK LEG 72	SEAWEED 82
3	Red-Orange J125-4 Q103	FRANK ARROW 13	RIGHT RETURN 23	TOMB TREASURE 33	THREE-QUARTERS MOON (2) 43	BASS GUITAR 53	FRANKENSTEIN 63	FRANK TORSO 73	ALGAE 83
4	Red-Yellow J125-5 Q107	DRAC - ATTACK 14	FULL MOON FEVER (2) 24	DRACULA STANDUP TOP 34	RIGHT BLUE TARGET 44	KEYBOARD 54	MUMMY 64	FRANK HEAD 74	POND SCUM 84
5	Red-Green J125-6 Q102	EXTRA BALL 15	RIGHT GARGLE 25	RIGHT TOP LANE 35	LEFT RAMP ARROW 45	MICROPHONE 55	WOLFMAN 65	RIGHT FRANK LEG 75	CENTER LOOP ARROW 2 85
6	Red-Blue J125-7 Q106	MONSTERS OF ROCK 16	RIGHT WARM UP 26	CENTER TOP LANE 36	LEFT PRIMP 46	SAXOPHONE 56	DRACULA 66	RIGHT FRANK ARM 76	CENTER LOOP ARROW 1 86
7	Red-Violet J125-8 Q101	MONSTER BASH 17	RIGHT PRIMP 27	LEFT TOP LANE 37	LEFT WARM UP 47	CENTER LOOP ARROW 3 57	RIGHT OUTLANE 67	LEFT LOOP ARROW 77	LAUNCH BUTTON 87
8	Red-Gray J125-9 Q105	MUMMY MAYHEM 18	RIGHT LOOP ARROW 28	DRACULA STANDUP BOTTOM 38	LEFT GARGOYLE 48	CENTER BLUE TARGET 58	SHOOT AGAIN 68	NOT USED 78	START BUTTON 88

J1XX = Power Driver Board

SWITCH MATRIX

		White								Green	
DEDICATED GROUNDED SWITCHES	Column	1 Green-Brown J206-1 U20-18	2 Green-Red J206-2 U20-17	3 Green-Orange J206-3 U20-16	4 Green-White J206-4 U20-15	5 Green-Black J206-5 U20-14	6 Green-Blue J206-6 U20-13	7 Green-Violet J206-7 U20-12	8 Green-Gray J206-9 U20-11	FLIPPER GROUNDED SWITCHES	
	Row										
Orange-Brown J205-1 LEFT COIN CHUTE U17-5 D1	1 White-Brown J208-1 U18-11	LAUNCH BUTTON 11	SLAM TILT 21	TROUGH EJECT 31	NOT USED 41	LEFT SLINGSHOT 51	LEFT LOOP LOW 61	RIGHT RAMP ENTER 71	UP/DOWN BANK UP 81	BLACK-GREEN J208-13 LOWER RIGHT FLIPPER E.O.S. F1	
Orange-Red J205-2 CENTER COIN CHUTE U17-7 D2	2 White-Red J208-2 U18-9	DRACULA STANDUP TOP 12	COIN DOOR CLOSED 22	TROUGH BALL 1 32	LEFT FLIPPER OPTO 42	RIGHT SLINGSHOT 52	LEFT LOOP HIGH 62	RIGHT RAMP EXIT 72	UP/DOWN BANK DOWN 82	BLUE-VIOLET J212-12 LOWER RIGHT FLIPPER OPTO F2	
Orange-Black J205-3 RIGHT COIN CHUTE U17-11 D3	3 White-Orange J208-3 U18-5	START BUTTON 13	TOMB TREASURE 23	TROUGH BALL 2 33	RIGHT FLIPPER OPTO 43	LEFT JET BUMPER 53	RIGHT LOOP LOW 63	RIGHT RAMP LOCK 73	FRANK TABLE DOWN 83	BLACK-BLUE J208-12 LOWER LEFT FLIPPER E.O.S. F3	
Orange-Yellow J205-4 4TH COIN CHUTE U17-9 D4	4 White-Yellow J208-4 U18-7	PLUMB BOB TILT 14	ALWAYS CLOSED 24	TROUGH BALL 3 34	LEFT BLUE TARGET 44	RIGHT JET BUMPER 54	RIGHT LOOP HIGH 64	DRACULA POSITION 5 74	FRANK TABLE UP 84	BLUE-GRAY J212-11 LOWER LEFT FLIPPER OPTO F4	
Orange-Green J205-6 U16-9 Normal Function Test Function Srv Crdts Escape D5	5 White-Green J208-5 U19-11	DRACULA STANDUP BOTTOM 15	DRACULA TARGET 25	TROUGH BALL 4 35	CENTER BLUE TARGET 45	BOTTOM JET BUMPER 55	CENTER LOOP 65	DRACULA POSITION 4 75	LEFT UP/DOWN BANK TARGET 85	BLACK-VIOLET J208-11 UPPER RIGHT FLIPPER E.O.S. F5	
Orange-Blue J205-7 U16-11 Normal Function Test Function Volume Dn Down D6	6 White-Blue J208-7 U19-9	LEFT OUTLANE 16	LEFT RETURN LANE 26	RIGHT POPPER 36	RIGHT BLUE TARGET 46	LEFT TOP LANE 56	LEFT RAMP ENTER 66	DRACULA POSITION 3 76	RIGHT UP/DOWN BANK TARGET 86	BLACK-YELLOW J212-10 UPPER RIGHT FLIPPER OPTO F6	
Orange-Violet J205-8 U16-7 Normal Function Test Function Volume Up Up D7	7 White-Violet J208-8 U19-5	RIGHT RETURN LANE 17	RIGHT OUTLANE 27	NOT USED 37	LEFT FLIPPER PROXIMITY SENSOR 47	CENTER TOP LANE 57	LEFT RAMP EXIT 67	DRACULA POSITION 2 77	FRANK HIT 87	BLACK-GRAY J208-10 CENTER SPINNER F7	
Orange-Gray J205-9 U16-5 Normal Function Test Function Begin Test Enter D8	8 White-Gray J208-9 U19-7	SHOOTER LANE 18	LEFT EJECT 28	NOT USED 38	RIGHT FLIPPER PROXIMITY SENSOR 48	RIGHT TOP LANE 58	CENTER RAMP ENTER 68	DRACULA POSITION 1 78	NOT USED 88	BLACK-BLUE J212-9 UPPER LEFT FLIPPER OPTO F8	

J2XX = CPU BOARD

= OPTO, TYPICALLY CLOSED

WARNINGS & NOTICES

WARNING

FOR SAFETY AND RELIABILITY, substitute parts and equipment modifications are not recommended. Use of Non-WILLIAMS parts or modifications of game circuitry, may adversely affect game play, or may cause injuries.

SUBSTITUTE PART OR EQUIPMENT MODIFICATIONS may void FCC/CANADA Type Acceptance.

BECAUSE THIS GAME IS PROTECTED by Federal copyright, trademark, and patent laws, unauthorized game conversions may be illegal under Federal law.

THIS 'CONVERSION' PRINCIPLE ALSO APPLIES to unauthorized facsimiles of WILLIAMS equipment, logos, designs, publications, assemblies, and games (or game features not deemed to be public domain), whether manufactured with WILLIAMS components or not.

NOTICE

WILLIAMS, Lane-change and Multi-ball are trademarks of WILLIAMS ELECTRONICS GAMES, INC. Entire contents of this manual © 1998 WILLIAMS ELECTRONICS GAMES, INC.

WARNING

NOTE: This equipment has been tested and found to comply with the limits for a Class A digital device, pursuant to Part 15 of the FCC Rules. These limits are designed to provide reasonable protection against harmful interference when the equipment is operated in a commercial environment. This equipment generated, uses, and can radiate radio frequency energy and if not installed and used in accordance with the instruction manual, may cause harmful interference to radio communications. Operation of this equipment in a residential area is likely to cause harmful interference in which case the user will be required to correct the interference at his own expense.

This Class B digital apparatus meets all requirements of the Canadian Interference-Causing Equipment Regulations.

Cet appareil numérique de la classe B respecte toutes les exigences du Règlement sur le matériel brouilleur du Canada.

RF Interference Notice

CABLE HARNESS PLACEMENTS and ground strap routing on this game have been designed to keep RF radiation and conduction within levels accepted by the FCC Rules.

TO MAINTAIN THESE LEVELS, reposition harnesses and reconnect ground straps to their original placements, if they become disconnected during maintenance.

FCC/CANADA STICKER. Check the back of your game to verify that an FCC/CANADA certification sticker was attached to your game at the factory. All games that leave the WILLIAMS plant have been tested and found to comply with FCC/CANADA Rules. Because the sticker is proof of this fact, legal repercussions to the owner and distributor may result, if the sticker is missing. If you receive a game that has no FCC/CANADA sticker, call WILLIAMS for advice or write us a note on your Game Registration Card. Be sure that the card bears your game's serial number.

For Service...
Call your authorized Williams Distributor

Williams Electronics Games, Inc.
3401 N. California Avenue
Chicago, IL 60618

© 1998 Williams Electronics Games, Inc. All Rights Reserved.

***CAUTION: Transport this game ONLY
With the hinged backbox DOWN!***