

# FREEBEE

**PART NO.  
420-0199**

MANUFACTURED BY



# OWNER'S MANUAL

GEE BEE  
OPERATING INSTRUCTIONS  
AND  
SERVICE MANUAL

GEE BEE OWNER'S MANUAL

Copyright © 1979 by GREMLIN INDUSTRIES, INC. All Rights Reserved  
All the information contained herein is the exclusive proprietary property  
of GREMLIN INDUSTRIES, and is disclosed in confidence and may not be  
duplicated nor copied in whole or part nor be used for any purposes other  
than that for which disclosed.

## TABLE OF CONTENTS

	PAGE
INTRODUCTION	1
IMPORTANT NOTE	2
REPACKAGING INSTRUCTIONS	3
REPLACEMENT PARTS LIST	4
TRANSFORMER VOLTAGE CONVERSION	6
GAME CONCEPT AND OPERATION	7
ADJUSTMENTS AND OPTIONS	10
MAINTENANCE AND TROUBLESHOOTING PROCEDURES	12
SCHEMATICS	Following Pages

## INTRODUCTION

This is an electronic game that makes extensive use of digital integrated circuitry and television monitor circuitry. This manual assumes the maintenance technician possesses a general knowledge of solid state circuitry, microprocessor, TTL digital integrated circuitry and T.V. monitor concepts. Any individual NOT knowledgeable in these areas SHOULD NOT attempt repair of the electronic portion of this game. IT SHOULD BE NOTED THAT ANY ATTEMPT TO REPAIR THE GAME IN THE FIELD WITHOUT EXPRESS CONSENT OF THE FACTORY WILL IMMEDIATELY VOID THE WARRANTY!!!

### IMPORTANT NOTES:

- NEVER           replace any components with anything other than exact replacement parts. (See Parts List located on Service Schematics.
  
- NEVER           remove circuit boards/connections while power is on.
  
- DO NOT          replace the fuse with anything other than the proper value. A blown fuse indicates an overload condition within the game. Replacing the fuse with a higher value can cause severe damage to internal components if an overload occurs.
  
- ALWAYS          consult the manual before attempting repairs.
  
- CORRESPONDENCE   regarding this game should be addressed to:

GREMLIN INDUSTRIES, INC.

8401 Aero Drive

San Diego, California 92123

(714) 277-8700

### IMPORTANT NOTE

An important service note is posted in this game and is repeated here for emphasis:

IF AT ANY TIME THE T. V. SCREEN SHOWS A MEANINGLESS DISPLAY  
OR THE GAME OTHERWISE MALFUNCTIONS, SIMPLY DROP A COIN INTO  
THE COIN MECHANISM. THIS SHOULD CORRECT THE PROBLEM. IF  
NOT, THE GAME REQUIRES SERVICE.

The circuitry in this game has been arranged so that the insertion of a quarter through the coin mechanism will reset the system. This clears up temporary problems caused by power line disturbances, static, etc.

#### SERVICE TECHNICIAN NOTE:

The system reset circuitry described above requires that the coin counter is attached to the system. If there is a coin counter problem and no replacement is available, the game will function properly if a 10K Ohm resistor is connected across the coin counter input pins to the video logic board.

## REPACKAGING INSTRUCTIONS

Should it be necessary to ship this game, follow the instructions below for game recrating:

- A) If the original shipping bolts have been discarded (Ref.1), obtain four 5/16-18x1 3/4" hex head bolts with 5/16" flat washers. Carefully lay the game on its side and attach skid (Ref.2).
- B) Place game upright. Tape game keys to upper flange of operator's panel (Ref.3). Crate the game using appropriate shock-absorbent packing material (Ref.4). Include padding on all four corners of the game (Ref.5). After crating is completed, secure package with strapping (Ref.6).

NOTE: If the game is to be shipped to GREMLIN for service or repair, attach a tag identifying the distributor and indicate the service or repair to be made; include the full serial number of the game. GAME MUST BE SHIPPED PREPAID.

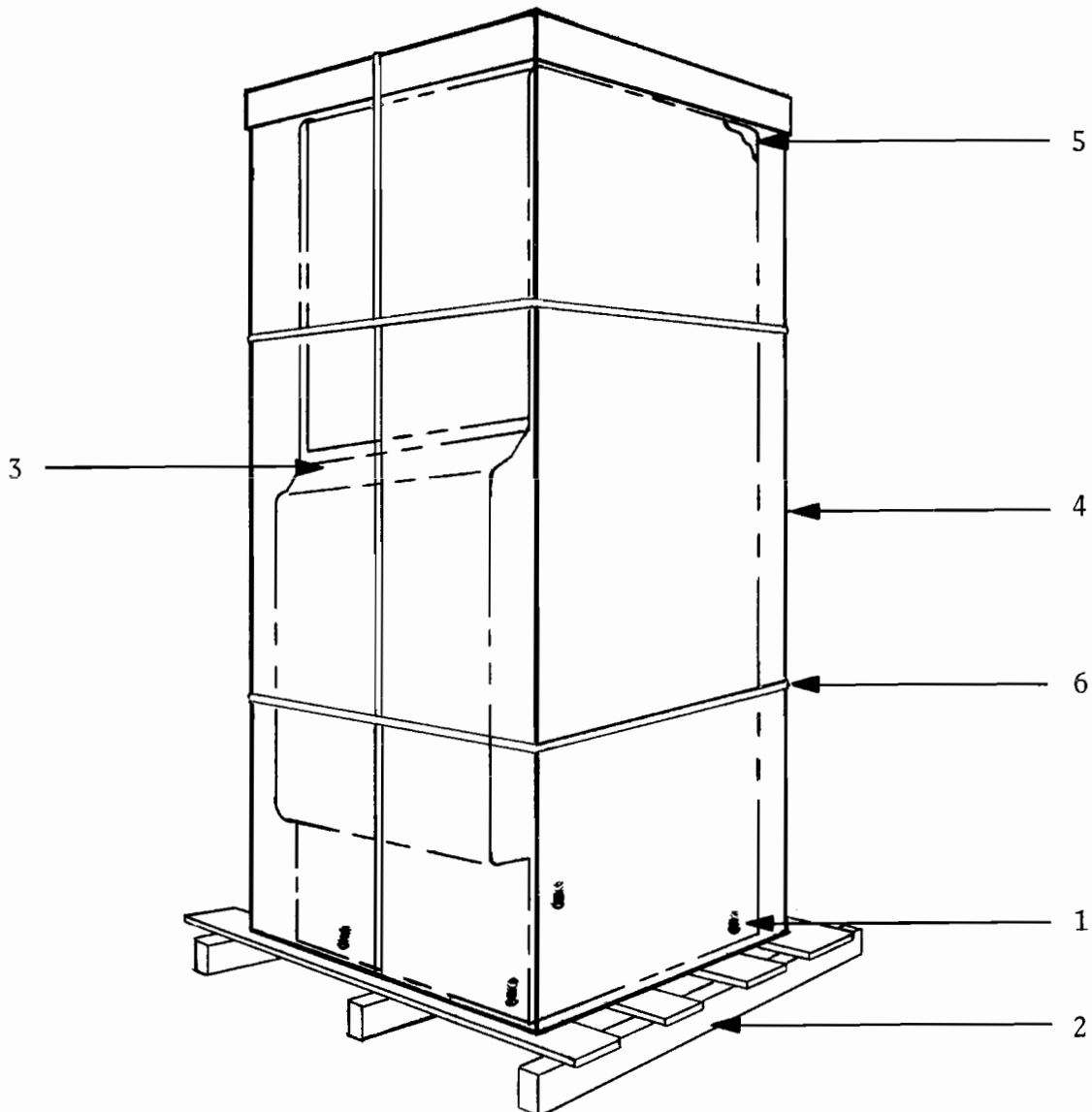

## REPLACEMENT PARTS LIST- GEE BEE

### 1. LOGIC BOARD PARTS

GREMLIN PART NUMBER	DESCRIPTION
211-0050	44 PIN EDGE CONNECTOR
230-0023	CRYSTAL, 18.432 MHZ
313-0002	LM311N IC
313-0003	LM340 T5 7805(+5 VOLT REGULATOR)
313-0006	LM380
313-0014	LM340 T12 (+12 VOLT REGULATOR)
313-0023	LM320 T5 (-5 VOLT REGULATOR)
315-0018	2111 RAM IC
315-0019	EPROM 2708 IC
315-0046	2114/2114L RAM IC
316-0137	PROM IC 2332
510-0043	6 POSITION DIP SLIDE SWITCH
530-0008	HEATSINK

### 2. POWER SUPPLY

211-0042	CONNECTOR SOCKET
211-0045	CONNECTOR PLUG
560-0003	TRANSFORMER, GAME

### 3. CONTROL PANEL

250-0068	BRACKET (FOR VOLUME CONTROL)
250-0328	BEZEL FOR SERVE SWITCH, TAPERED
240-0092	KNOB FOR PADDLE CONTROL
475-0007	10K POT, VOLUME CONTROL
475-0016	5K POT, PADDLE CONTROL
510-0014	SLIDE SWITCH (ON BRACKET W/VOLUME)
510-0045	SERVE SWITCH, ILLUMINATED (W/BULB)
510-0046	PLAYER 1 START SWITCH (W/ BULB) LEFT
510-0047	PLAYER 2 START SWITCH (W/ BULB) RIGHT

### 4. COIN MECHANISM

220-0071	COIN REJECT BUTTON W/ SPRING
220-0072	COIN RETURN STOP (U-BOLT W/NUTS)
220-0074	COIN MECHANISM W/LOCKOUT COIL (U.S.B.)
	COIN LOCKOUT COIL

5. MISCELLANEOUS PARTS

130-0001

GAME SPEAKER

200-0009

WELLS GARDNER MONITOR B/W

220-0035

CABINET LOCK

420-0158

MANUAL, WELLS GARDNER MONITOR

420-0199

MANUAL, GEE BEE GAME



## GEE BEE TRANSFORMER VOLTAGE CONVERSION

TO CONVERT THE GAME TRANSFORMER (PART NO. 560-0003) TO 100, 115, OR 230 VAC, REFER TO THE FOLLOWING CHART:

FOR 100 VOLTS: CONNECT THE VOLTAGE INPUT LINES TO PINS 1 AND 2 ON THE XFMR.

FOR 115 VOLTS: CONNECT THE VOLTAGE INPUT LINES TO PINS 1 AND 3.

FOR 230 VOLTS: CONNECT THE VOLTAGE INPUT LINES TO PINS 1 AND 4, WITH PIN 3 CONNECTED TO THE LAMP CIRCUIT.

#### GAME CONCEPT:

GEE BEE is a unique one or two player ball and paddle video game. By controlling a set of paddles, players keep a ball bouncing around the screen to knock out point blocks for high score. There are also bumpers, rollovers and a spinner to aim for, all worth more points. The game accepts up to 9 credits, and each game plays either 3 or 5 balls, depending on which option is set.

#### GAME START:

When one credit is accepted, the screen displays the number, and only the one-player start button flashes. When two or more credits (up to 9) are displayed, both the one- and two- player start buttons flash. The game is adjustable for the number of coins per credit. (See Adjustments and Options)

#### GAME PLAY:

If the one-player start button is pushed, the credits count down one; when the two-player button is pushed, the credits decrease by two. Then, the SERVE button flashes and, when pushed, releases the ball onto the playfield. The ball automatically appears after 10 seconds if the serve button is not pushed.

For two-players, GEE BEE features alternate play; that is, when the first player's turn is over, the game resets to allow player two to take his turn. As the alternate action continues, the game remembers each player's score.

The paddle knob causes both paddles to move to the left and right across the screen. The ball bounces off the top side of both paddles, but passes through the upper paddle's bottom side. The ball speed varies, depending on the number of hits made for that turn. When first served, the ball moves at slow speed, then changes to medium speed after the 4th hit with the paddles. On the 8th hit, the ball speed becomes fast. When the high speed ball passes through the spinner, its speed changes to slow, then to medium after the first hit.

## SCORING:

There are three kinds of point blocks- top blocks, side blocks, and pocket blocks. When the ball hits a block, that block is erased and the points are added to the score. The point values for the blocks are as follows:

### TOP BLOCKS AND LEFT AND RIGHT SIDE BLOCKS:

Row A (outermost row)	1 block = 20 points/1 Bonus (1000 points) for erasing one row.
Row B	1 block = 50 points/1 Bonus (1000 points) for erasing one row.
Row C	1 block = 100 points/1 Bonus (1000 points) for erasing one row.

The points for the left and right pocket blocks are 100, 300, 500, 700, and 900 points, respectively, starting from the bottom of the pocket.

GEE BEE has two bumpers at the top of the screen, which give 10 points when hit. They enlarge momentarily when hit, then return to normal size. When one bank of side blocks is erased, the bumper on that side increases to 100 points. There is also a spinner between the bumpers, which gives points depending on how many times it spins. At slow ball speed, the spinner turns twice; at medium speed, it spins 4 times; and, at fast speed, it spins 6 times. The spinner is normally gray in color, but changes to white when all the top blocks are erased. One revolution is worth 10 points when the spinner is gray, and worth 100 points when it is white.

Five rollovers (circled G's) appear at the bottom of the screen, and are colored gray normally. Each circle changes from gray to white, or white to gray, when a ball passes through it. The change from gray to white is worth 50 points. If all 5 rollovers change to white, the bonus multiplier display becomes X2, and doubles the score for that turn. No further changes occur after all rollovers become white in one turn.

GEE BEE provides a safety gate to prevent the ball from leaving the playfield through either the left or right side exits. The left or right safety gate comes on when all the left or right side blocks, respectively, are knocked out. When the ball hits the safety gate once, the ball rebounds, the safety gate disappears and 500 points plus 1 bonus (1000 points) are added to the score. If the ball leaves the playfield through one of the side exits (no safety gate) 500 points plus the bonus are added to the score.

## SCORING (Continued)

Special features in the game include a chance for an extra ball if all left or right pocket blocks are erased. Then, a flashing "EXTRA BALL CHANCE" arrow appears in the playfield exit on the side with the empty pocket. If the ball leaves through the exit where the arrow is flashing, a "SAME PLAYER SHOOTS AGAIN" sign appears and one extra ball is awarded. If a safety gate is displayed in that exit, along with the extra ball signal, the ball is rebounded and an extra ball is awarded. Only one extra ball is given per turn. A free credit is given when all left AND right pocket blocks are erased. In addition, the game gives one free credit if the player's score exceeds a preselectable number. (See Adjustments and Options) The maximum score attainable is 999990; the maximum bonus points are 99000. Finally, GEE BEE produces a number of sounds that vary depending on whether the ball hits a wall, a block, or the paddles.

## ADJUSTMENTS AND OPTIONS:

### 1. SELF TEST

GEE BEE has a built-in self test, which enables the owner to check the game for proper operation quickly. By turning on the slide switch inside the coin door, the game runs through the following test:

Self test switch ON:

1. The ball moves diagonally from the lower left corner to the upper right corner of the screen without disappearing. This indicates normal operation.
2. When the ball reaches the upper right corner, the screen displays the following information:

OK or NG	For game OK, or NG for a malfunction.
2A	Test value of paddle knob - these digits change successively when the paddle knob is turned to the left or right. With the paddles turned to the right, the display indicates a number between 0 and 16. Any number BELOW 10 means normal operation.  When the paddles are turned all the way to the left, the display counts 0...1...2...3...4...5...6...7...8...9...A...B...C...D...E...F...10.... If the value is ABOVE A0, but BELOW FF, the game is functioning normally.*
U or T	Indicates whether the game is an upright or table model.
3 or 5	Indicates the number of serve balls per game.
A,B,C, or F	For charge per game (see Chart, following).
04	For replay points (see Chart, following).

\* A note on this numbering system: The values A-F represent the DECIMAL numbers 10-15. So, a display of A0 would be a higher value than, say, 70, 80, or 90, but LESS THAN B0, C0, D0, E0, or F0. In this numbering system (called HEXADECIMAL for 16 digits, 0-F, instead of 10 digits, 0-9, in decimal) the highest 2-digit number is FF.

ADJUSTMENTS AND OPTIONS (Continued)

3. If the serve button and the one- and two- player start buttons are lit during test, normal operation is indicated.
4. The game is functioning normally if the game sounds are heard when the serve button, the one- and two- player start buttons, and coin switch are each activated.
5. Turn the self-test switch OFF.
6. The lockout coil de-activates momentarily when the test switch is turned off. The coil re-activates instantly.
7. With the test switch off, the screen displays a cross-hatch pattern for about a second. If it is desired to use this pattern for monitor adjustments, simply turn the test switch on.
8. The game counter advances one step when the self-test is run once.

II. OTHER ADJUSTMENTS:

1. Volume control -- The volume can be adjusted with the control inside the coin door.
2. OPTIONS: (number of balls per game, game charge, and replay points)

The following is a chart of options for GEE BEE, all selectable by means of 6 small slide switches located on the logic board.

OPTION	SWITCH POSITION						SYMBOL	DETAILS
	1	2	3	4	5	6		
model type	on						U	upright table
	off						T	
number of serve balls		on					3	3 balls per game 5 balls " "
		off					5	
game charge			on	on			A	1 coin, 1 play 1 coin, 2 plays 2 coins, 1 play free game
			off	on			B	
			on	off			C	
			off	off			F	
credit level		on			on	on	00	1 credit up:      2 credits up:
		off			on	on	00	
		on			off	on	04	40000              80000
		off			off	on	06	60000              120000
		on			on	off	07	70000              140000
		off			on	off	10	100000             200000
		on			off	off	10	100000             200000
		off			off	off	15	150000             300000

## MAINTENANCE & TROUBLESHOOTING PROCEDURES:

Always check and confirm the following items when it is believed that trouble has occurred.

1. Is the power switch on?  
Forgetting to turn on the power switch is a comparatively common oversight.
2. Is the fuse intact?  
One fuse is provided on the power supply board and on the monitor board. If a fuse blows out after being replaced, it indicates trouble in another component. Always replace with the prescribed capacity fuse, as normal equipment may be damaged if larger fuses are used as a substitute.
3. Are the connectors firmly inserted?  
Poor connector connections must be considered for any trouble indication. Check all related connectors for poor contact. Although disconnected connectors are easily spotted, poor contacts are difficult to locate. The connectors should therefore be pushed in firmly and then loosened to spot poor connections. When testing the PC board connectors, always turn off the power supply. Care should also be taken in relation to the power supply on the other connectors.
4. Turn power supply off and on again.  
As the unit may return to normal if the control circuit is reset when the game seems abnormal, turn the power off and on to see if the trouble will clear up.
5. Are there any metallic objects on the PC board?  
Ensure that there are no metallic objects on the PC board, as this will be the cause of shorts. Also, refrain from putting any other objects inside the cabinet.
6. Care in circuit conductivity tests.  
When testing conductivity of the circuit with a tester, always disconnect PC board edge connector J2.

The following flow charts are printed here for a logical, step-by-step approach to trouble-shooting the game, should that be necessary.

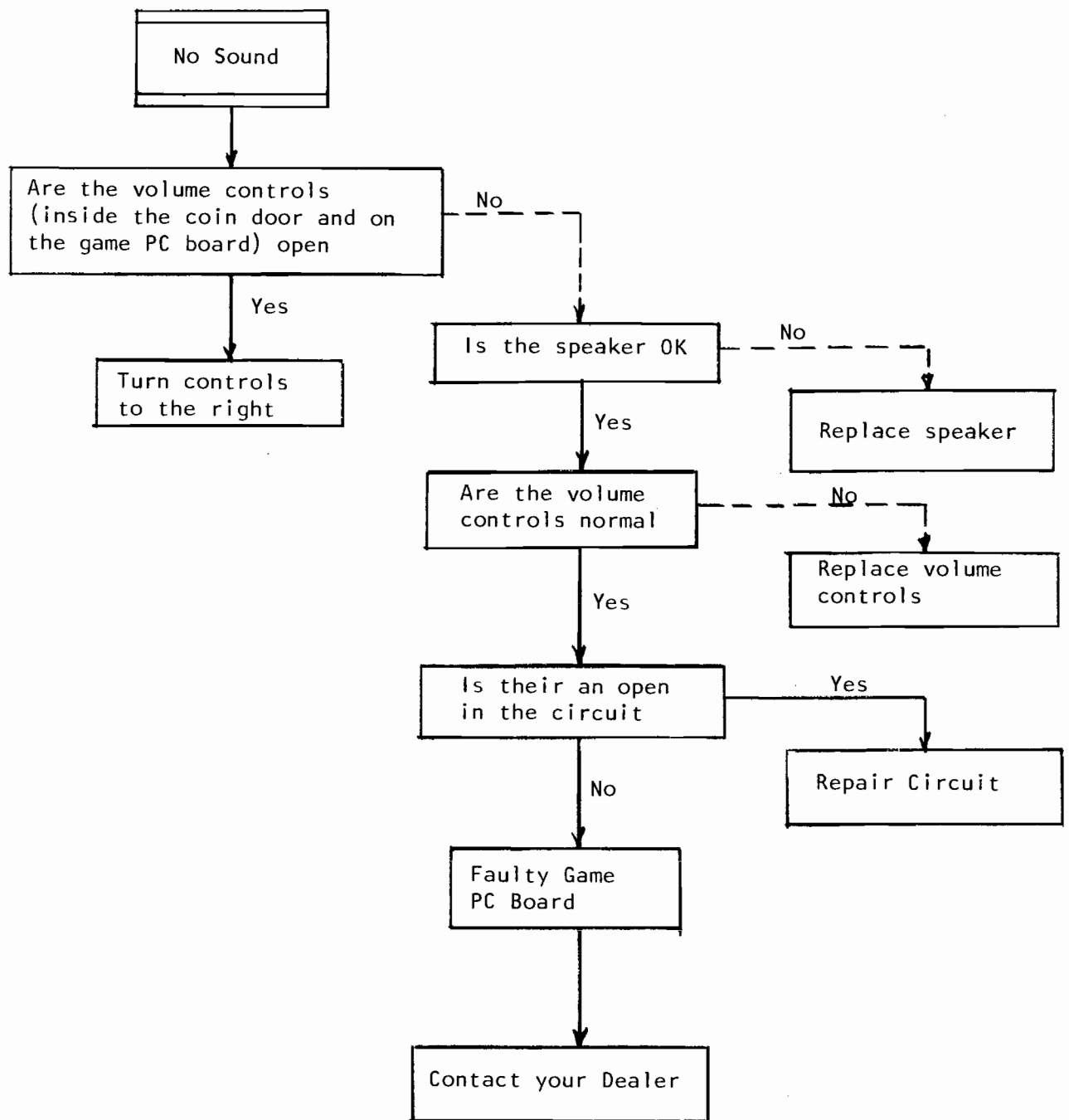



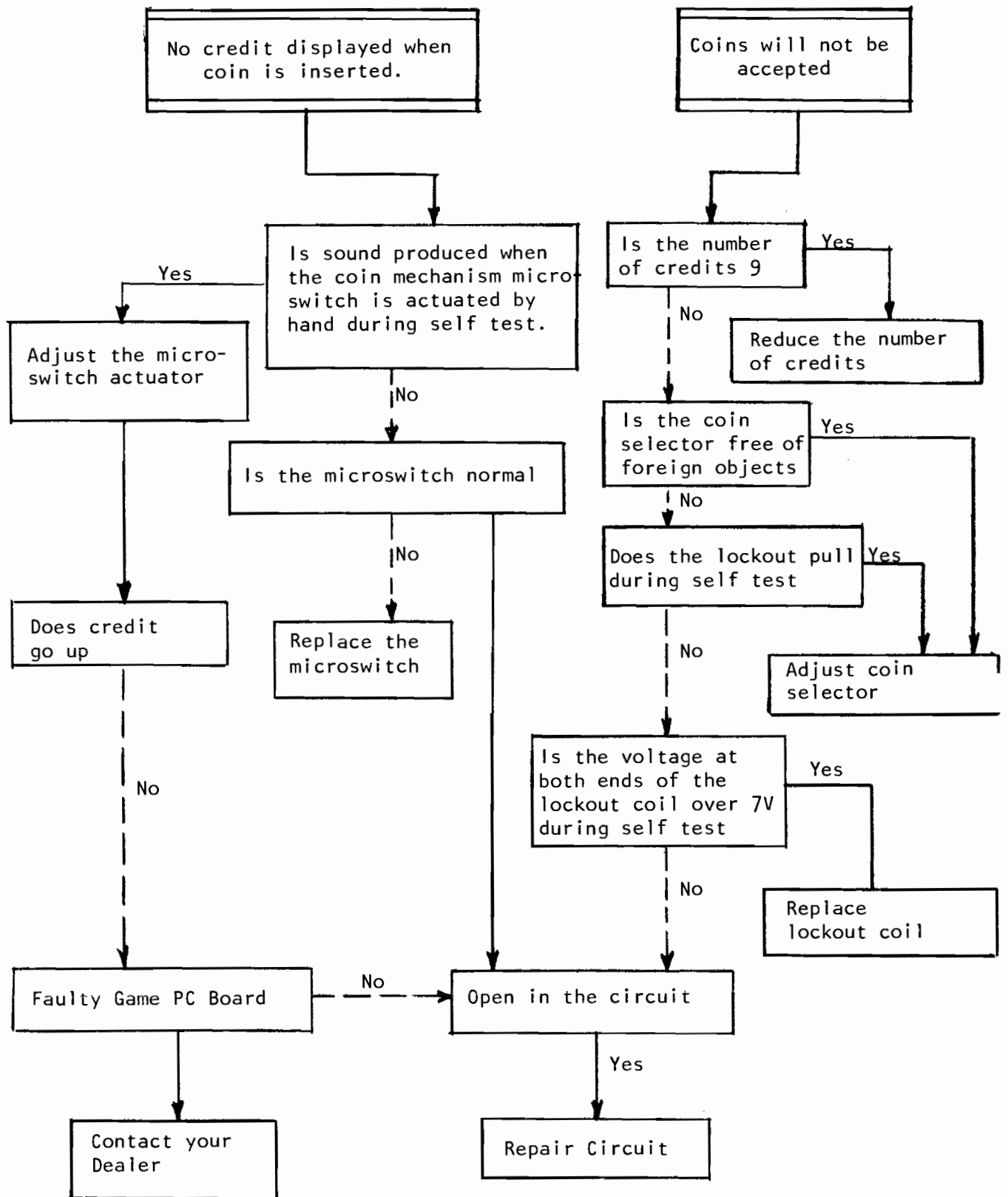

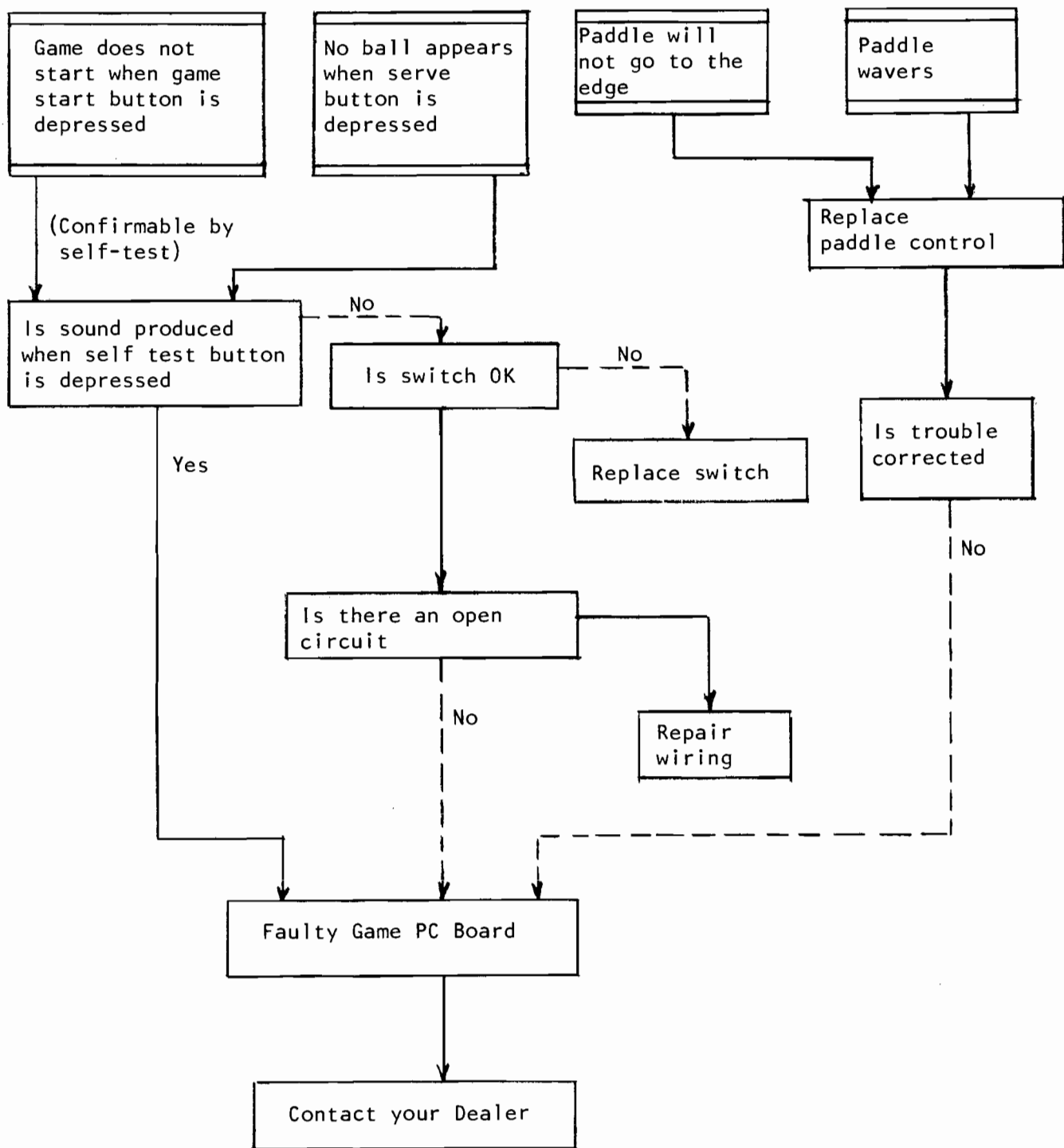

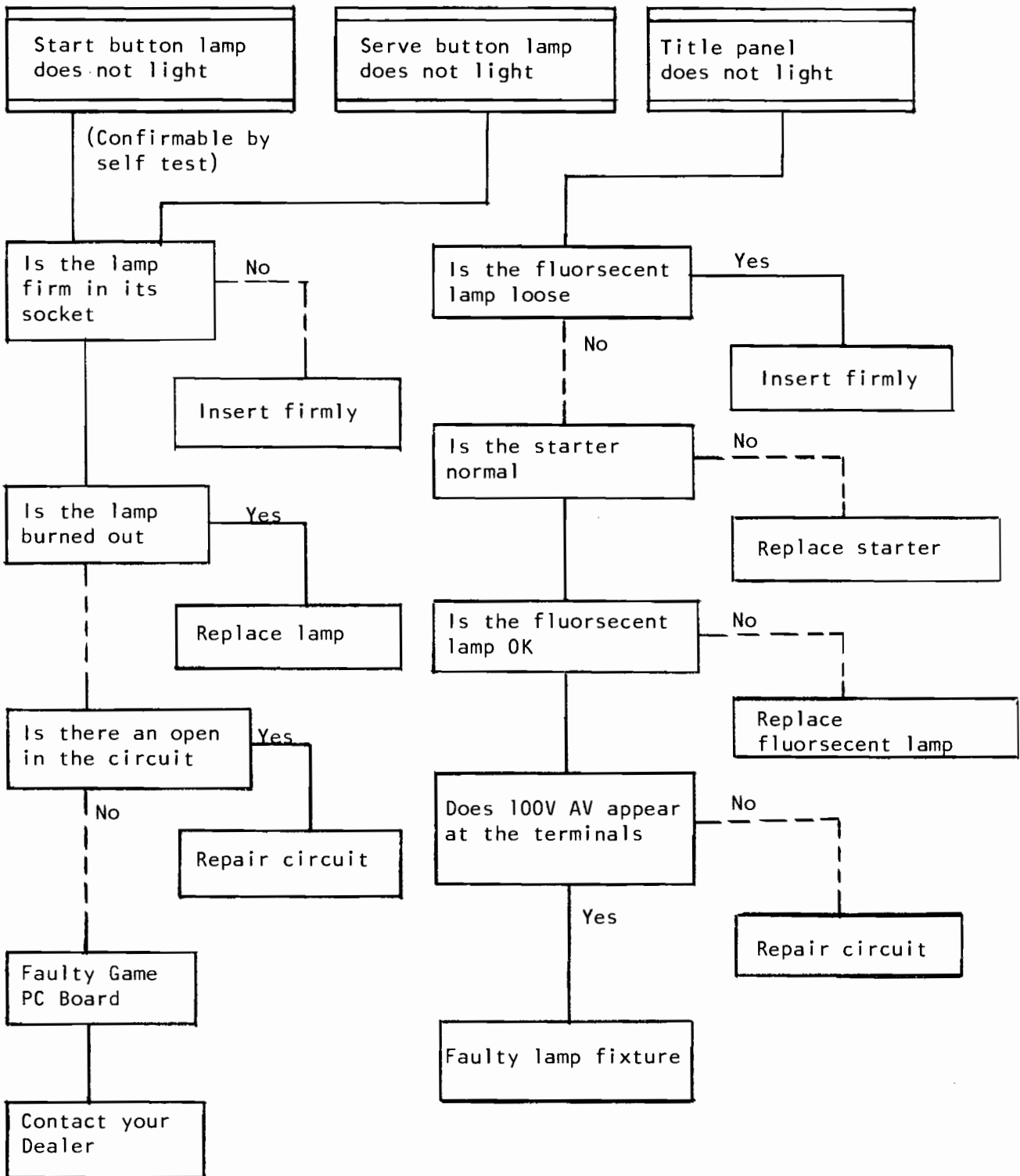

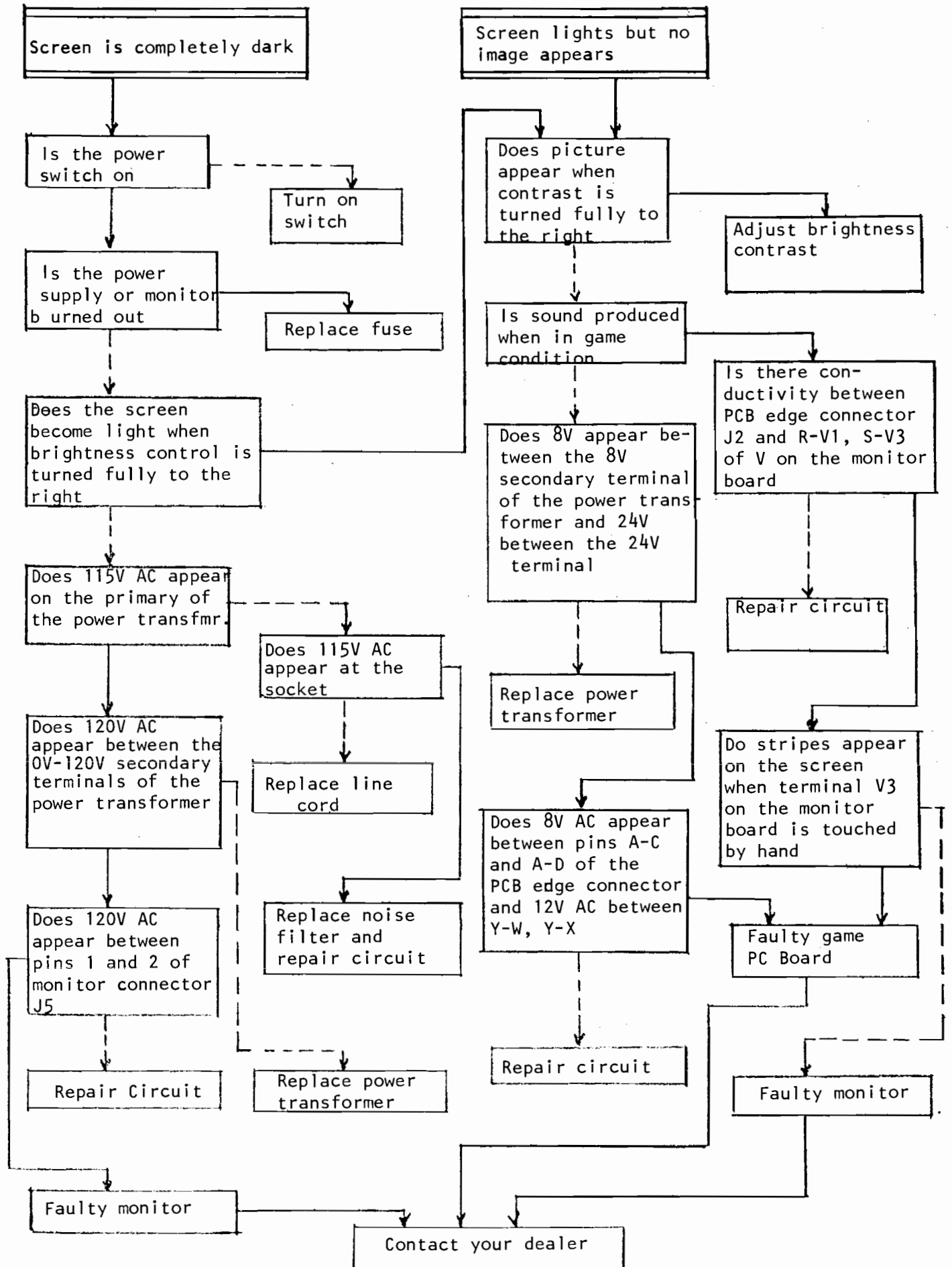

**Gremlin Industries, Inc.**  
San Diego, California 92123

**PARTS LIST**

**TITLE**  
TOP ASSEMBLY GEE-BEE

725-0002  
DWG NO

SH 1  
OF 9

A  
REV

SEE FOUR 'D' SIZE SHTS

DRAWN G. WOOD.  
CHECK *[Signature]* 1-22-79

ENGR  
APPR

LTR DATE

REVISION DESCRIPTION

DRAFT

CHECK

APPR

A 1-17-79

INITIAL RELEASE

G. WOOD

*[Signature]*

*[Signature]*

**Gremlin Industries, Inc.**  
San Diego, California 92173

**PARTS LIST**

**TITLE**  
TOP ASSEMBLY GEE - BEE

725 - 0002  
DWG NO

SH %  
OF 9  
A  
REV

ITEM NO	PART NO	QTY PER ASSY		DESCRIPTION	REF DES
1	725 - 0002	1		TOP ASSY. GEE - BEE	
2	130 - 0001	1		SPKR. GAME	
3	130 - 0002	1		SPKR. COVER	
4	140 - 0021	1		COVER J - BOX	
5	140 - 0034	1		CABINET GEE - BEE	
6	200 - 0009	1		MON VIDEO 23"	
7	220 - 0035	1		FOOT LOCK	
8	220 - 0074	2		MECH COIN SINGLE	
9	250 - 0048	1		CLIP SWITCH	
10	250 - 0285	1		FR. CASH DR MOD.	
11	250 - 0318	2		BKRT ANGLE CRT.	
12	250 - 0319	1		BKRT FRONT CRT.	
13	250 - 0320	1		BKRT REAR CRT	
14	250 - 0321	2		BKRT SIDE CRT	
15	250 - 0322	2		BKRT PLAY FIELD	
16	250 - 0323	1		BKRT SCORE	
17	250 - 0324	1		BKRT RET PLEXI	
18	250 - 0325	2		BKRT CONTRAL PNL.	
19	252 - 0059	2		BKRT SPACER.	
20	253 - 0097	1		LOGO PNL	
21	253 - 0098	1		MONITOR PNL	
22	253 - 0099	1		PNL PLAYFIELD.	
23	250 - 0330	2		BKRT RETAINER LOGO	
24		1		PALET GEE - BEE	

**Gremilin Industries, Inc.**  
San Diego, California 92123

**PARTS LIST**

**TITLE**  
TOP ASSEMBLY GEE-BEE

725-0002  
DWG NO

SH 3  
OF 9

A  
REV

ITEM NO	PART NO	QTY PER ASSY				DESCRIPTION	REF DES
25	280-0005	10				CABLE TIE	
26	280-0010	6				NUT WIDE	
27	220-0008	1				COUNTER DIGITAL	
28	390-0011	1				LAMP FLOR 18"	
29	390-0012	1				LAMP FIX FLOR 18"	
30	420-0028	1				DECAL S/N	
31	420-0030	1				DECAL CAUTION 115V	
32	420-0038	2				DECAL IMPORTANT NOTICE	
33	420-0040	1				DECAL RECYCLE	
34	420-0041	1				DECAL S/N SMALL	
35	420-0060	1				DECAL TIP N TELL	
36	420-0071	1				INST UNCRATING.	
37	420-0208	1				WRAP AROUND SIDE	
38	420-0209	1				TOP COVER.	
39	420-0124	4				CORNER STRIP.	
40	420-0198	1				SHADOW MASK.	
41	420-0199	1				MANUAL GEE - BEE	
42	420-0200	1				DECAL CARTON GEE - BEE	
43	420-0201	1				GRAPHIC SIDE LEFT	
44	420-0202	1				GRAPHIC SIDE RIGHT	
45	420-0207	1				DECAL SCORE	
46	420-0158	1				MANUAL W.G. 23 INCH	
47	250-0326	1				PLATE MTG XPMR.	
48							
49	807-0009	1				ASSY JUNCTION BOX.	

**Gremlin Industries, Inc.**  
San Diego, California 92173

**PARTS LIST**

**TITLE**  
TOP ASSEMBLY GEE - BEE

725 - 0002  
**DWG NO**

SH 4  
OF 9

A  
**REV**

ITEM NO	PART NO	QTY PER ASSY				DESCRIPTION	REF DES
50	825 - 0007	1				ASSEMBLY XEMR.	
51	825 - 0001	1				VIDEO LOGIC	
52	825 - 0002	1				CONTROL PNL	
53	825 - 0003	1				HARNNESS CONTROL PNL	
54	825 - 0004	1				HARNNESS SPEAKER	
55	825 - 0005	1				HARNNESS COIN MECH	
56	825 - 0006	1				HARNNESS, MAIN	
57	420 - 0204	1				COIN DECAL	
58	420 - 0205	1				PLAYER DECAL	
59		4				SCR. 1/4 - 20 x 1/2 HEX HD	
60		8				SCREW # 6 x 1/2 PAN HD XREC SHT MTL.	
61		6				SCREW # 10 x 1/2 PAN HD XREC SHT MTL.	
62		4				SCR. 10 - 24 x 1 PAN HD XREC	
63		4				SCR. 8 - 32 x 1 1/2 BND. HD XREC BLK OXIDE	
64		8				SCR. 10 - 24 x 1 1/2 CARTRIDGE	
65		3				SCREW # 6 x 3/8 PAN HD XREC. SHT MTL.	
66		2				SCR. 6 - 32 x 3/8 PAN HD XREC	
67		4				SCREW # 10 x 3/4 PAN HD XREC SHT MTL.	
68		2				SCR 10 - 24 x 1 CARTRIDGE	
69		2				SCR. 1/4 - 20 x 3/8 PAN HD XREC.	
70		2				SCR. 10 - 24 x 1/2 PAN HD XREC	
71		4				SCR 6 - 32 x 1/2 PAN HD XREC	
72		8				SCR 6 - 32 x 1/2 TRUSS HD TAMPER PROOF	
73		4				RIVET, POP 3/16 DIA. x 1/2	
74		4				NUT, HEX 1/4 - 20	





**Gremlin Industries, Inc.**  
San Diego, California 92123

**PARTS LIST**

**TITLE**  
ASSY VIDEO LOGIC  
G. B.

825-0001  
DWG NO

SH 1  
OF 9  
REV A

SHTS 6, 7, & 8 ARE "D" SIZE

**DRAWN** *W. J. B.* 12-18-78  
**CHECK** *Steve J. Fay*

ENGR  
APPR

**LTR** DATE

REVISION DESCRIPTION

**DRAFT**

**CHECK**

**APPR**

A 1-10-79

RELEASED

WJ B

*WJ B*

*WJ B*

**Greenham Industries, Inc.**  
San Diego, California 92121

**PARTS LIST**

**TITLE**  
ASSY VIDEO LOGIC  
G.B.

825-0001  
DWG NO

SH 5  
OF 9  
REV A

ITEM NO	PART NO	QTY PER ASSY			DESCRIPTION	REF DES
19	170-0157	1			PCB VID LOG G.B.	
20	211-0004	2			CONN PIN TEST PT	E1,E2
21	213-0001	6			SKT 24 PIN DUAL INLN	X1K,X3A,X1M,X1P,X1S,X1T
22	213-0005	1			SKT 40 PIN DUAL INLN	X1F
23	230-0023	1			XTAL 18.432 MHZ	1CY
24	313-0002	1			1C LM311C	6M
25	313-0003	1			1C 7805	1R3
26	313-0006	1			1C LM380	5K
27	313-0014	1			1C 7812	1R1
28	313-0023	1			1C 7905 C	1R2
29	314-0001	1			1C NE555	5L
30	314-0019	1			1C 74LS04	4P
31	314-0058	2			1C 74LS08	3M 4U
32	314-0059	2			1C 74LS10	3V 4H
33	314-0061	2			1C 74LS42	2V, 2T
34	314-0062	4			1C 74LS74	4E, 4F, 4N, 4T
35	314-0064	1			1C 74LS153	2M
36	314-0067	1			1C 74LS30	3N
37	314-0068	2			1C 74LS32	2U, 3U
38	314-0070	4			1C 74LS86	4J, 4K, 4L, 4M
39	314-0071	1			1C 74LS151	4R
40	314-0073	1			1C 74LS175	4S

Greenleaf Industries, Inc.  
San Diego, California 92161

**PARTS LIST**

**TITLE**  
ASSY VIDEO LOGIC  
G.B.

825-0001  
DWG NO

SH 2  
OF 9  
REV A

ITEM NO	PART NO	QTY PER ASSY			DESCRIPTION	REF DES
65	470-02R7	1			RES 2.7 OHM 1/4W 5%	R17
66	470-0332	1			RES 3.3K OHM 1/4W 5%	R31
67	470-0331	2			RES 330 OHM 1/4W 5%	R25, R26
68	470-0152	2			RES 1.5K OHM 1/4W 5%	R33, R34
69	470-0471	12			RES 470 OHM 1/4W 5%	R43-R48, R36, R56-R58, R60, R61
70	470-0472	6			RES 4.7K OHM 1/4W 5%	R18 - R23
71	470-0474	1			RES 470K OHM 1/4W 5%	R51
72	470-0912	1			RES 9.1K OHM 1/4W 5%	R52
73	481-0001	10			DIODE 1N4002	D2-D5, D11-D14, D16, D17
74	481-0006	6			DIODE 1N914 / 1N4148	D1, D6 - D10
75	482-0009	3			XSTR 2N5060	Q3 - Q5
76	482-0014	3			XSTR 2N4401	Q1 Q2 Q6
77	510-0043	1			SWITCH 6 POS DIP	SW 2
78	530-0008	1			HEAT SINK	
79	470-0105	1			RES 1M OHM 1/4W 5%	R54
80	470-0101	1			RES 100 OHM 1/4W 5%	R62
81	470-0682	1			RES 680 OHM 1/4W 5%	R32
82	316-0137	1			IC PROM 2332 G.B.	1K

**Gremlin Industries, Inc.**  
San Diego, California 92123

**PARTS LIST**

**TITLE**

MAIN HARDNESS GBS RES

825-0006  
DWG NO

SH 1  
OF 3  
REV A

SHT 3 IS "D" SIZE

**DRAWN**

G. LLOYD 12-28-78

**ENGR**

**APPR**

**LTR DATE**

A 1-10-79

**REVISION DESCRIPTION**

RELEASED

**DRAFT**

G.L.

**CHECK**

*[Signature]*

**APPR**

*[Signature]*



**Greenleaf Industries, Inc.**  
San Diego, California 92161

**PARTS LIST**

**TITLE**  
ASSY VIDEO LOGIC  
G. B.

825-0001  
DWG NO

SH 4  
OF 9  
REV A

ITEM NO	PART NO	QTY PER ASSY		DESCRIPTION	REF DES
41	314-0075	2		1C 74LS393	3J,3K
42	314-0076	6		1C 74LS157	2A,2D,2E,2J,2K,2L
43	314-0078	2		1C 74LS02	3W,4D
44	314-0087	1		1C 74LS139	5M
45	314-0093	1		1C 74LS374	4B
46	314-0094	1		1C 74LS259	5N
47	314-0095	1		1C 8224	1C
48	314-0096	1		1C 74LS92	3L
49	314-0097	2		1C 74LS161	3S,3T
50	314-0098	2		1C 74LS194	2B,2C
51	314-0099	1		1C 74LS245	3E
52	314-0100	2		1C 74LS273	2R,2S
53	314-0101	2		1C 74LS283	3P,3R
54	314-0102	6		1C 74LS367	2N,2P,3C,3D,5D,5F
55	314-0103	2		1C 74LS368	5B,5C
56	315-0014	1		1C 8080	1F
57	315-0018	2		1C 2111	1V,1W
58	315-0019	1		1D 2708	3A
59	315-0045	1		1C CD4066	6N
60	315-0046	2		1C 2114 / 2114L RAM	3F,3H
61	470-0102	18		RES 1K OHM 1/4W 5%	R2-4,6-8,27-29,35,53,65
62	470-0103	2		RES 10K OHM 1/4W 5%	R24, R55
63	470-0104	1		RES 100K OHM 1/4W 5%	R49
64	470-0223	11		RES 22K OHM 1/4W 5%	R1, R9-R16, R30 R50

**Grenthin Industries, Inc.**  
San Diego, California 92123

**PARTS LIST**

**TITLE**  
ASSY VIDEO LOGIC  
G. B

825-0001  
DWG NO

SH 2  
OF 9  
REV A

ITEM NO	PART NO	QTY PER ASSY				DESCRIPTION	REF DES
1	150-0001	3				CAP E 22 $\mu$ F 35V	C20, C28, C35
2	150-0004	9				CAP E 10 $\mu$ F 10V	C19, C27, C31, C36, C39,
							C45, C47, C49, C59
3	150-0005	1				CAP E 4700 $\mu$ F 16V	C85
4	150-0008	1				CAP E 2200 $\mu$ F 16V	C63
5	150-0012	2				CAP E 47 $\mu$ F 10V	C62, C67
6	150-0017	2				CAP E 35 $\mu$ F 25V	C1, C11
7	150-0031	1				CAP E 470 $\mu$ F 16V	C80
8	150-0032	1				CAP E 220 $\mu$ F 10V	C52
9	150-0033	1				CAP E 1000 $\mu$ F 25V	C64
10	151-0002	1				CAP CER 100 $\mu$ F 50V	C94
11	151-0008	1				CAP CER .001 $\mu$ F 50V	C84
12	151-0011	13				CAP CER .01 $\mu$ F 50V	C222-26, 29, 42, 55, 56, 81, 82, 88
13	151-0012	2				CAP CER .1 $\mu$ F 50V	C60, C61
14	151-0013	1				CAP CER 10 $\mu$ F 50V	C18
15	151-0017	43				CAP CER .1 $\mu$ F 12V	C3-C9, C10, C12-C16, C21, C30,
							C32-C34, C37, C38, C40,
							C41, C43, C44, C46, C48,
							C50, C51, C53, C54, C66,
							C72, C73, C76-C79, C86,
							C87, C89, C91-C93
16	153-0001	1				CAP TANT 10 $\mu$ F 10V	C17
17	153-0002	3				CAP TANT 1 $\mu$ F 25V	C33, C57, C65
18	153-0003	1				CAP TANT 2.2 $\mu$ F 25V	C58



REVISIONS				
ZONE	LTR	DESCRIPTION	DATE	APPROVED
A		INITIAL RELEASE	1-19-79	

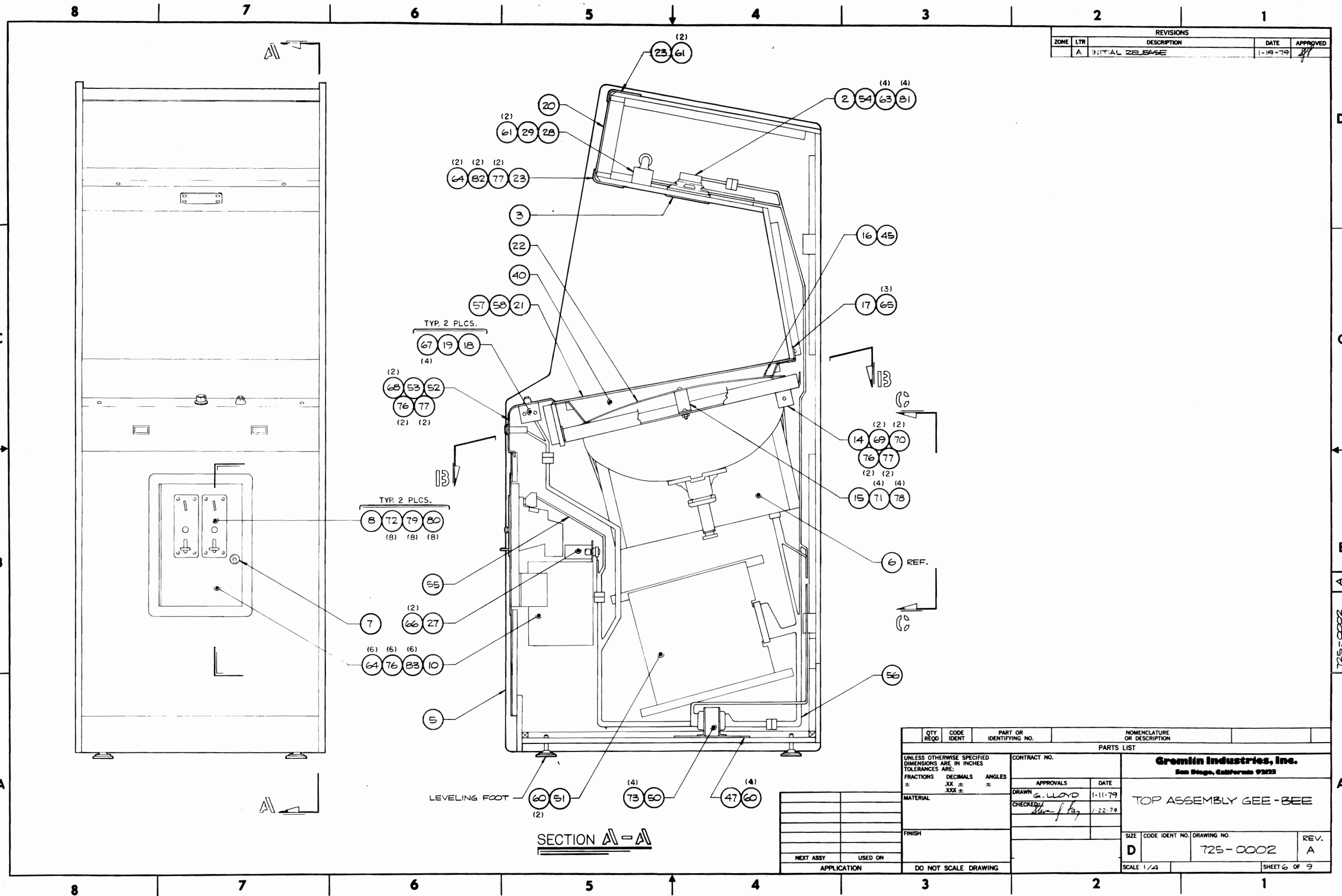

QTY REQD	CODE IDENT	PART OR IDENTIFYING NO.	NOMENCLATURE OR DESCRIPTION
PARTS LIST			
UNLESS OTHERWISE SPECIFIED DIMENSIONS ARE IN INCHES TOLERANCES ARE:		CONTRACT NO.	
FRACTIONS	DECIMALS	ANGLES	
±	.XX ±	±	
	.XXX ±		
MATERIAL		APPROVALS	DATE
FINISH		DRAWN G. LLOYD	1-11-79
NEXT ASSY		CHECKED/	1-22-79
USED ON		Gremlin Industries, Inc. San Diego, California 92123	
APPLICATION		TOP ASSEMBLY GEE-BEE	
DO NOT SCALE DRAWING		SIZE	CODE IDENT NO. DRAWING NO. REV.
		D	725-0002 A
		SCALE 1/4	SHEET 6 OF 9

725-0002

8 7 6 5 4 3 2 1

REVISIONS				
ZONE	LTR	DESCRIPTION	DATE	APPROVED
A		INITIAL RELEASE	1-19-79	<i>[Signature]</i>

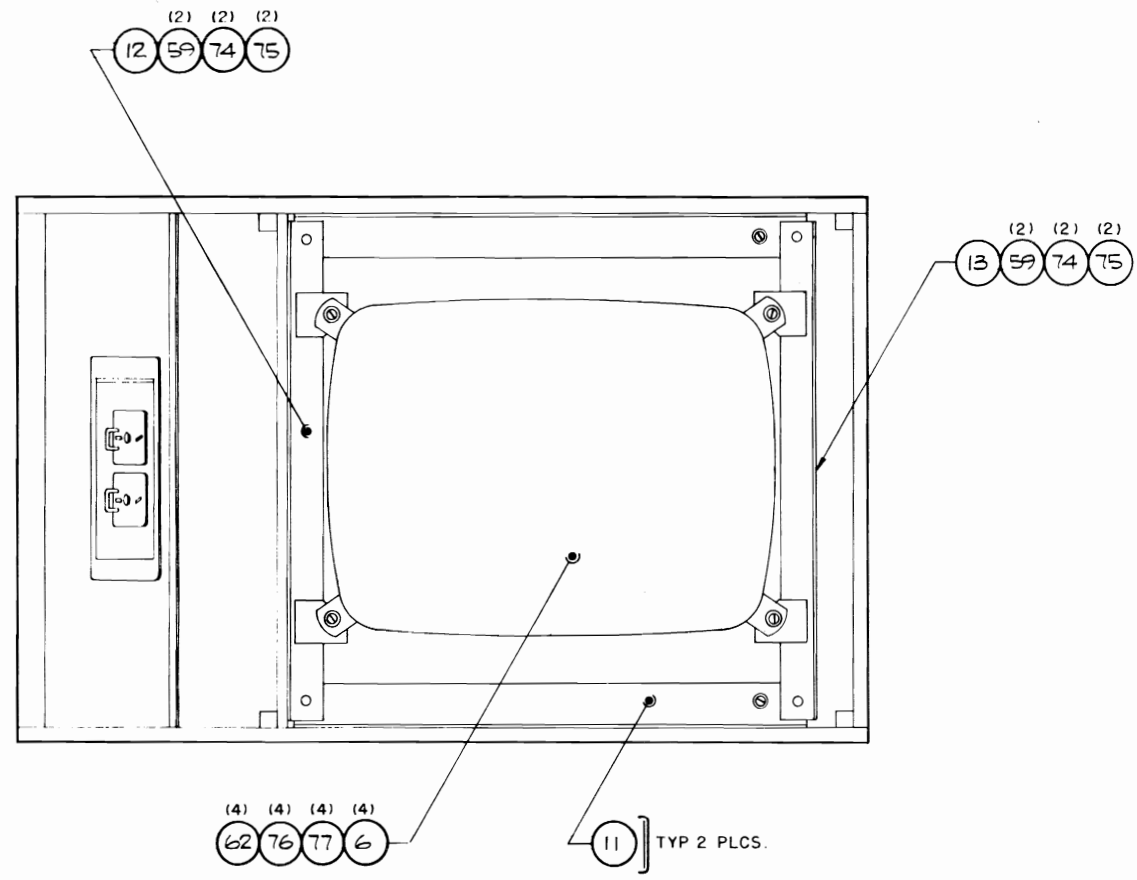

SECTION B-B

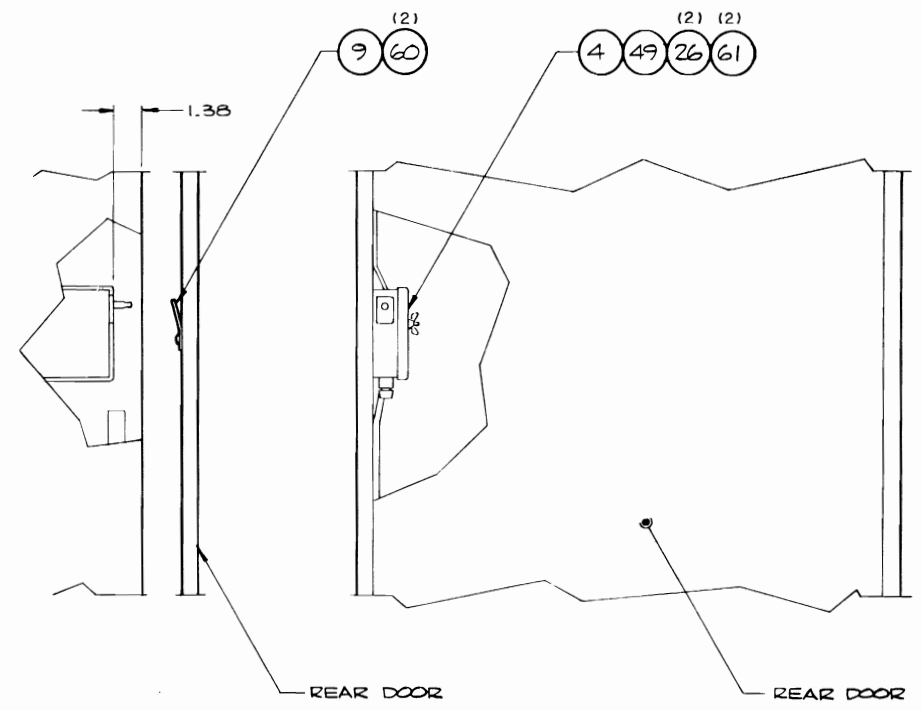

VIEW C-C

725-0002

QTY REQD	CODE IDENT	PART OR IDENTIFYING NO.	NOMENCLATURE OR DESCRIPTION
PARTS LIST			
UNLESS OTHERWISE SPECIFIED DIMENSIONS ARE IN INCHES TOLERANCES ARE:		CONTRACT NO.	
FRACTIONS	DECIMALS	ANGLES	
±	.XX ±	±	
	.XXX ±		
MATERIAL		APPROVALS	
FINISH		DATE	
NEXT ASSY		DRAWN <i>G. LLOYD</i> 1-16-79	
USED ON		CHECKED <i>[Signature]</i> 1-22-79	
APPLICATION		TOP ASSEMBLY GEE - BEE	
DO NOT SCALE DRAWING		GREMLIN INDUSTRIES, Inc. San Diego, California 92123	
		SIZE CODE IDENT NO. DRAWING NO.	
		D 725-0002	
		REV. A	
		SCALE 1/4	
		SHEET 7 OF 9	

8 7 6 5 4 3 2 1

8 7 6 5 4 3 2 1

REVISIONS				
ZONE	LTR	DESCRIPTION	DATE	APPROVED
A		INITIAL RELEASE	1-19-79	<i>[Signature]</i>

LOGIC BOARD//825-0001

MAIN HARNESS//825-0006

CRT MODULE//200-0009

HARNESS//825-0005  
COIN ACCEPTOR//220-0074

CONTROL PANEL//  
825-0002

JUNCTION BOX//807-0009

SPEAKER//130-0001

POWER SUPPLY//825-0007

CABINET WIRING DIAGRAM

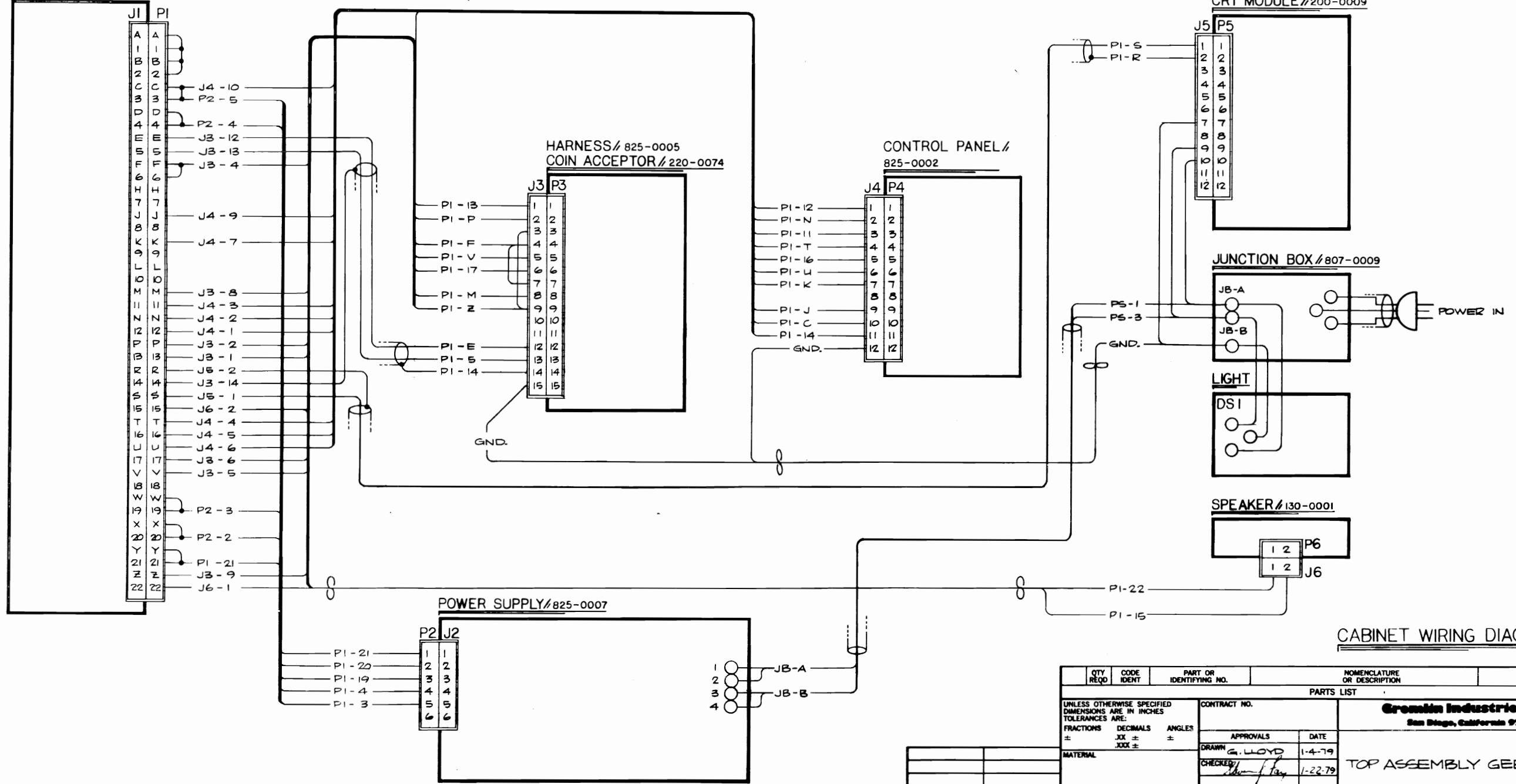

QTY REQD	CODE IDENT	PART OR IDENTIFYING NO.	NOMENCLATURE OR DESCRIPTION
PARTS LIST			
UNLESS OTHERWISE SPECIFIED DIMENSIONS ARE IN INCHES TOLERANCES ARE:		CONTRACT NO.	
FRACTIONS ±	DECIMALS ±	ANGLES ±	APPROVALS
	JXX ±	JXXX ±	DATE
MATERIAL		DRAWN G. LLOYD 1-4-79	
FINISH		CHECKED <i>[Signature]</i> 1-22-79	
NEXT ASSY USED ON		SIZE CODE IDENT NO. DRAWING NO.	
APPLICATION		D 725-0002	
DO NOT SCALE DRAWING		SCALE NONE	
		SHEET 6 OF 9	

8 7 6 5 4 3 2 1

725-0002

A

REVISIONS				
ZONE	LTR	DESCRIPTION	DATE	APPROVED
A		INITIAL RELEASE	1-19-79	<i>[Signature]</i>

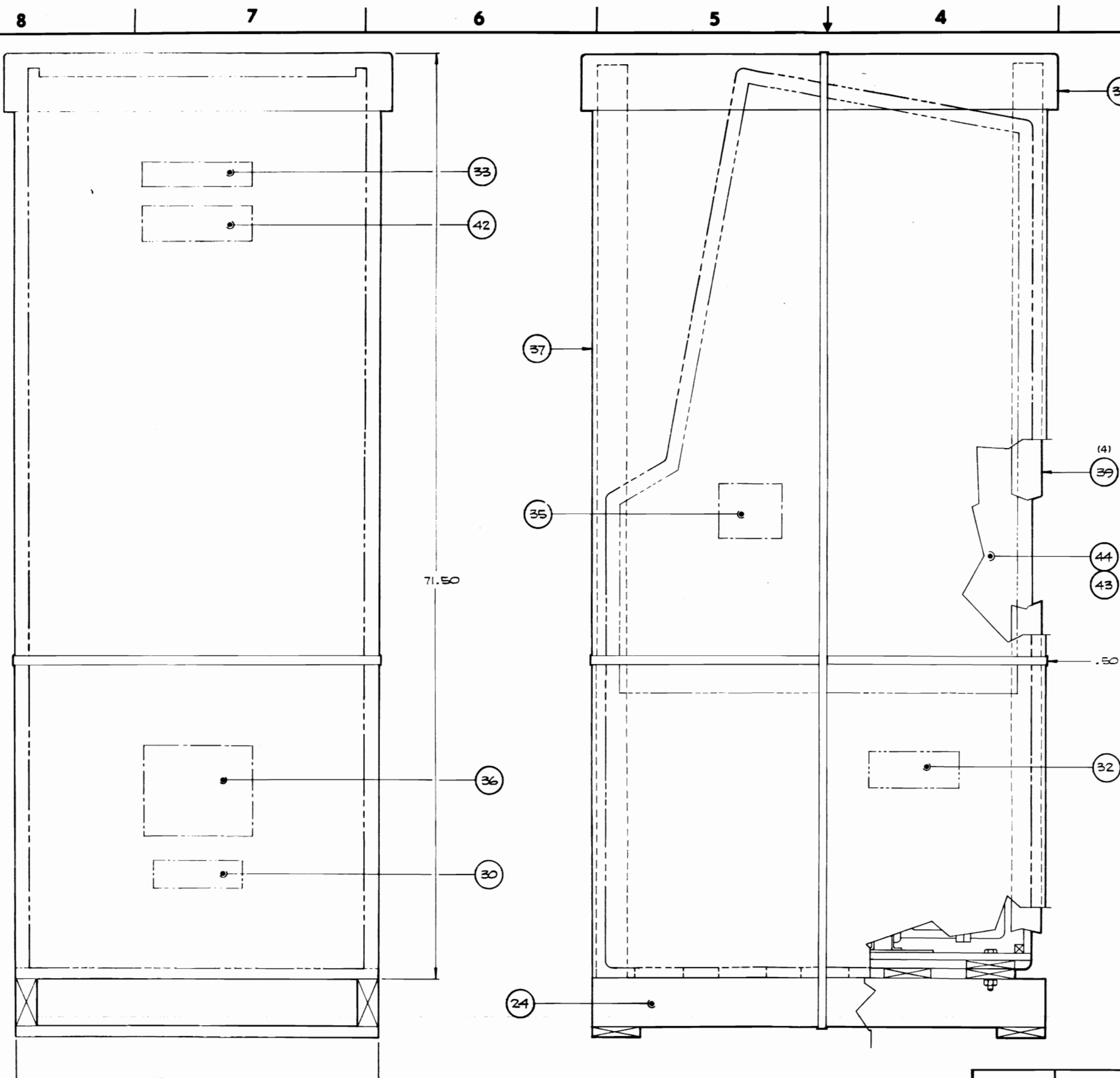

CONTAINER DETAIL

QTY REQD	CODE IDENT	PART OR IDENTIFYING NO.	NOMENCLATURE OR DESCRIPTION
PARTS LIST			
UNLESS OTHERWISE SPECIFIED DIMENSIONS ARE IN INCHES TOLERANCES ARE:		CONTRACT NO.	
FRACTIONS	DECIMALS	ANGLES	
±	.XX ±	±	
	.XXX ±		
MATERIAL		APPROVALS	DATE
FINISH		<i>G. Lloyd</i>	1-15-79
NEXT ASSY		CHECKED	<i>[Signature]</i> 1-22-79
USED ON		Grown Industries, Inc. San Diego, California 92123	
APPLICATION		TOP ASSEMBLY GEE-BEE	
DO NOT SCALE DRAWING		SIZE	CODE IDENT NO. DRAWING NO. REV.
		D	725-0002 A
		SCALE 1/4"	SHEET 9 OF 9

725-0002

REVISIONS				
ZONE	LTR	DESCRIPTION	DATE	APPROVED
A		RELEASED	WLB 1-10-79	[Signature]

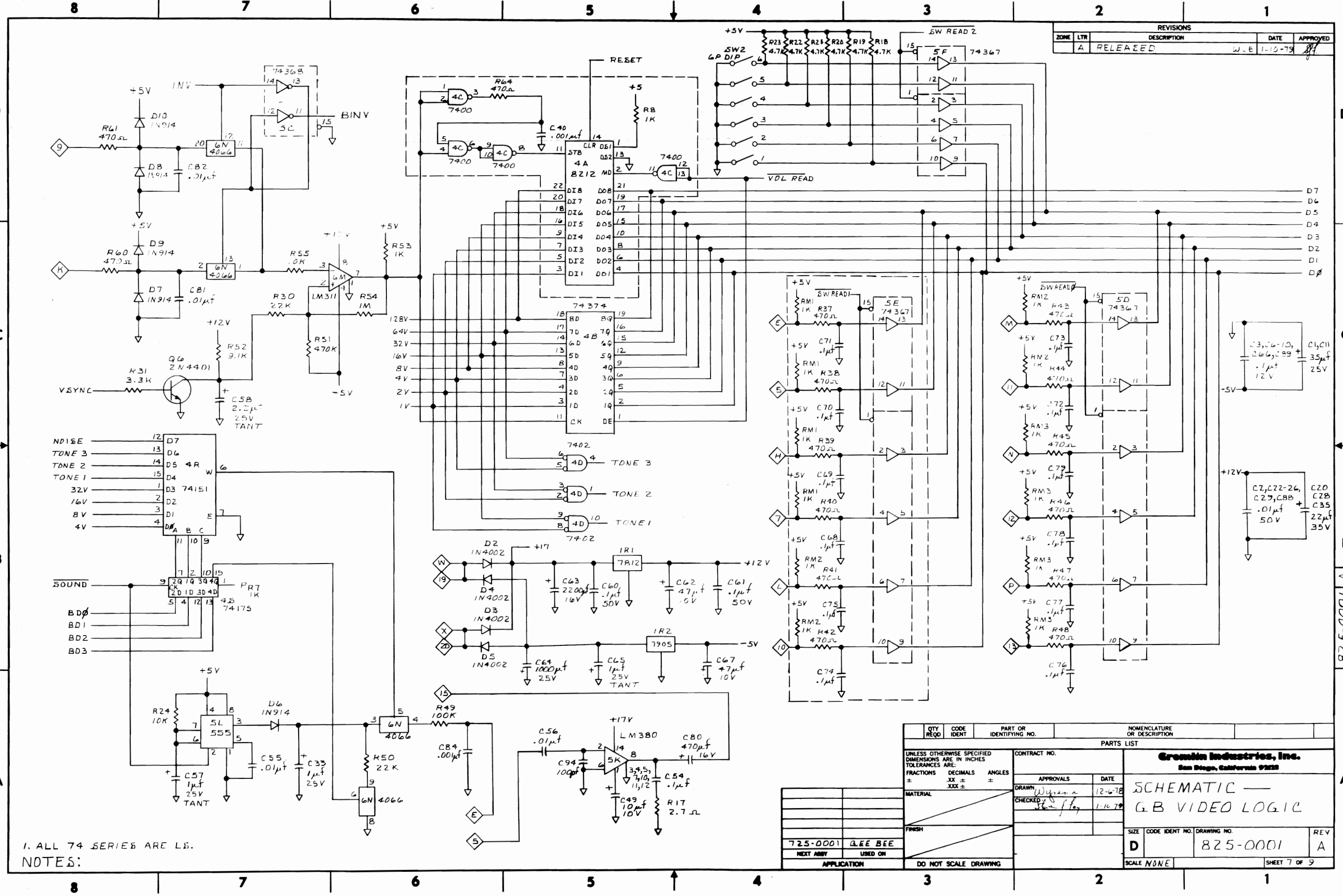

1. ALL 74 SERIES ARE LS.  
NOTES:

QTY REQD	CODE IDENT	PART OR IDENTIFYING NO.	NOMENCLATURE OR DESCRIPTION
PARTS LIST			
UNLESS OTHERWISE SPECIFIED DIMENSIONS ARE IN INCHES TOLERANCES ARE: FRACTIONS DECIMALS ANGLES ± .010 ± .005 ± .005 ±			
MATERIAL		CONTRACT NO.	
FINISH		APPROVALS DATE	
725-0001 GLEEE BEE		DRAWN W. J. [Signature] 12-6-78	
NEXT ASSY USED ON		CHECKED J. [Signature] 1-10-79	
APPLICATION		DO NOT SCALE DRAWING	
SIZE CODE IDENT NO. DRAWING NO.		REV	
D 825-0001		A	
SCALE NONE		SHEET 7 OF 9	

825-0001 A

REVISIONS				
ZONE	LTR	DESCRIPTION	DATE	APPROVED
A	RELEASED		WJB 1-10-79	

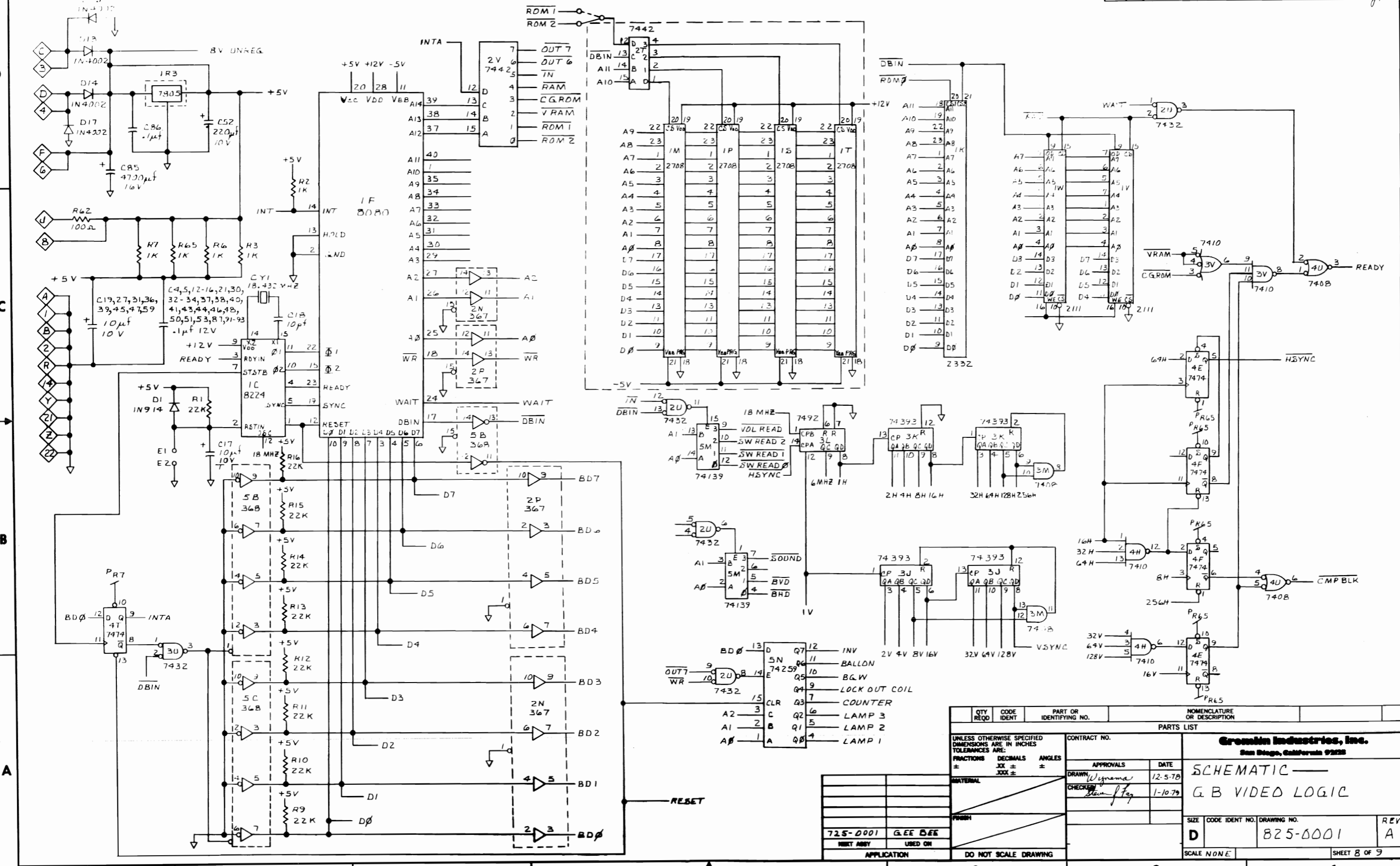

- Q7 12 INV
- Q6 11 BALLON
- Q5 10 BGW
- Q4 9 LOCK OUT COIL
- Q3 7 COUNTER
- Q2 6 LAMP 3
- Q1 5 LAMP 2
- Q0 4 LAMP 1

QTY	CODE	PART OR IDENTIFYING NO.	NOMENCLATURE OR DESCRIPTION
PARTS LIST			
UNLESS OTHERWISE SPECIFIED DIMENSIONS ARE IN INCHES TOLERANCES ARE:			CONTRACT NO.
FRACTIONS	DECIMALS	ANGLES	
±	±	±	APPROVALS
MATERIAL			DATE
FINISH			CHECKER
APPLICATION			SCALE NONE
DO NOT SCALE DRAWING			SHEET 8 OF 9

**Crown Industries, Inc.**  
San Diego, California 92128

**SCHMATIC**

**GB VIDEO LOGIC**

SIZE D CODE IDENT NO. DRAWING NO. 825-0001 REV A

825-0001 A

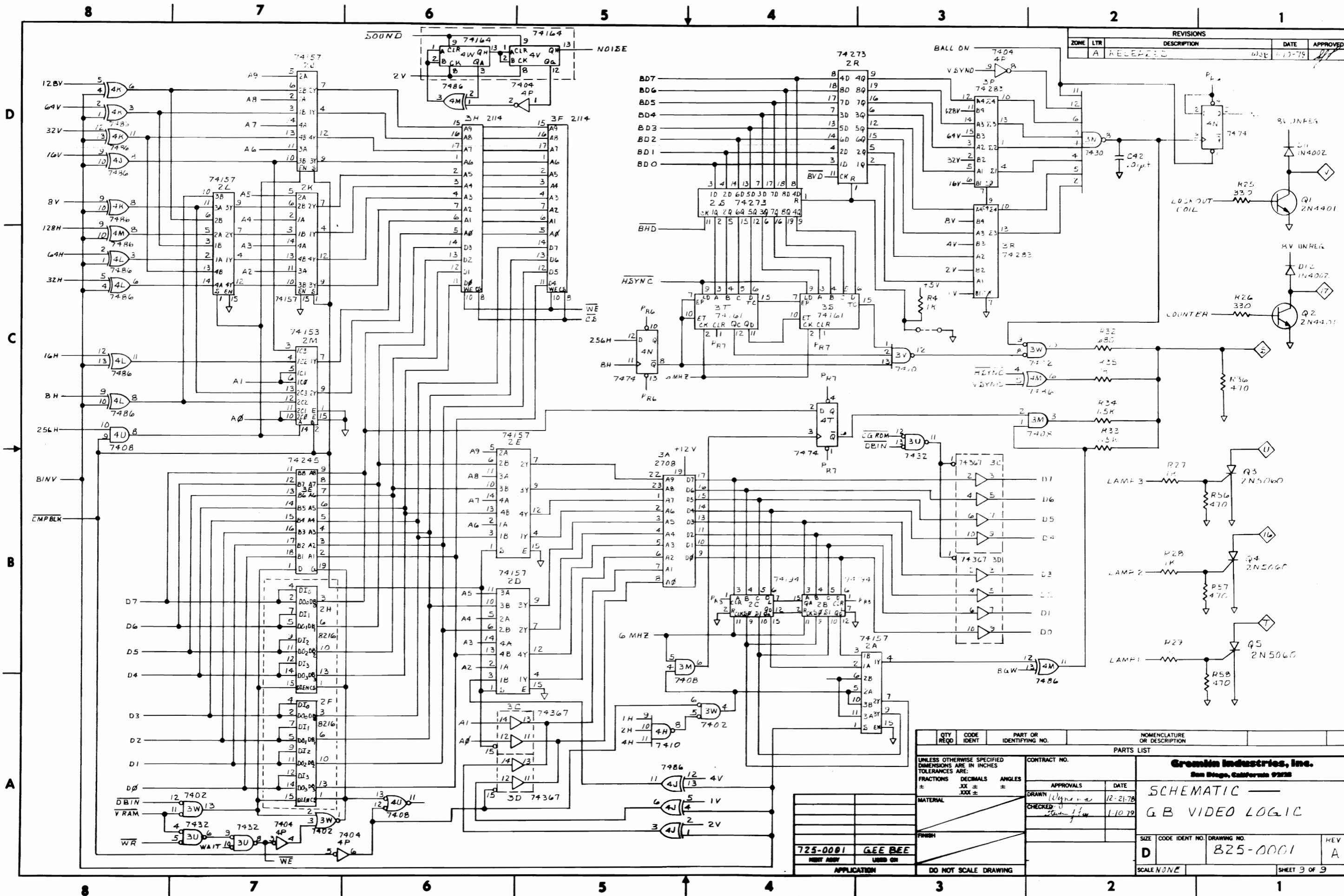

REVISIONS				
ZONE	LTR	DESCRIPTION	DATE	APPROVED
A	RELEASED		11-17-78	

QTY REQD	CODE IDENT	PART OR IDENTIFYING NO.	NOMENCLATURE OR DESCRIPTION
PARTS LIST			
UNLESS OTHERWISE SPECIFIED DIMENSIONS ARE IN INCHES TOLERANCES ARE:			
FRACTIONS	DECIMALS	ANGLES	
±	±	±	
MATERIAL			
FINISH			
APPLICATION			
DO NOT SCALE DRAWING			

CONTRACT NO.		Gretlin Industries, Inc. San Diego, California 92128	
APPROVALS	DATE	SCHEMATIC	
Wynne	12-21-78	GB VIDEO LOGIC	
CHECKED	DATE	SIZE	CODE IDENT NO.
Stewart	1-10-79	D	825-0001
		DRAWING NO.	REV
		825-0001	A
		SCALE	SHEET 9 OF 9
		NONE	

825-0001 A

REVISIONS				
ZONE	LTR	DESCRIPTION	DATE	APPROVED
A		RELEASED	1-22-79	WJB

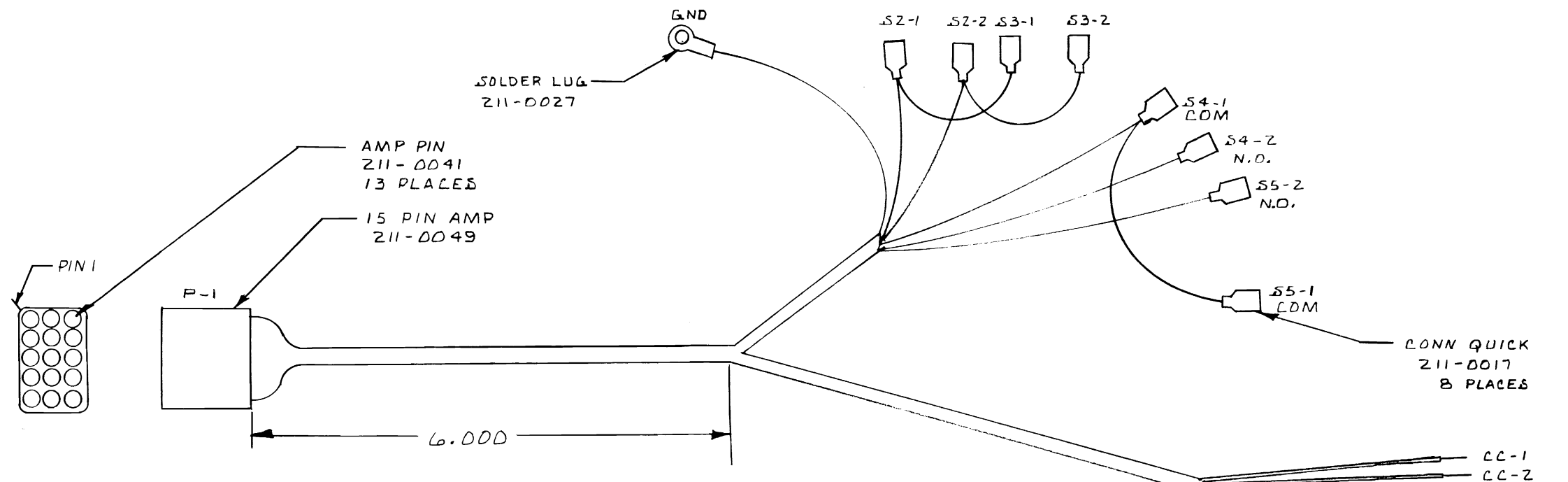

PI-15	GND	22	GRN	19
PI-14	RI-1	SHLD CABLE	SHIELD	25
PI-13	RI-2	SHLD CABLE	WHT	25
PI-12	RI-3	SHLD CABLE	BLK	25
PI-11	BLANK	---	---	---
PI-10	BLANK	---	---	---
PI-9	S1-2	22	WHT/GRN	25
PI-8	S1-1	22	GRY	25
PI-7	CC-2	22	RED	25
PI-6	CC-1	22	WHT/BRN	25
S2-2	S3-2	22	BLU	6
PI-5	S2-2	22	BLU	20
S2-1	S3-1	22	RED	6
PI-4	S2-1	22	RED	20
S4-1	S5-1	22	WHT/GRN	6
PI-3	S4-1	22	WHT/GRN	23
PI-2	S5-2	22	BRN	26
PI-1	S4-2	22	WHT	23
FROM	TO	AWG	COLOR	INCH

2. CABLE TIES 280-0005 APPROX. 6" APART  
 1. STRIP WIRES BACK 1/4"  
 NOTES:

725-0002	
NEXT ASSY	USED ON
APPLICATION	DO NOT SCALE DRAWING

QTY REQD	CODE IDENT	PART OR IDENTIFYING NO.	NOMENCLATURE OR DESCRIPTION
PARTS LIST			
UNLESS OTHERWISE SPECIFIED DIMENSIONS ARE IN INCHES TOLERANCES ARE: FRACTIONS DECIMALS ANGLES ± .XX ± ±		CONTRACT NO.	<b>Gremlin Industries, Inc.</b> San Diego, California 92123
MATERIAL		APPROVALS DATE DRAWN <i>Wynema</i> 1-19-79 CHECKED <i>Steve Fay</i> 1-22-79	
FINISH		ASSEMBLY— HARN COIN MECH	
NEXT ASSY		SIZE	CODE IDENT NO. DRAWING NO. REV
APPLICATION		C	825-0005 A
		SCALE NONE	SHEET 1 OF 1

825-0005 A



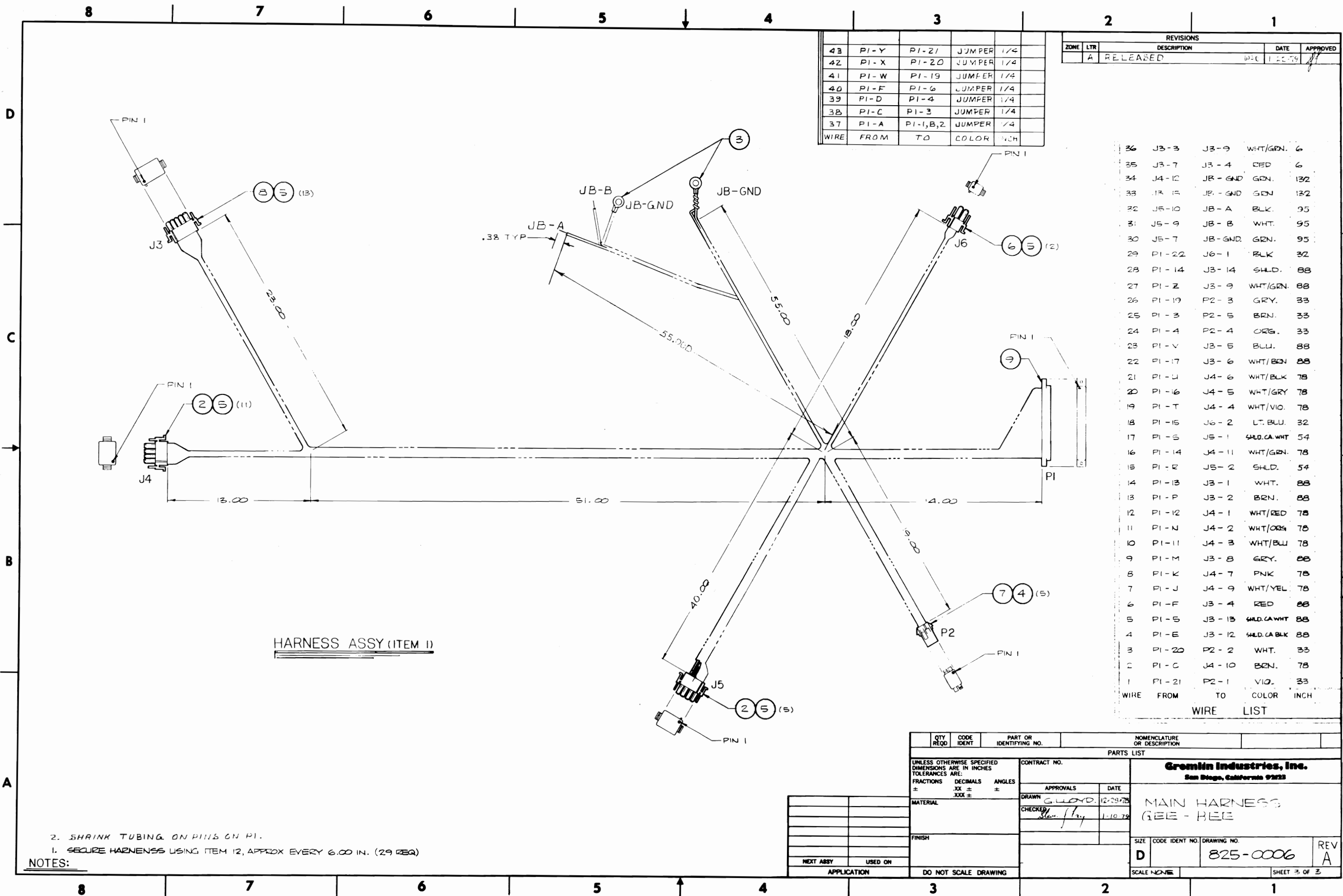

HARNESS ASSY (ITEM 1)

43	PI-Y	PI-21	JUMPER	1/4
42	PI-X	PI-20	JUMPER	1/4
41	PI-W	PI-19	JUMPER	1/4
40	PI-F	PI-6	JUMPER	1/4
39	PI-D	PI-4	JUMPER	1/4
38	PI-C	PI-3	JUMPER	1/4
37	PI-A	PI-1,B,2	JUMPER	1/4
WIRE	FROM	TO	COLOR	INCH

REVISIONS				
ZONE	LTR	DESCRIPTION	DATE	APPROVED
	A	RELEASED	DEC 1 22 79	

WIRE	FROM	TO	COLOR	INCH
36	J3-3	J3-9	WHT/GRN.	6
35	J3-7	J3-4	RED	6
34	J4-12	JB-GND	GRN.	132
33	J3-15	JB-GND	GRN.	132
32	J5-10	JB-A	BLK.	95
31	J5-9	JB-B	WHT.	95
30	J5-7	JB-GND	GRN.	95
29	PI-22	J6-1	BLK	32
28	PI-14	J3-14	SHLD.	88
27	PI-2	J3-9	WHT/GRN.	88
26	PI-19	P2-3	GRY.	33
25	PI-3	P2-5	BRN.	33
24	PI-4	P2-4	ORG.	33
23	PI-V	J3-5	BLU.	88
22	PI-17	J3-6	WHT/BRN	88
21	PI-U	J4-6	WHT/BLK	78
20	PI-16	J4-5	WHT/GRY	78
19	PI-T	J4-4	WHT/VIO.	78
18	PI-15	J6-2	LT. BLU.	32
17	PI-S	J5-1	SHLD. CA WHT	54
16	PI-14	J4-11	WHT/GRN.	78
15	PI-R	J5-2	SHLD.	54
14	PI-13	J3-1	WHT.	88
13	PI-P	J3-2	BRN.	88
12	PI-12	J4-1	WHT/RED	78
11	PI-N	J4-2	WHT/ORG	78
10	PI-11	J4-3	WHT/BLU	78
9	PI-M	J3-8	GRY.	88
8	PI-K	J4-7	PNK	78
7	PI-J	J4-9	WHT/YEL	78
6	PI-F	J3-4	RED	88
5	PI-S	J3-13	SHLD. CA WHT	88
4	PI-E	J3-12	SHLD. CA BLK	88
3	PI-20	P2-2	WHT.	33
2	PI-C	J4-10	BRN.	78
1	PI-21	P2-1	VIO.	33

NOTES:  
 2. SHRINK TUBING ON PINS ON PI.  
 1. SECURE HARNESS USING ITEM 12, APPROX EVERY 6.00 IN. (29 REQ)

QTY REQD	CODE IDENT	PART OR IDENTIFYING NO.	NOMENCLATURE OR DESCRIPTION
PARTS LIST			
UNLESS OTHERWISE SPECIFIED DIMENSIONS ARE IN INCHES TOLERANCES ARE:		CONTRACT NO.	
FRACTIONS ±	DECIMALS .XX ±	ANGLES ±	APPROVALS
			DATE
MATERIAL	FINISH	DRAWN G. LLOYD 12-29-78	
		CHECKED [Signature] 1-10-79	
NEXT ASSY	USED ON	SIZE CODE IDENT NO. DRAWING NO.	
APPLICATION	DO NOT SCALE DRAWING	D 825-0006 REV A	
		SCALE NONE SHEET 3 OF 3	

825-0006 A