

namco[®]

CYBERSLED[™]

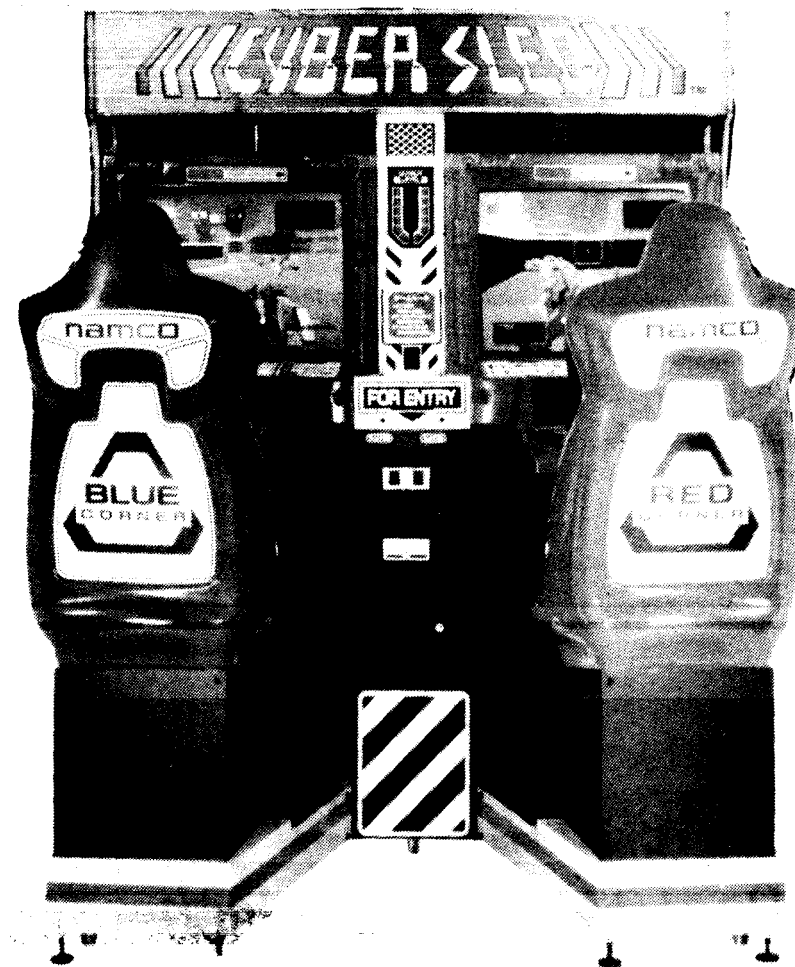

Operators Manual

© 1993 **namco** Ltd- all rights reserved

No part of this publication may be reproduced by any mechanical, photographic or electronic process, or in the form of phonographic recording, nor may it be stored in a retrieval system, transmitted or otherwise copied for public or private use, without permission from **namco** Ltd.

Published by:
BRENT LEISURE Ltd.
Namco House
Acton Park Estate
The Vale, Acton
London W3 7QE

Phone:- 0208-324-6000
Fax:- 0208-324-6000

1. SPECIFICATIONS

- 1. Power Supply: AC 220/240V
- 2. Power Consumption: 410W
- 3. Game Fee Settings One credit per one coin to nine credits per nine coins (81 ways)
- 4. Display 25" colour monitor x 2
- 5. Dimensions

Assembled:	1530 x 1900 x 1710mm (w/h/d)
Divided:	
Main Body Assy	1440 x 1900 x 986mm (w/h/d)
Seat Assy	550 x 1420 x 1030mm (w/h/d)

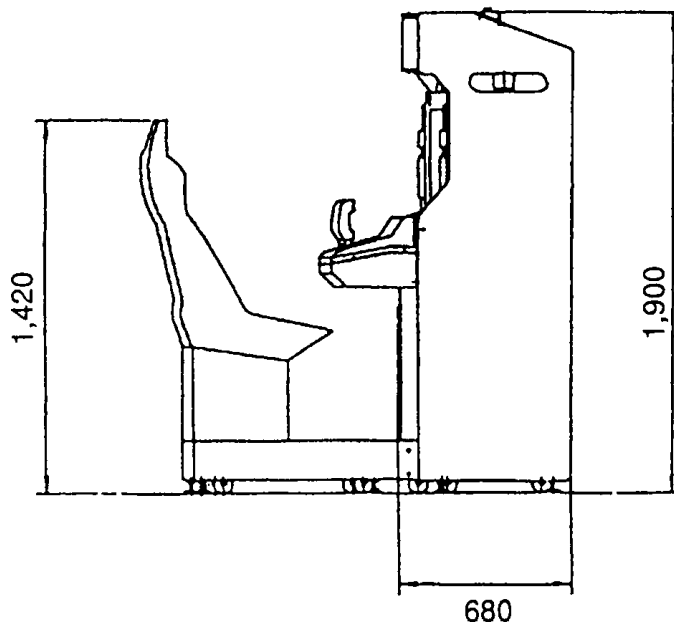
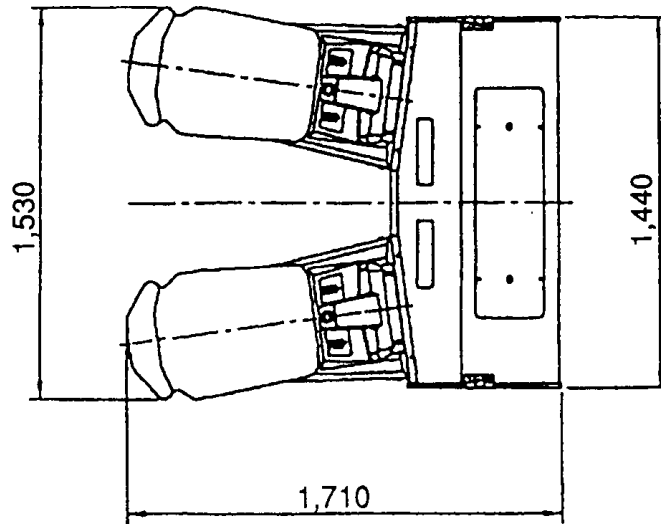

6. Weight Assembled: 270 kgs
Divided:
Main Body Assy 190kg
Seat Assy 40kg (x 2)
7. Supplied Accessories Keys (for the coin box)
Keys (for the coin door and the rear cover B)
Operation Manual

***Note: Specifications are subject to change without prior notice.
Modification and/or alternation of the Cybersled game
not supplied by NAMCO may void the warranty.***

2. Precautions - Be sure to read this section

2-1 Installation

This product is designed for indoor use only. Do not install it in the following areas:

1. Outdoors.
2. In areas directly exposed to sunlight, high humidity or dust, high heat, or extreme cold.
3. In locations near fire equipment or emergency exits or any other places where it would be an obstacle in case of emergency.
4. An unstable surface or floor subject to vibration.

2-2 Operation

1. This product operates with a power source of 220 to 240VAC. The input terminal of the transformer should be adjusted to the power source voltage to be used.
2. The machine must be earthed with a securely connected earthed plug.
3. A monitor contains areas of high voltage. Be careful during checking or adjusting the monitor.
4. When unplugging the game from an electrical outlet, always grasp the plug, not the cord.
5. Be sure to turn off the power before replacing any part or connecting/disconnecting the connectors.
6. Return the Printed Circuit Board (PCB) to your distributor for any repairs. Do not attempt to make any measurements with a multi-meter. This PCB contains sensitive chips which could be damaged even by the internal voltage of a multi-meter.
7. Adjustment is required whenever the game PCB, ROM, Lever Assy or Control Pots are changed. See "5-5 Adjustments After Replacing Parts (Initializing the Product)" on page 14 to adjust the product.

2-3 Transportation

1. Do not subject the machine to physical shock during transit or installation.
2. Be sure to set the level adjusters to their uppermost position during transit.
3. Be sure to divide this product into two parts: the main body assy and the seat assy before moving it. Keep the removed bolts screwed to the nuts of the main body assy to avoid losing them.

3. Components

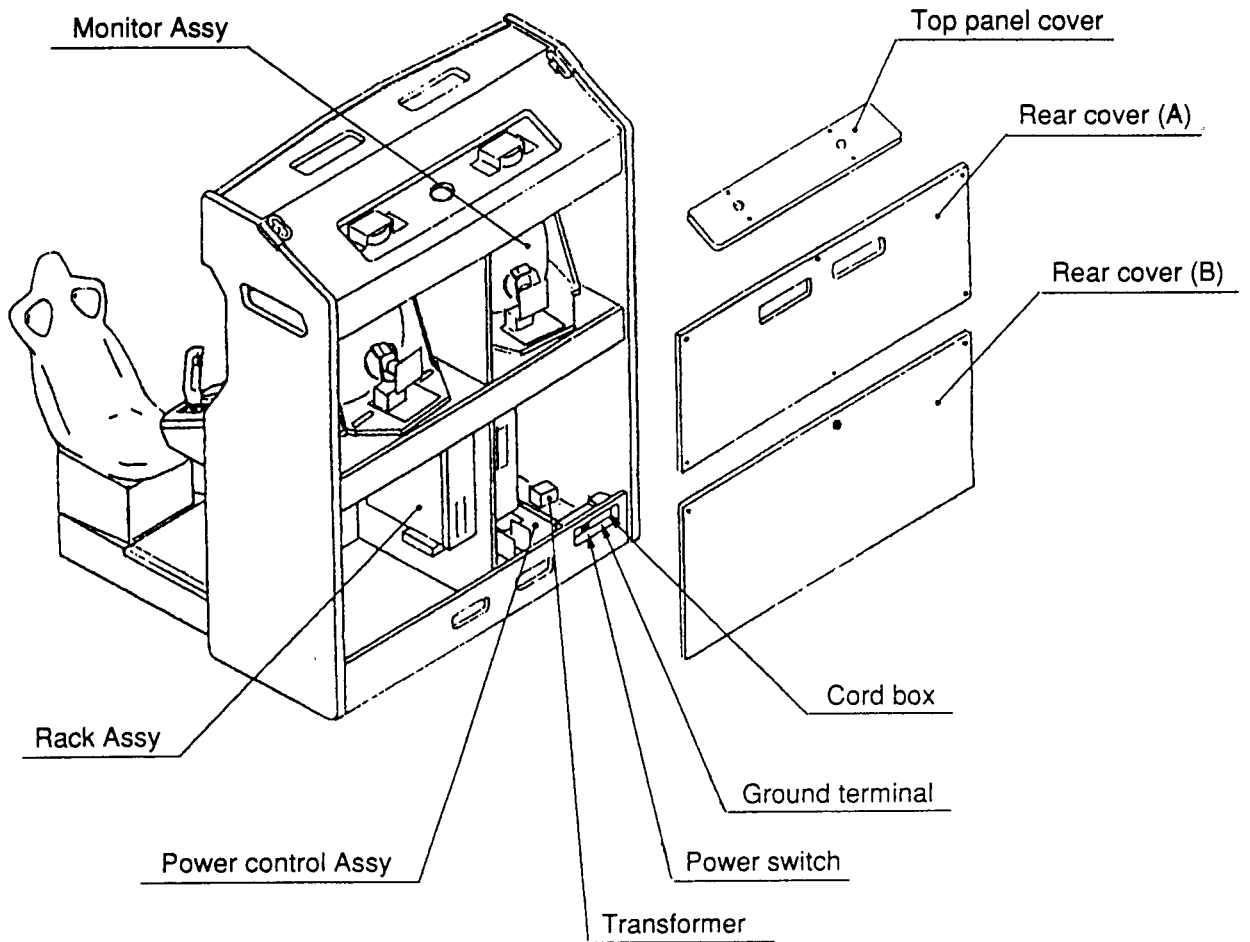
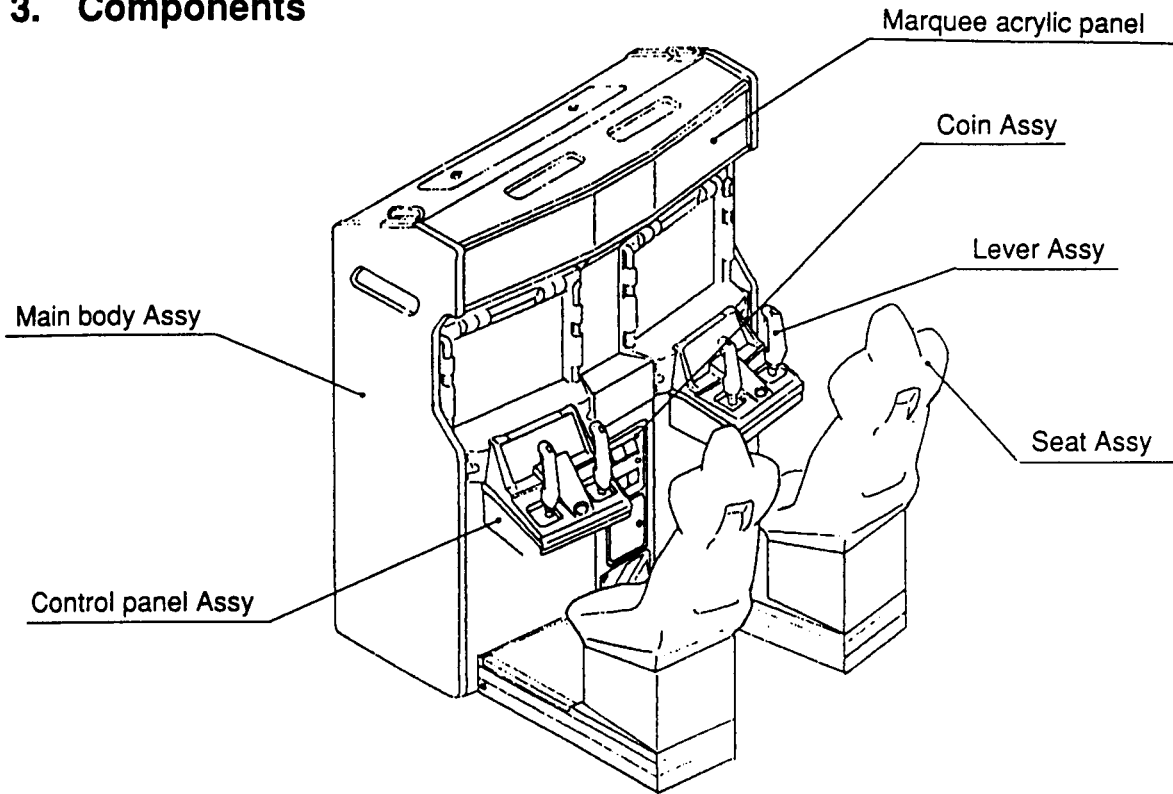

4. Installation

4-1 Connecting the Main Body Assy and the Seat Assy

1. Connect the red seat assy to the right side of the main body assy, then the blue seat assy to the left side when viewing the monitor screens.
2. Remove the tape fixing the connector (for the speaker) located at the bottom

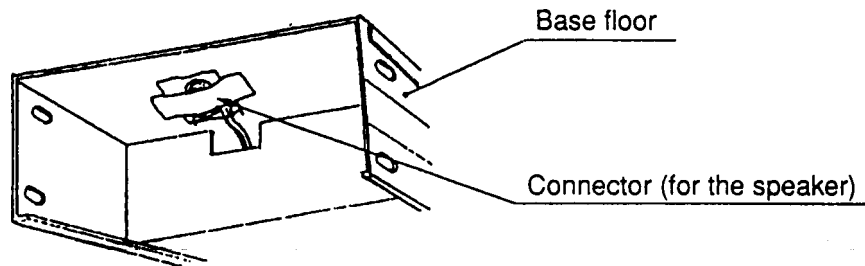

- of the base floor of each seat assy.
3. Insert each seat assy into the base floor connector of the main body assy halfway, then connect the connectors for the speaker.
4. Insert each seat assy into the main body all the way, then fix them with four flange sockets (M8 x 20).

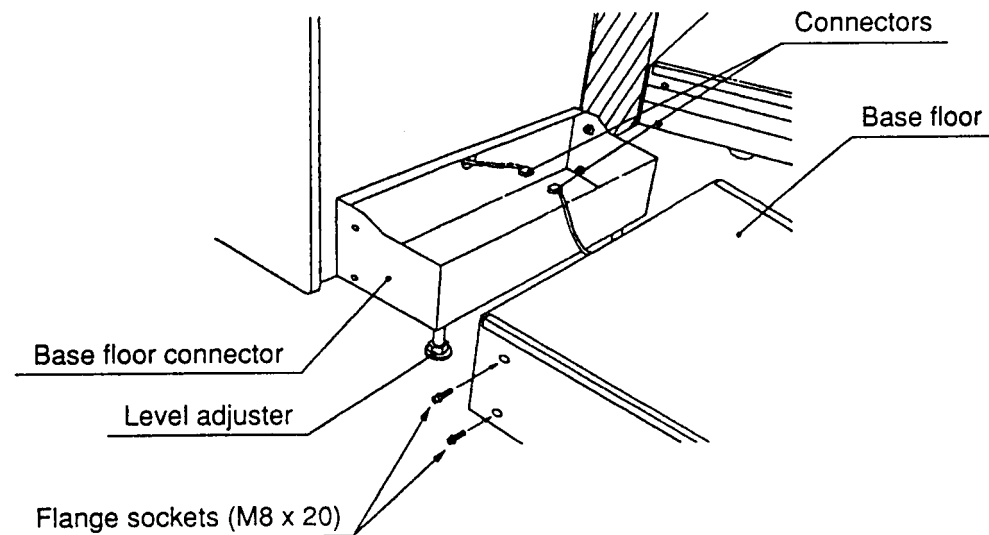

4-2 Adjusting the Level Adjusters

1. When the gasme is in its final position adjust the level adjusters of the main body assy and the seat assys (eight for the main body assy, four for the seat assy) so that the castors are lifted from the floor surface by about 5mm.

5. Adjustments

5-1 Turning the Power on

Turn the power on after installation is completed.

The power switch is located next to the mains inlet socket on the rear of the main body.

5-2 Switches for Adjustments

Open the coin door to find the switches for adjustments.

1. **Service switch.**

When this switch is pressed, a credit is established without operating the coin counter.

2. **Test switch.**

Turn this switch to ON to enter Test mode.

Changing the game pricing and various tests are performed in Test mode. (see ["5-4 test mode" on page 10](#)).

3. **Sound volume** (for control panel).

Use this volume to control the sound of the speaker located to the control panel.

4. **Sound volume** (for the seat).

Use this volume to control the sound of the speaker located on the seat assy.

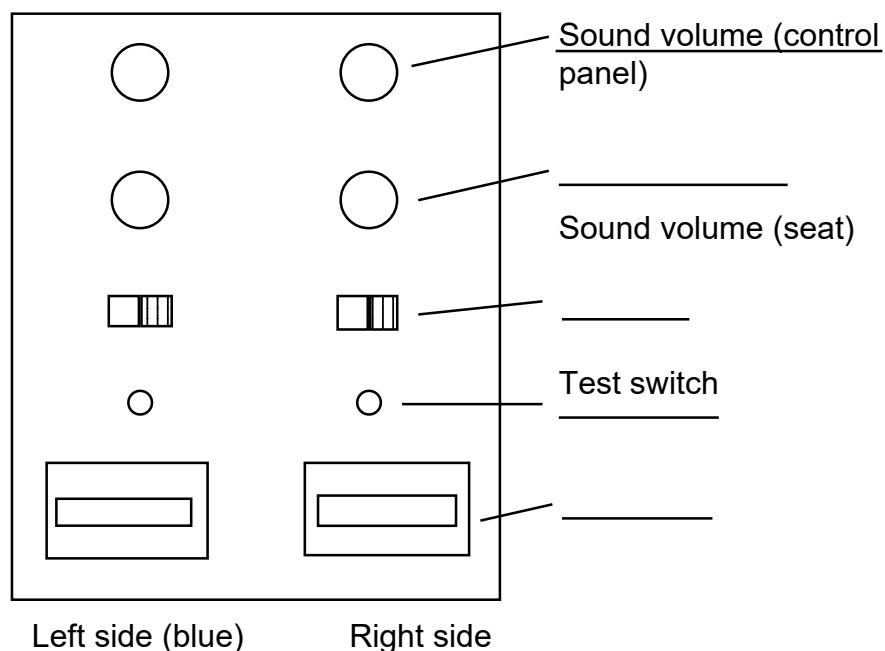

5-3 Self-Test

The self-test is performed automatically at power-on.
If no errors occur, the monitor displays the Game Screen.
If you cannot clear an error indication, or if an error indication appears every time you turn the power on, contact your distributor.

5-4 Test Mode (Changing the Game Pricing etc)

Open the coin door, set the test switch to On, then the "Menu Screen" appears on the monitor display. Select the item to be tested by shifting the joystick back or forth. The colour of the item you have selected changes.

Press the trigger to enter the item selected.

When the test finishes, turn the test switch OFF to return to the Game Screen.

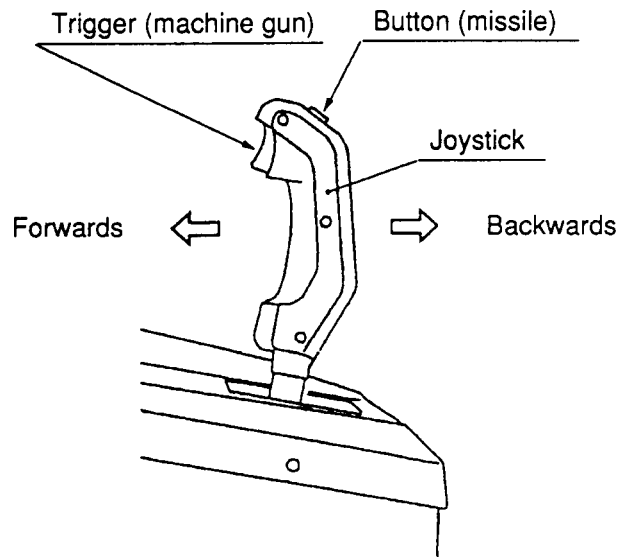

The **test switch** should always be **OFF** during **normal game** mode.

SWITCH TEST	(1)	For testing each switch
SOUND TEST	(2)	For testing various sounds
COIN OPTIONS	(3)	For changing game pricing etc. (see 5-4-1)
GAME OPTIONS	(4)	For setting the game options (see 5-4-2)
A. D. S.	(5)	For displaying the game data collected
COLOUR TEST	(6)	For adjusting the colour of the monitor display
CONVERGENCE TEST	(7)	For various monitor adjustments
LIGHT TEST	(8)	for testing the "View Point Change" button lamp
JOYSTICK ADJUST	(9)	For making minor adjustments of the joystick (see 5-5-2)

5-4-1 Changing the Game Pricing (Game Option Screen)

Select 3 "COIN OPTIONS", to change the game pricing.

You can change the setting of the item in red.

Shift the joystick back or forth to select an item.

Press the trigger or button of the joystick to change the setting.

To return to the Menu Screen, select "EXIT" or press the service switch.

COIN OPTIONS			
COIN 1 MECH	1 COUNT 1 COIN	_____	(a)
COIN 2 MECH	1 COUNT 1 COIN	_____	(b)
GAME COST	1 COIN 1 CREDIT	_____	(c)
BONUS COIN	NONE	_____	(d)
FREE PLAY	NO	_____	(e)
WIN BONUS	NO	_____	(f)
ATTRACT SOUND	YES	_____	(g)
EXIT			

Coin Option Screen

***Note: The price of play is adjusted on the credit board and coin options should be set as follows**

Table 1 Coin Option Settings

ITEM	DESCRIPTION		SET TO
(a) Coin 1 mechanism	Number of pulses on coin 1 meter per coin --- settable 1 - 9		1
(b) Coin 2 mechanism	Number of pulses on coin 2 meter per coin --- settable 1 - 9		1
(c) Game price	Number of coins necessary for credit --- settable 1 - 9		1
(d) Bonus coin	Count as extra coins when the specified number of coins have been inserted. settable 0 - 9		NONE
(e) Free play	Yes No		NO
(f) Bonus for the winner	Yes No	YES: The winner of a two player game can continue to play a single player game. During the single player game, another player can buy-in.	NO
(g) Attract sound	Yes No		YES

5-4-2 Setting the Game Options (Game Options Screen)

Select 4 "GAME OPTIONS" to display the Game Options Screen.

You can change the settings of the item in red.

Shift the joystick back or forth to select an item.

Press the trigger or button of the joystick to change the setting.

To return to the Menu Screen, select "EXIT" or press the service switch.

GAME OPTIONS					
TIME	1T	C	120	_____	(1)
TIME	1C	C	60	+22 _____	(2)
TIME	2B	C	120	_____	(3)
TIME	21A	C	70	_____	(4)
1 PLAYER LEVEL		C		_____	(5)
2 PLAYER LEVEL		C		_____	(6)
WAIT TIME		C	20	_____	(7)
WIN B TIME		C	15	_____	(8)
POSITION		1	LEFT	_____	(9)
EXIT					
LINK		OK		_____	(10)

Game Options Screen

Table 2 Game Option Settings

ITEM	DESCRIPTION
(1) Time of 1 player training	A (longest) to E (shortest) (Factory setting: C)
(2) Time of 1 player vs. computer	A (longest) to E (shortest) (Factory setting: C)
(3) Time of 2 player Beginner's	A (longest) to E (shortest) (Factory setting: C)
(4) Time of 2 player Intermediate/Advanced	A (longest) to E (shortest) (Factory setting: C)
(5) One-player game difficulties	A (easiest) to E (most difficult) (Factory setting: C)
(6) Two-player game difficulties	This setting specifies how much the opponent is damaged. A (takes long time to defeat opponent.) to (Factory setting: C) E (takes short time to defeat opponent)
(7) Waiting time for an opponent player	A (longest) to E (shortest) (Factory setting: C)
(8) Waiting time for an opponent player at the bonus game	A (longesr) to E (shortest) (Factory setting: C)
(9) Communications number settings	1 (left seat) 2 (right seat)
(10) Communications condition	OK (Communication functions OK.) ERROR (Communication error)

* You cannot select this item.

5-4-3 Switch Test

Select 1 "SWITCH TEST" to display the Switch Test Screen.

SWITCH TEST			
DIP	SW	12345678	_____ (a) Option switch (CPU-PCB)
TEST	SW	ON	_____ (b) Test Switch
COIN 1	SW	OFF 00	_____ (c) Coin 1 mechanism
COIN 2	SW	OFF 00	_____ (d) Coin 2 mechanism
SERVICE	BUTTON		_____ (e) Service switch
MISSILE	BUTTON		_____ (f) Missile button
GUN	TRIGGER		_____ (g) Machine gun trigger
VIEWPOINT	CHANGE BUTTON		_____ (h) Viewpoint change button
LEFT	JOYSTICK	00 CENTER	_____ (i) Forward/backward pot - left joystick
		00 CENTER	_____ (j) Left/right pot - left joystick
RIGHT	JOYSTCK	00 CENTER	_____ (k) Forward/backward pot - right joystick
		00 CENTER	_____ (l) Left/right pot - right joystick

Switch Test Screen

- a. The status of the option switches on the game PCB (CPU-PCB) is indicated. A switch number displayed in red is set to ON.
- b. When these letters are turned red, the test switch works normally.
- c. The number increments by one every time you press the Coin 1 switch.
- d. Not used.
- e. These letters turn red when you press the service switch inside the coin door. Press the service switch to return to the Menu Screen.
- f. These letters turn red when you press the missile button.
- g. These letters turn red when you press the machine gun trigger.
- h. These letters turn red when you press the Viewpoint change button.
- i. "UP" or "DOWN" appears when you move the left joystick forwards or backwards, "OK" appears when you move it to the most forward/backward position, and "CENTRE" appears when the joystick is returned to the middle.
- j. "RIGHT" or "LEFT" appears when you move the left joystick right or left, "OK" appears when you move it to the most right/left position, and "CENTRE" appears when the joystick is returned to the middle.
- k. The right joystick operates normally when the same indications appear as those for the left joystick according to your operation as described in (i & j).

Adjust the lever assy if the results of the tests from (i) to (l) are different from those described above. (See 5-5-1 Adjusting the Lever Assy).

5-5 Adjustments After Replacing Parts (Initialization)

The machine must be initialized when the Game PCB, the lever Assy or the volumes are replaced.

5-5-1 Adjusting the Lever Assy (Initialization)

1. Turn the test switch ON while pressing the service switch and keeping the joystick in neutral. The "VOLUME ADJUST SCREEN" appears. The lever assy is automatically initialized at this moment.
2. Set the test switch to OFF to display the "Menu Screen" again.
3. Select 1 "SWITCH TEST" to test the joysticks.
If:-

VOLUME ADJUST			
LEFT	JOYSTICK	00	CENTE
		00	CENTE
RIGHT	JOYSTICK	00	CENTE
		00	CENTE

VolumeAdjust Screen

- "CENTRE" appears when you set the joysticks in neutral.
and
- "OK" appears when you push down the joysticks all the way.
the joystick is OK

Adjustments for the joysticks are completed if there are no problems in any direction of operations for both joysticks.

4. Make minor adjustments of the joystick by selecting "JOYSTICK ADJUST" on the Menu Screen if "OK" does not appear.

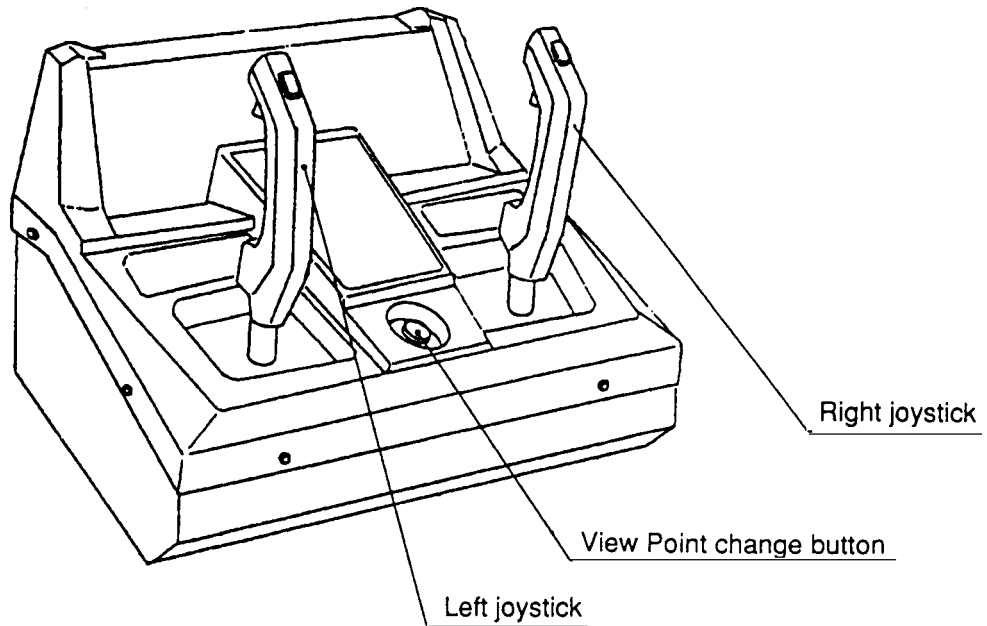

5-5-2 Minor Adjustments of the Lever Assy("JOYSTICK ADJUST")

1. Select 9 "JOYSTICK ADJUST" on the Menu Screen. The following screen

JOYSTICK ADJUST	
(LEFT)	(RIGHT)
UP	UP
DOWN	DOWN
LEFT	LEFT
RIGHT	RIGHT

Joystick Adjust Screen

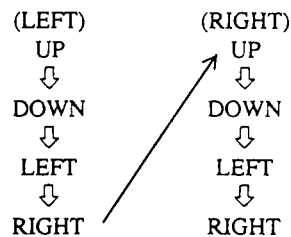

Adjustments are conducted in this order.

appears:

2. Push the left joystick forwards until it stops, then press the View Point Change button.

"OK" appears next to "UP".

Pull the left joystick backwards until it stops, then press the View Point Change button.

"OK" appears next to "DOWN".

3. In the same manner as Step (2), adjust both joysticks for all the directions.

* **Make these adjustments only after "5-5-1 Adjusting the Lever Assy (Initialization)".**

5-5-3 Initializing the Communication Number

If the communication numbers of the right and left game PCB's are not set correctly, communication will not work correctly

1. Select "POSITION" on the "GAME OPTIONS screen", then set "1" for the left side (blue seat side), then "2" for the right side (red seat side).
2. When the correct numbers are set for both the right and left sides, "OK" appears under the item "LINK".

6. How to Play

- This machine allows a player to enjoy a fighting game with another player or against the computer, driving a future tank with two joysticks and using missiles and machine gun.

[How to Control]

- Pushing both joysticks in the same direction causes the tank to move in that direction.
- Push one joystick forward and pull the other one back to turn the tank.
- Press the thumb button to launch a missile. The number of missiles to be fired is limited.
- Pull the trigger to shoot the machine guns.

Hold the trigger to keep on firing the machine gun, but not too long or the gun will overheat.

Release the trigger to let it cool down.

- There are three items: "Missile Supply", "Shield Repair" and "Special". Three effects are hidden in the "Special" item: "Jam your opponents radar", "Jam your opponents missile tracking", and "Special shield".

[Game Rules]

- Insert coins into the machine, press credit available button and wait for an opponent.
When an opponent presses credit available button within the time allowed, Two-Player mode starts. Otherwise, One-Player mode starts.
- The players can select Beginner's, Intermediate or Advanced level in the Two-Player mode.
- The Beginner's level is a training course. You can fight for unlimited rounds within the given time limit.

In the Beginner's level, the special items do not appear. (Special items do not appear in the One-Player mode either.)

- Both the Intermediate Level and the Advanced Level of the games provide full-scale of fighting stages. The players can select the battle field.

A three game match. The first player to make it through two games win.

- The advanced level of a game allows the players to select the fighting environmental factors; night or mist, by pressing the View Point change button when they select the battle field.
- In the One-Player mode, the player can select two kinds of courses: training/practice course and vs computer combat course.

The goal of each course is to clear all stages of the game within the given time limit. You can fight for unlimited rounds within the given time limit.

The training course consists of three stages, and it is provided for the beginner's to practice.

Vs computer combat course consists of six stages. Every time the player defeats the enemy, extra time is awarded.

- The waiting time for an opponent can be shortened by pressing/pulling the missile button trigger repeatedly as quickly as possible while holding the viewpoint change button.

7. Regular Maintenance

Be sure to disconnect the power before conducting any maintenance procedure.

7-1 Replacing the Fluorescent Lamps

1. Remove four torque bolts (M5 x 20) fixing the signboard metal fittings located on the upper side of the marquee acrylic panel.
2. Remove the signboard metal fittings, then the marquee acrylic panel.
3. Replace the fluorescent lamps with new ones.

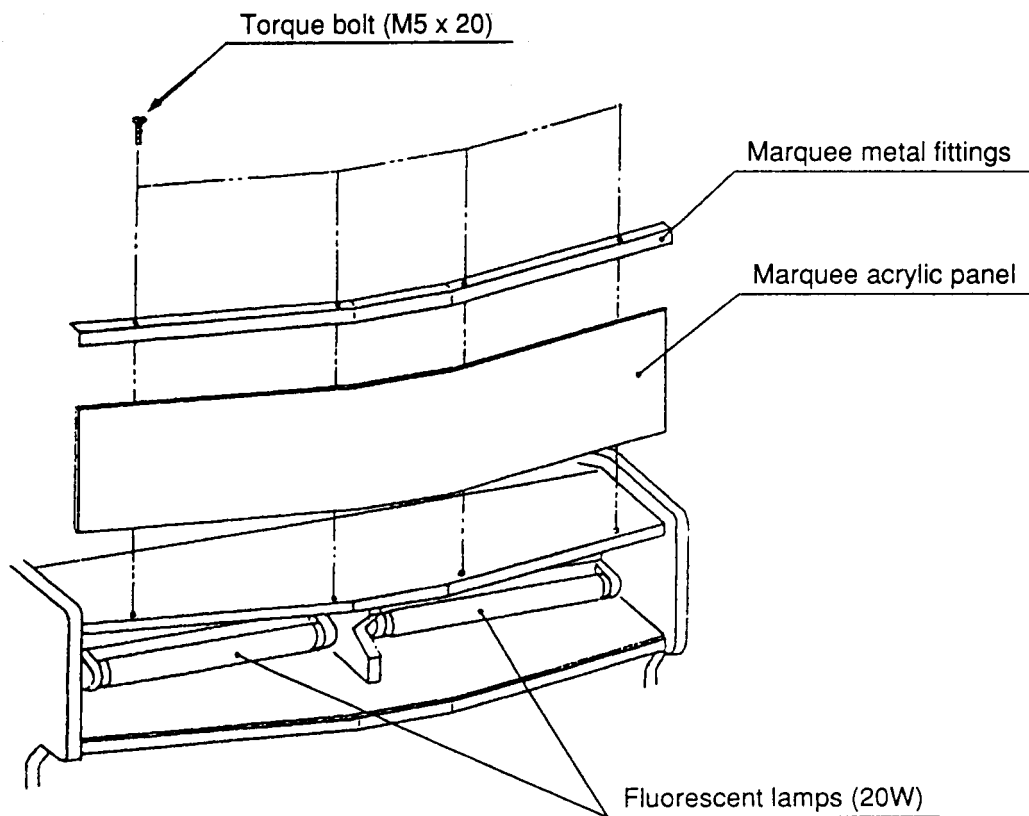

7-2 Removing the Game PC Board

This section describes removing the game PCB on the left side (blue seat).

The game PCB right side is fixed opposite, and it can be removed in the same procedure as that of the left side PCB.

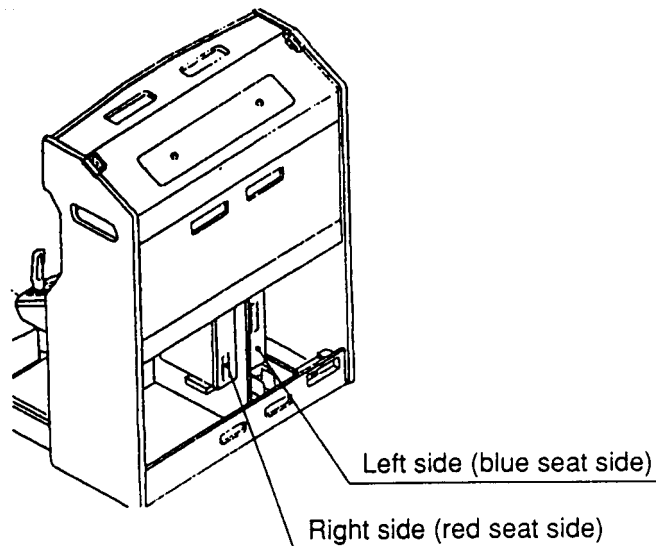

*** Power must be disconnected before removing game PCB's. ***

1. Remove the rear cover (B).
2. Remove two connectors.
3. Remove two cross-and-pan headed assembling small screws (M5 X 16), then pull out the PCB case to remove it.
4. Remove five cross-and-pan headed assembling small screws (M5 X 16), then the cover.

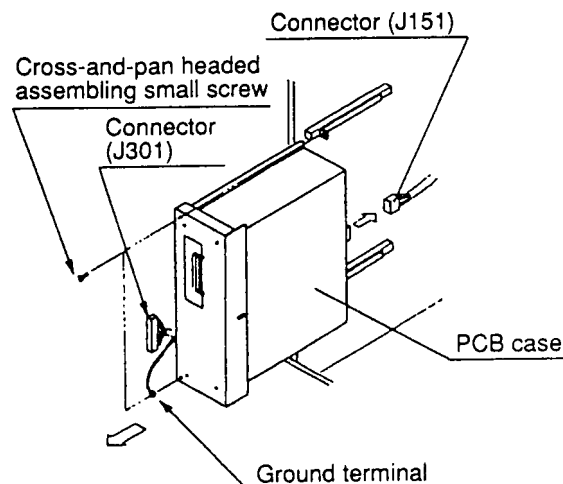

5. Remove the connectors which connect the CPU68 PCB and the OBJ (B) PCB.
6. Set the white hooks on both sides of the CPU68 PCB to the outside, then pull out and remove it.

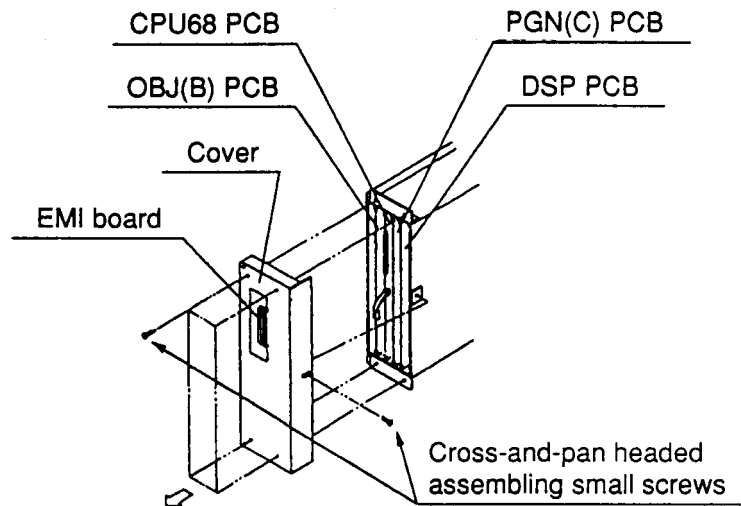

7. Remove other three PCB's in the same way.

- Notes:**
- ①. To install the PCB's, insert each one along the rails of the PCB case, then connect it to the connector. Be sure to set the white hooks to the inside.
 - ②. To fix the cover, connect the connector of the EMI board to that of the CPU68 PCB.
 - ③. To fix the PCB case, be sure to connect the ground terminal.

7-3 The Lever Assy

7-3-1 Removing the Lever Assy

1. Remove the rear cover (B) located at the back of the main body.
2. Disconnect the connector of the lever assy and that of the speaker assy.

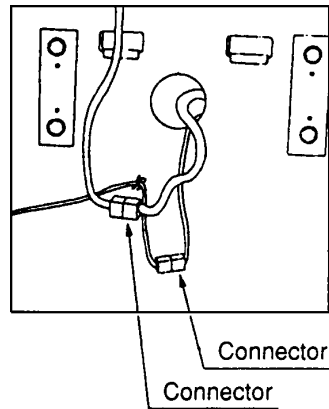

3. Remove eight torque bolts (M5 x 12), then the panel cover.
4. Remove seven cup screws (M5 x 12), then the control panel cover together with the lever assy.
5. Disconnect the connectors of the lever assy and the connector of the view point change button.
6. Remove four cup screws (M6 x 20), then remove the lever assy from the control panel cover.

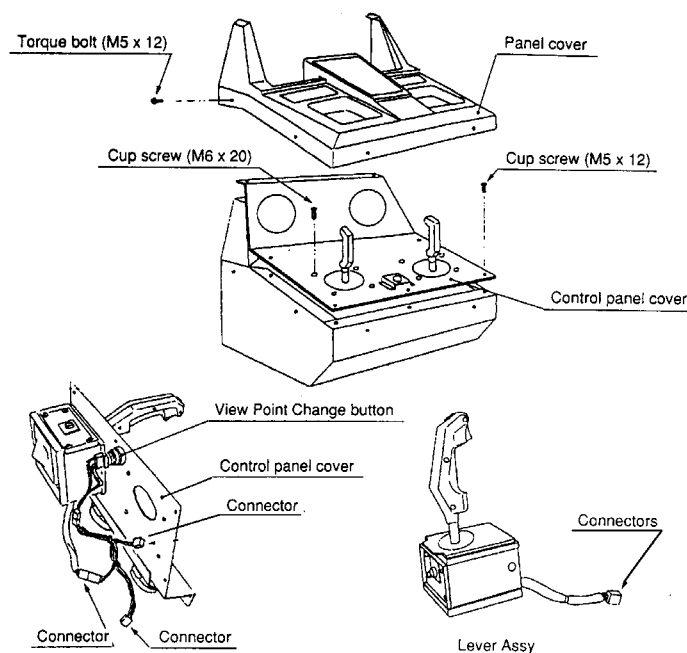

7-3-2 Replacing the Joystick Volume Pots

1. Remove the 4 x Philips hex head screws retaining the volume plate to the main assy
2. Replace the volume pot
3. Re-fit in reverse order taking care that the volume pot shaft is at its mid travel before inserting into the main assy.

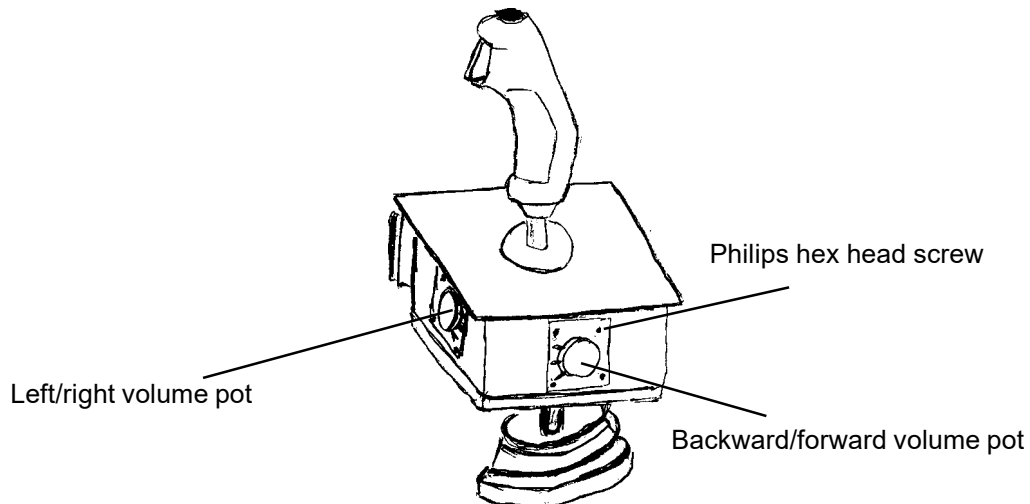

7-3-3 Removing the Grip

1. Remove the four security screws (M5x8) from either side and the philips head screw (M4x25) and nut.
2. The microswitches are fitted to the same side as then nut.
3. Ensure that the springs are fitted correctly and that no wires are trapped when re-assembling.

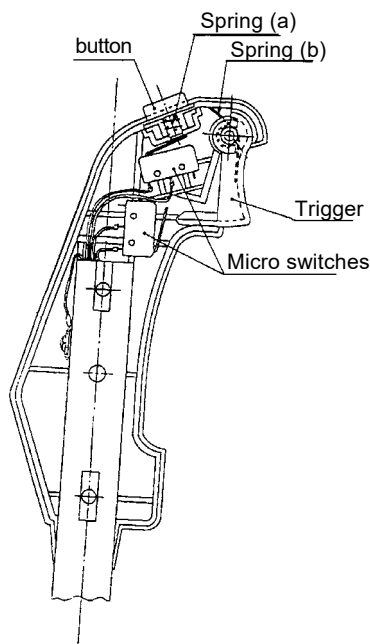

7-4 Removing the Control Panel Assy

1. Remove the rear cover (B) located on the back of the main body.
2. Disconnect all connectors to the control panel assy.
3. Remove the four assembling bolts (M10 X 45).
4. Lift the control panel assy, unhook and pull the control panel assy forwards to remove it from the main body.

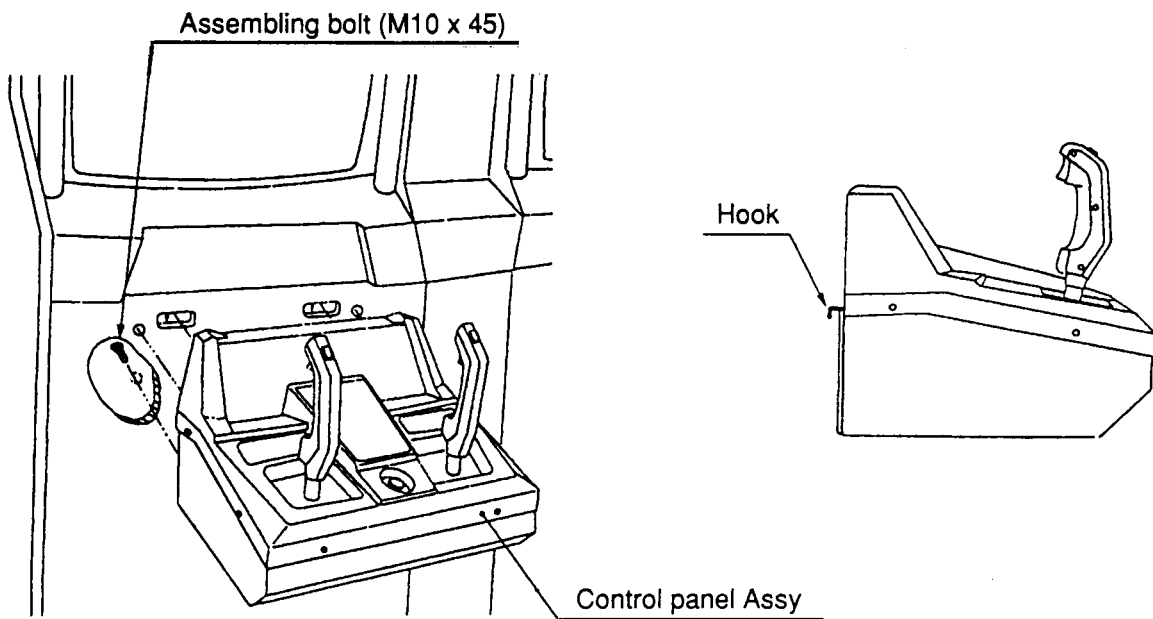

7-5 Removing the Monitor Bezel

1. Remove the rear cover (B) located on the back of the main body.
2. Loosen the four assembling bolts (M10 X 45) fixing the control panel assy. (Do not remove them).
3. Remove the four torque bolts (M5 x 20).
4. Lift the monitor bezel upwards and forward to remove it.

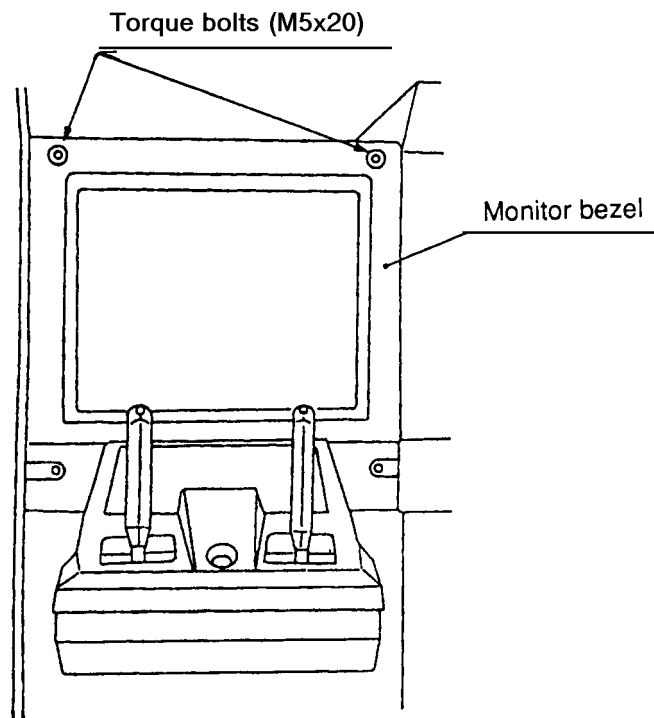

8 Illustrated Parts List

8-1 Main Body Assy

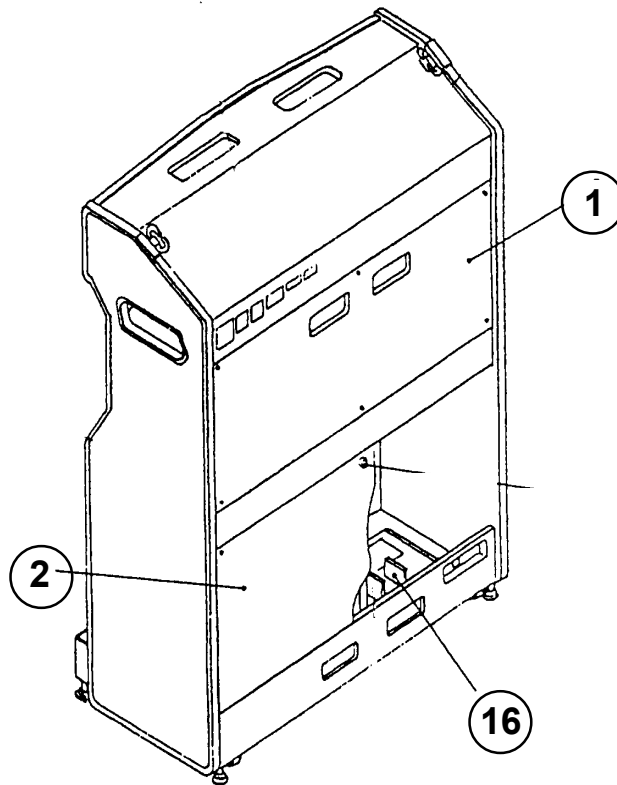
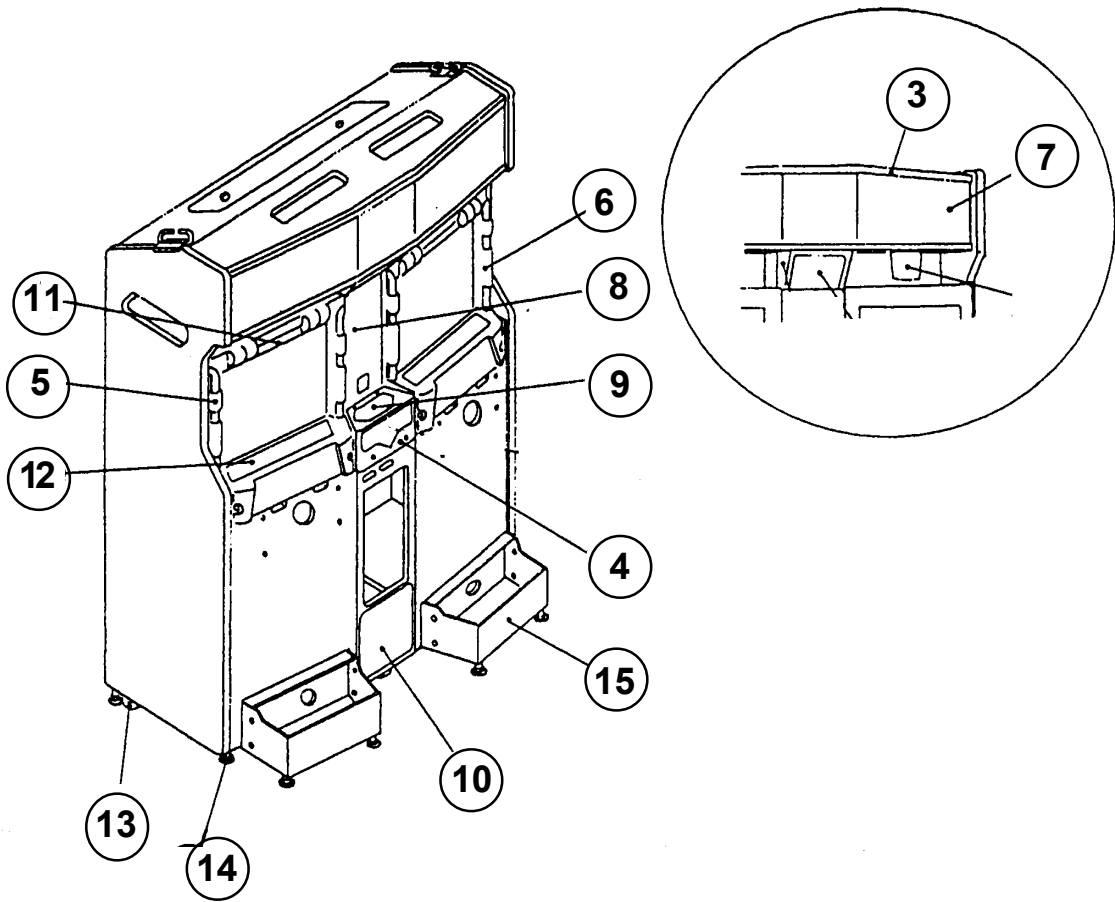

As these environmental factors limit the functions of the radar, the game becomes more difficult to play.

No	Description	Qty	Part Number
1	Rear Cover (A)	1	n/a
2	Rear Cover (B)	1	n/a
3	Top Flash Bracket	2	88300610
4	Front Cover	1	88300612
5	Monitor Vac Form - Blue	1	85300621
6	Monitor Vac Form - Red	1	85300622
7	Marquee Acrylic	1	30000002
8	Front Sticker (EX)	1	40000170
9	Front Sticker (B)	1	40000173
10	Lower Sticker	1	40000171
11	Monitor Sticker	1	40000175
12	Instructions Sticker (EX)	1	40000176
13	Castor	4	59000005
14	Adjuster	4	88300079
15	Base Floor Connector	2	88300616
16	Switching Regulator 5v 30A/12v 7A	1	83000004

8-2 Control Panel Assy

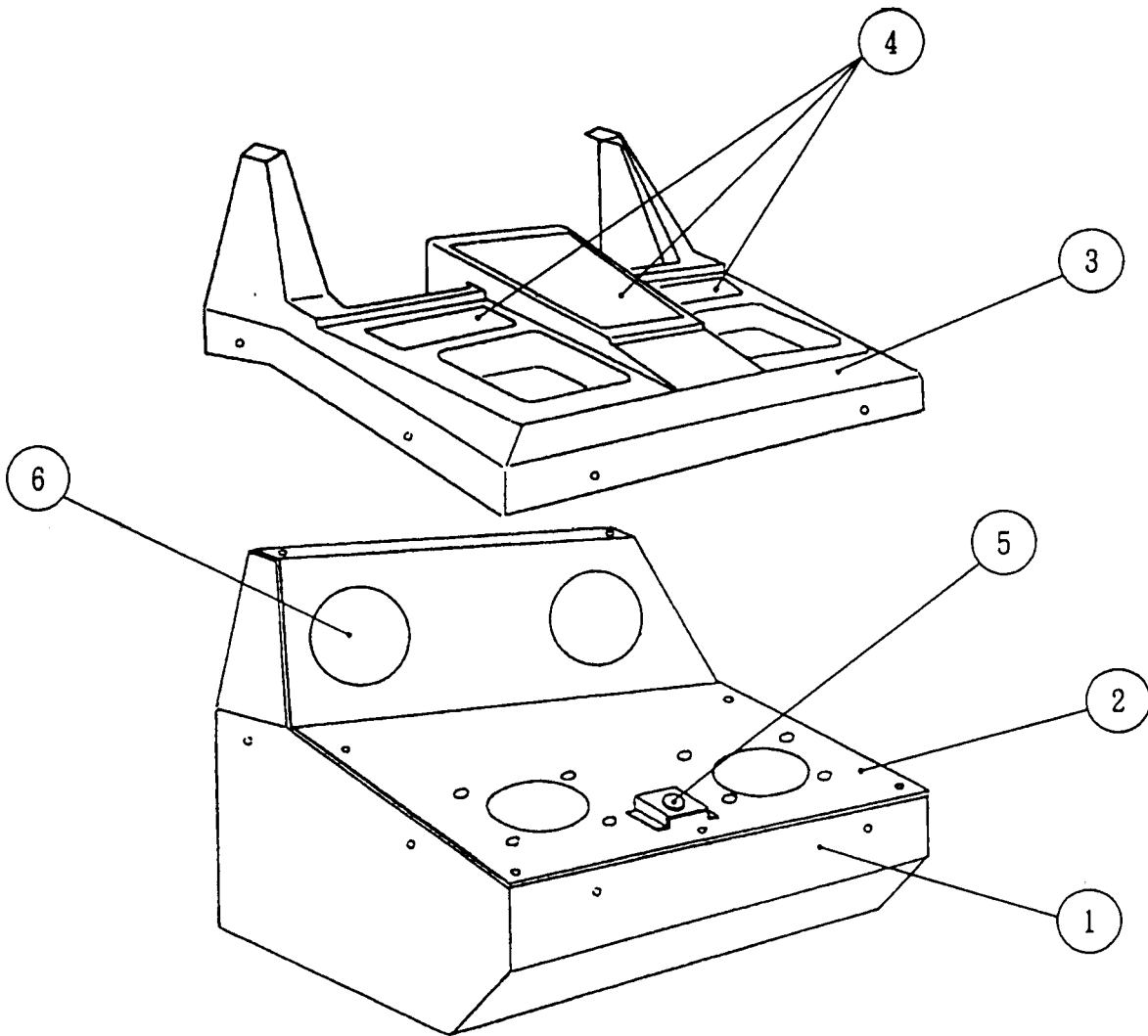

No	Description	Qty	Part Number
1	Control Panel Case	1	88300623
2	Control Panel Cover	1	88300624
3	Panel Cover (Blue)	1	88300625
	Panel Cover (Red)	1	88300626
4	Control Panel Sticker (LH)	1	40000177
	Control Panel Sticker (RH)	1	40000179
	Control Panel Sticker (Centre)	1	40000178
5	Push Switch	1	60500061
6	Speaker	1	62000007

8-3 Seat Assy

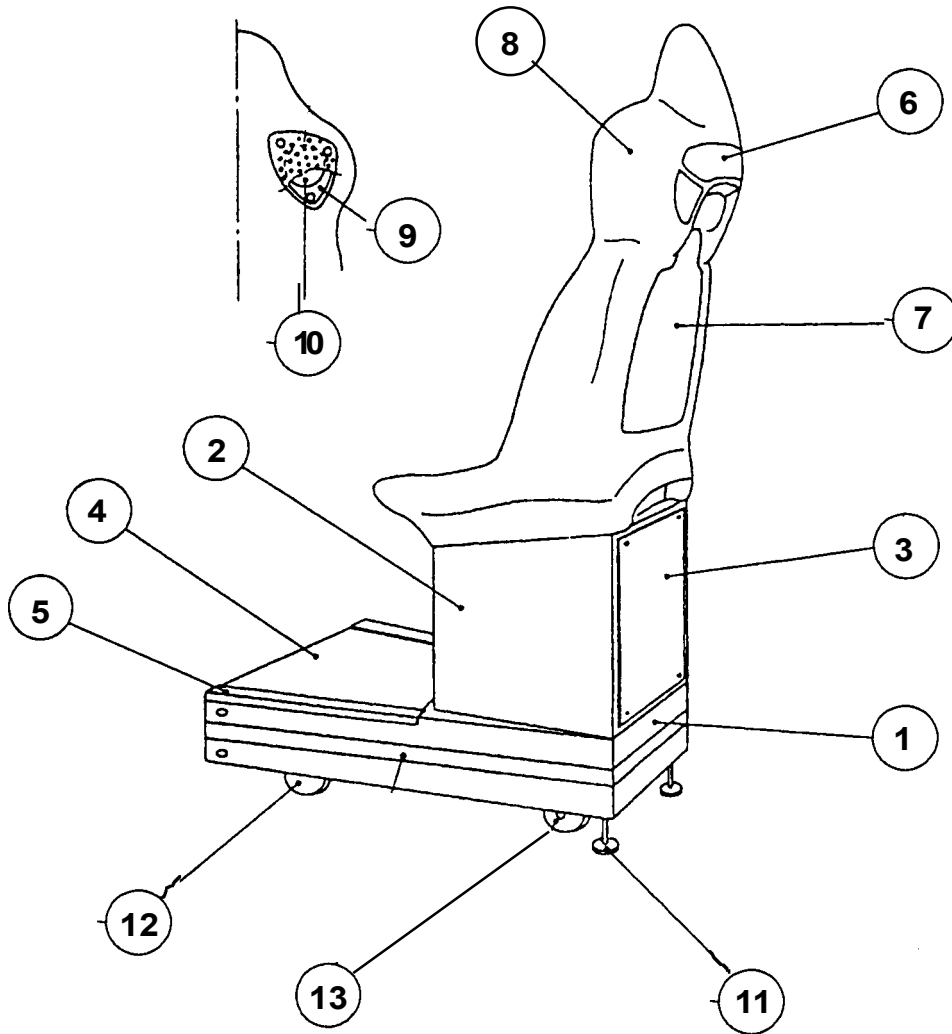

No	Description	Qty	Part Number
1	Base floor	1	88300605
2	Seat base	1	88300606
3	Seat base cover	1	88300607
4	Floor mat	1	88300609
5	Edge trim	2	88300608
6	Back sticker	1	40000180
7	Seat sticker (blue)	1	40000168
	Seat sticker (red)	1	40000169

No	Description	Qty	Part Number
8	Seat Blue (Left)	1	88300601
	Seat Red (Right)	1	88300602
9	Speaker plate	2	88300603
10	Speaker	2	62000007
11	Adjuster	2	88300079
12	Castor	2	59000005

8-4 Lever Assy

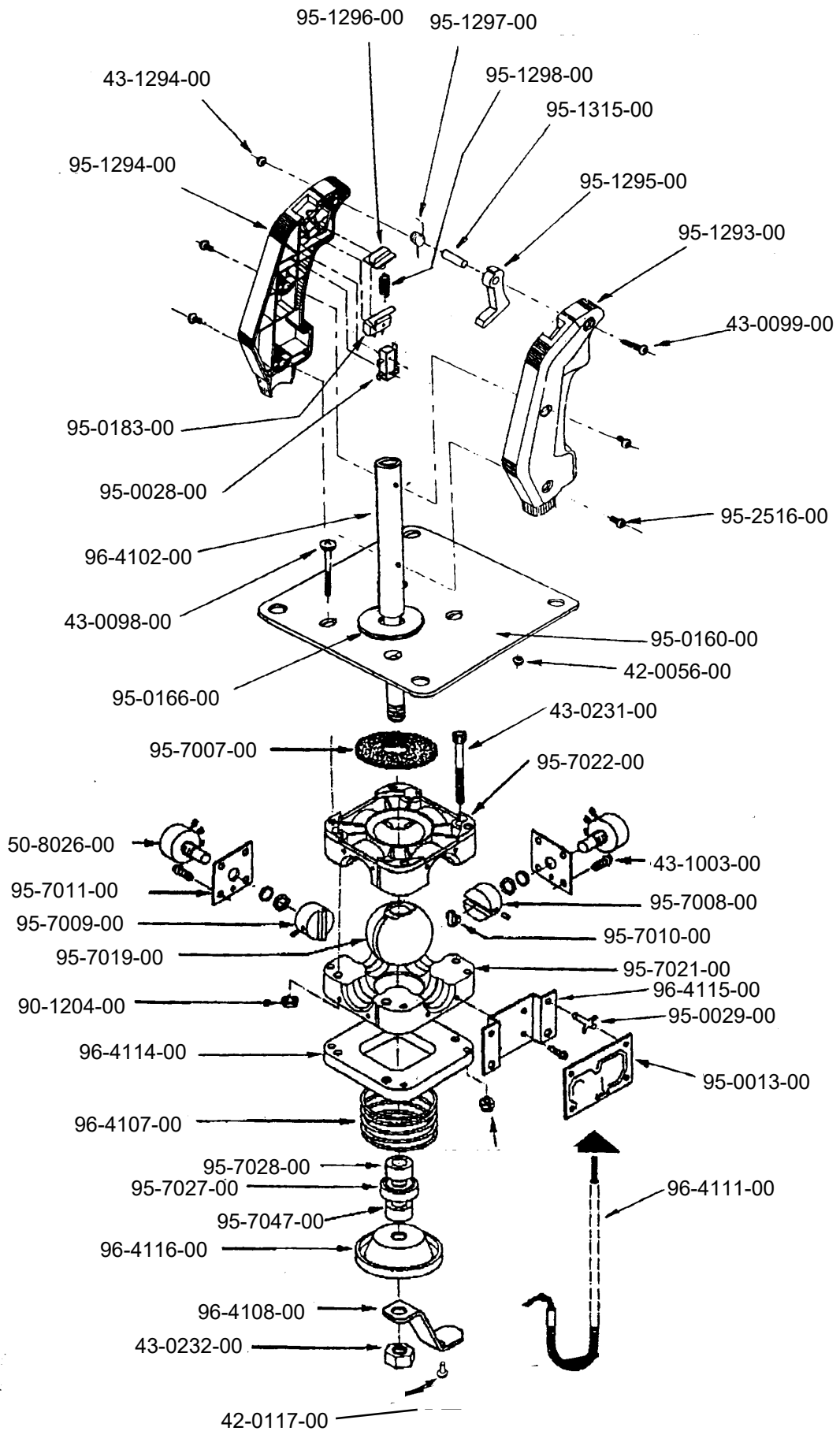

9. Troubleshooting

If you suspect the game may be malfunctioning, the following steps should be considered before you make a service request.

1. When some other equipment (air conditioners, multiple pinball games, large Kiddie Rides) are connected to the same power supply, the voltage may fluctuate and cause this game trouble or improper operation.
 2. When the game PCB, the ROMS, the lever assembly or volume controls are replaced, it is necessary to make adjustment for the game to function normally. Make appropriate adjustments referring to section "5-5 Replacement Parts Adjustment".
 3. Check all connectors as malfunctions can be caused by loose connections.
 4. Dust or foreign substances on the PCB's may cause malfunctions or improper operation. Check the PCB's are clean.
 5. Use the wiring diagram for reference, when you make electrical checks. Check the wiring diagram to make sure of the connection of electric parts, the connector number, the colour of the wire, and so on.
- Contact your distributor if the above suggestions are not applicable or no improvement is observed.
 - Return the Printed Circuit Board (PCB) to your distributor for any repairs. Do not use a multi-meter on the PCB. This PCB contains sensitive chips which could be destroyed even by the internal voltage of the multi-meter.
 - When sending parts to be repaired, make sure they are packed securely with a complete explanation of the problem. When sending PCB's, package them in anti static foam or bubble wrap, and pack them in cardboard boxes to protect against impact damage.

namco[®]

BRENT LEISURE Ltd.
Unit 1 Brent Crescent,
London. NW10 0QT

Phone: 081- 965 - 0550
Fax: 081 - 961 - 0574